

# Garden Park

## Community Wildfire Protection Plan



## Signatory Page

The following people have reviewed and approved the Garden Park Community Wildfire Plan. It is now ready for implementation.

_____, President, Board of Directors, Dilley Park Home Owners Association	_____ Date
_____, President, Board of Directors, Cooper Mountain Home Owners Association	_____ Date
_____, President, Board of Directors, Canon City Fire Protection District	_____ Date
_____, Sheriff, Fremont County	_____ Date
_____, Chair, Fremont County BOCC	_____ Date
Steve Morrissey, Director, Fremont County Office of emergency Management	_____ Date
Keith E. Berger, Field Manager, USDI BLM Royal Gorge Field Office	_____ Date
Joan Adair, President, Fremont Conservation District	_____ Date
John Grieve, State District Forester, Canon City, Colorado State Forest Service	_____ Date

# TABLE of CONTENTS

Signatory Page.....	2
TABLE of CONTENTS.....	3
PREFACE:.....	5
I. COMMUNITY IDENTIFICATION & DESCRIPTION .....	6
Table 1: Garden Park Land Ownership, Structures & Lots .....	7
Figure 1: Garden Park Vicinity Map .....	8
II. COMMUNITY ASSESSMENT .....	9
Fuel Hazards .....	9
Table 2: Garden Park Vegetation .....	9
Fuel Models .....	10
Table 3: Fuel Models and Vegetative Types in Garden Park .....	10
Table 4: Garden Park Fire Behavior Prediction .....	13
Chart 1: Flame Lengths on Garden Park .....	14
Figure 2: Fuel Model Map .....	15
Table 5: Fire Hazard Based On Rate of Spread & Resistance to Control .....	16
Risk of Ignition and Wildfire Occurrence .....	16
Community Values at Risk & Hazard Assessment .....	17
Values: .....	17
Access: .....	17
Risk:.....	18
Triage:.....	18
Table 6: Structure Triage by Subdivision. ....	19
Evacuation:.....	19
Local Preparedness and Protection Capability .....	20
Table 7: CC FPD Wildland Fire Suppression Resources.....	20
Water Supply:.....	21
Grazing:.....	21
III. COMMUNITY MITIGATION PLAN.....	22
Survivable Space: .....	22
Home Ignition Zone .....	22
Chart 2: Slope Impact on Survivable Space .....	24
State Tax Incentives for Wildfire Hazard Mitigation: .....	24
Education and Information: .....	25
Fuel Hazard Reduction:.....	25
Table 8: Garden Park Potential Shaded Fuelbreaks .....	27
Fuelbreak Maintenance:.....	27
Treatment Costs:.....	27
Wildfire Suppression Infrastructure: .....	27
Turnarounds:.....	27
Fire Control Features/Triage Maps:.....	28
Uniform Street Addresses: .....	28
Improving Water Supply for Wildfire Purposes: .....	28

Evacuation Planning:.....	30
Evacuation Option: .....	31
Strategic Recommendations: .....	31
Fire Protection Situation:.....	31
Table 9: Comparison of Options to Enhance Fire Protection District Coverage .....	32
IV. IMPLEMENTATION & MONITORING .....	32
Implementation: .....	32
Table 10: Implementation Items Priority & Cost .....	33
Monitoring: .....	33
Table 11: Action Plan for Completing the Garden Park CWPP .....	34

**Appendices:**

**A** – General Maps

**B** – Triage and Fire Control Features Map

**C** – Evacuation Planning

**D** – Structure Triage

**E** – FireWise

**F** – Fuelbreak Guidelines

**G** – Fuelbreaks & Prescribed Burns

**H** – Road & Driveway Specifications

**I** – Definition of Terms

**J** – Potential Sources of Funding

**K** – References & Publications

## PREFACE:

A Community Wildfire Protection Plan (CWPP) is a local wildfire protection plan that can take a variety of forms based on the needs of the community. The CWPP may address issues such as wildfire response, hazard mitigation, community preparedness, training, equipment or structure protection – or all of the above.

The process of developing a CWPP can help a community clarify and refine its priorities for protection of life, property and critical infrastructure in the wildland-urban interface. It also can lead community members through valuable discussions regarding management options and implications for the surrounding watershed.

This CWPP incorporates the “Fire Adapted Communities Concept” by including projects that support resilient landscapes and addressing the community response to wildfires.

CWPPs also improve a community’s ability to compete for grants to fund hazard mitigation projects, prevention, and preparedness education for residents in the community.

The wildland urban interface (WUI) is another term found throughout this document. It can be simply described as the geographical area where structures and other human development meet or intermingle with wildland or vegetative fuels. For the purposes of community wildfire protection planning a more specific definition is used. The Healthy Forest Restoration Act defines wildland-urban interface as:

- a.) an area extending ½ mile from the boundary of an at risk community.
- b.) an area within 1.5 miles of the boundary of an at risk community, including any land that:
  1. Has a sustained, steep slope that creates the potential for wildfire behavior endangering the at risk community.
  2. Has a geographic feature that aids in creating an effective fire break, such as a road or ridge top.
- c.) An area that is adjacent to an evacuation route for an at risk community that requires hazardous fuels reduction to provide safer evacuation from the at risk community.

## I. COMMUNITY IDENTIFICATION & DESCRIPTION

The Garden Park (GP) community area is in Fremont County, north of Canon City, Colorado. It covers approximately 37,319 acres and ranges in elevation from 5,600' to 9,100 feet at the top of Cooper Mountain. Garden Park Road, provides primary access to area. See **Figure 1: Garden Park Vicinity Map** for a comprehensive understanding of the park location. See **Table 1: Garden Park Land Ownership, Structures & Lots** to get an idea of land ownership and structure distribution.

GP contains four subdivisions containing 65 lots. There are another 74 parcels of private land. Approximately two new homes are being built each year in GP. Twenty (21) miles of public roads and five miles of private roads serve the area. Most roads are reasonably good dirt and gravel that provide year round access.

Two home owners associations are active in Garden Park. Defensible space activities are evident. Evacuation planning has not been done.

Previous fires in the area have created a vegetative tapestry of pinyon, juniper, grasslands, Gamble's oak, and mountain mahogany. This vegetative blanket lays on a highly dissected series of ridges, draws and canyons. Slopes range from ten to fifty percent with an average approximating 15 percent.

Large wildfires are not unusual in the area. The Dinosaur fire burned 2,400 acres in 1988 on the south eastern side of the Garden Park area. The Royal Gorge fire of 2013 burned 3,218 acres and destroyed forty eight structures in similar fuel types and terrain as found in Garden Park. The Parkdale fire of 2010 burned 629 acres and destroyed five structures. These fires increased Garden Park resident's awareness of the hazards of living in a wildland setting.

Initial attack for all wildland and structure fires on Garden Park is provided by the Canon City Fire Protection District, Fremont County Wildland Fire Team, Bureau of Land Management and US Forest Service.

A public meeting was held on September 26, 2013 to review the draft Community Wildfire Protection Plan (CWPP) and incorporate changes suggested by the property owners, fire district representatives, Colorado State Forest Service (CSFS) personnel and Fremont County Sheriff's Department. Twenty five residents participated in the meeting and their comments have been included in this plan.

Table 1: Garden Park Land Ownership, Structures & Lots

Name	Acres	# of Triaged Structures	# of Lots
<b>Cliffside Heights</b>	374	8	10
<b>Cooper Mountain</b>	631	22	18
<b>Dilley Ranch North</b>	1061	39	27
<b>Dilley Ranch South</b>	319	7	10
<b>Other Private Areas</b>	10321	72	74
<b>Bureau of Land Management</b>	23308	0	0
<b>State Land Board</b>	1304	0	0
<b>TOTAL</b>	<b>37319</b>	<b>148</b>	<b>139</b>

Figure 1: Garden Park Vicinity Map





## II. COMMUNITY ASSESSMENT

The overall risk to the community from wildland fire is MODERATE. This section will discuss the factors considered and contributing to the overall rating.

### *Fuel Hazards*

Dense stands of conifer, brush and grasslands cover the area. See **Table 2: Garden Park Vegetation** for a thorough list of vegetation found within the CWPP boundary. In an ongoing effort to mitigate wildfire hazard near homes, approximately 790 acres of pinyon/juniper have been hydro axed and 148 acres have been treated by hand. This work has been funded and accomplished by individual landowners working in cooperation with the Fremont Conservation District, NRCS, Colorado Habitat Partnership Program, Colorado State Forest Service and the Bureau of Land Management.

**Table 2: Garden Park Vegetation**

<b>Vegetation</b>	<b>Acres</b>
Ag Land	262
Aspen	299
Aspen-Mixed Conifer	1393
Barren	37
Developed	370
Grass	2223
Mixed Conifer	12481
Oak Shrub land	483
Pinyon-Juniper	13926
Ponderosa pine	3103
Riparian	1160
Sage	615
Shrub land	874
Spruce-fir	14
Water	27

All forest stands adjacent to structures with crown closures greater than forty percent are problematic. Continuous surface and crown fuel arrangement, both horizontal and vertical, render this area susceptible to torching, crown fire, and ignition by wind born embers, even under moderate weather conditions. The following Fire Hazard & Mitigation Map shows the severity of fire hazard for Garden Park with fully eighty three percent (83%) rated as moderate to severe fire hazard.

Local topography further aggravates fire behavior and control. Slopes range from ten to fifty percent with most hillsides ranging from twenty to thirty percent.

### *Fuel Models*

Fuel models are a means of describing a wide variety of combustible conditions found in a wildland environment. Fuel size class, fuel loading in tons/acre, fuel bed depth, and fuel continuity across a landscape are all factors that are considered when assigning a fuel model to a specific tract of land. Since it is unrealistic to expect a few fuel model descriptions to represent the wide continuum of fuel beds found in the wild, fuel models are often combined by the percentage of an area they cover. Fire Behavior Fuel Models 1, 2, 4, 5, 6, 8, 9, 10 (Anderson 1982) plus some masticated and hand felled/lopped pinyon/juniper can all be found in GP. They provide the basic foundation for fire behavior calculations. **Table 3: Fuel Models and Vegetative Types Found Adjacent to Structures in Garden Park**, concisely describes fuel models in the GP area.

Masticated and hand felled and lopped fuels are also present in close proximity to structures.

**Table 3: Fuel Models and Vegetative Types in Garden Park**

Fuel Model*	Vegetation Type	Description	Acres	% of GP
1	Grass	Short, sparse, dry climate grass	3,193	9
2	Pine Shrub	Open pine stands with shrub understory	3,320	9
4	Mature shrub	High load, dry climate shrub 4-6 feet tall.	20	<1
5	Light shrub	A mix of oak and pinyon/juniper	12,909	35
6	Moderate shrub	Pinyon/juniper with some sage or other shrub	667	2
8	Pinyon/juniper	Closed canopy stands with short-needle conifers support fire in the compact litter layer.	7,753	21
9	Ponderosa pine & aspen	Long needle conifers or freshly fallen aspen leaves.	732	2
10	Mixed conifer	Mix of ponderosa pine, Douglas fir, white fir	8,203	22
Masticated	Pinyon/Juniper	Open canopy stands that have splintered woody fuel on the ground.	790	2
Hand Felled & Lopped	Pinyon/Juniper	Open canopy stands that have dead woody debris as a ground fuel.	148	<1

Here are a few representative photos of fuel models found on Garden Park.



Fuel Model 1



Fuel Model 8



Fuel Model 2



Fuel Model 5



Fuel Model 4



Fuel Model 10



Hand felled & lopped



Masticated

Some landowners have reduced ladder fuels adjacent to their structures by pruning the lower limbs off of trees. This reduces the likelihood of a ground fire becoming a crown fire. Pruned limbs must be disposed of and not left on the ground.

Table 4: Garden Park Fire Behavior Prediction

Fuel Model*	Rate of Spread (miles/hr.)	Flame length (feet)	1 hour fire size (acres)	1 hour Fire perimeter (miles)	Safety Zone Size (acres)
FM-1	0.8	4	202	2.1	0.09
FM-2	0.4	7	50	1	0.15
FM-4	0.7	18	150	1.8	0.60
FM-5	0.2	6	15	0.6	0.12
FM-6	0.4	7	47	1	0.15
FM-8	0.02	1	0.2	0.06	0.04
FM-9	0.1	3	3	1.24	0.07
FM-10	0.1	5	2	0.21	0.11
Masticated	0.01	1	0.1	0.03	0.04
Hand felled & Lopped	0.08	4	1.8	0.2	0.08

Note: Shaded zones are well beyond hand crew and engine suppression threshold.

Fire behavior predictions are based on the 90<sup>th</sup> percentile weather conditions from 4 Mile remote automated weather station (RAWS) #53903. This RAWS sits at 6,310 feet elevation and is within the Garden Park CWPP analysis area. Fire behavior inputs include: Temperature of 94°F, Relative humidity = 7%, Twenty foot wind speed = 10 mph, and fuel moistures of: 1,000 hr. = 8%, 100 hr. = 6%, 10 hr. = 3% & 1 hr. = 2%.

Spot fires will likely ignite up to a half mile from the flaming front. Crown fires are likely to spread at 0.34 miles per hour.

Doubling the wind speed more than doubles most of the above fire behavior.

Chart 1: Flame Lengths on Garden Park

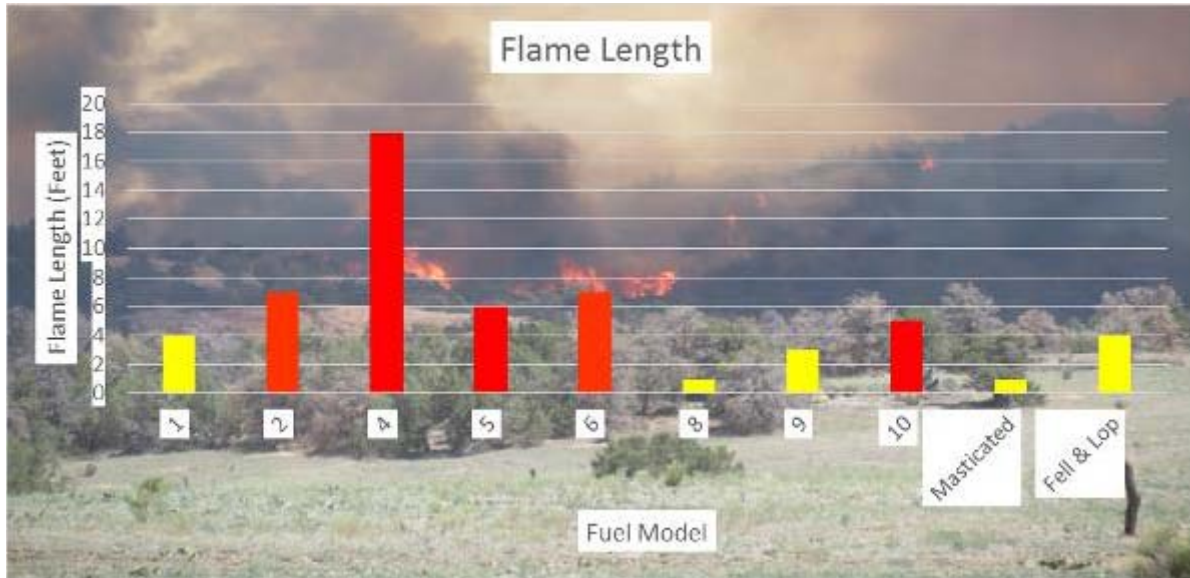

Figure 2: Fuel Model Map

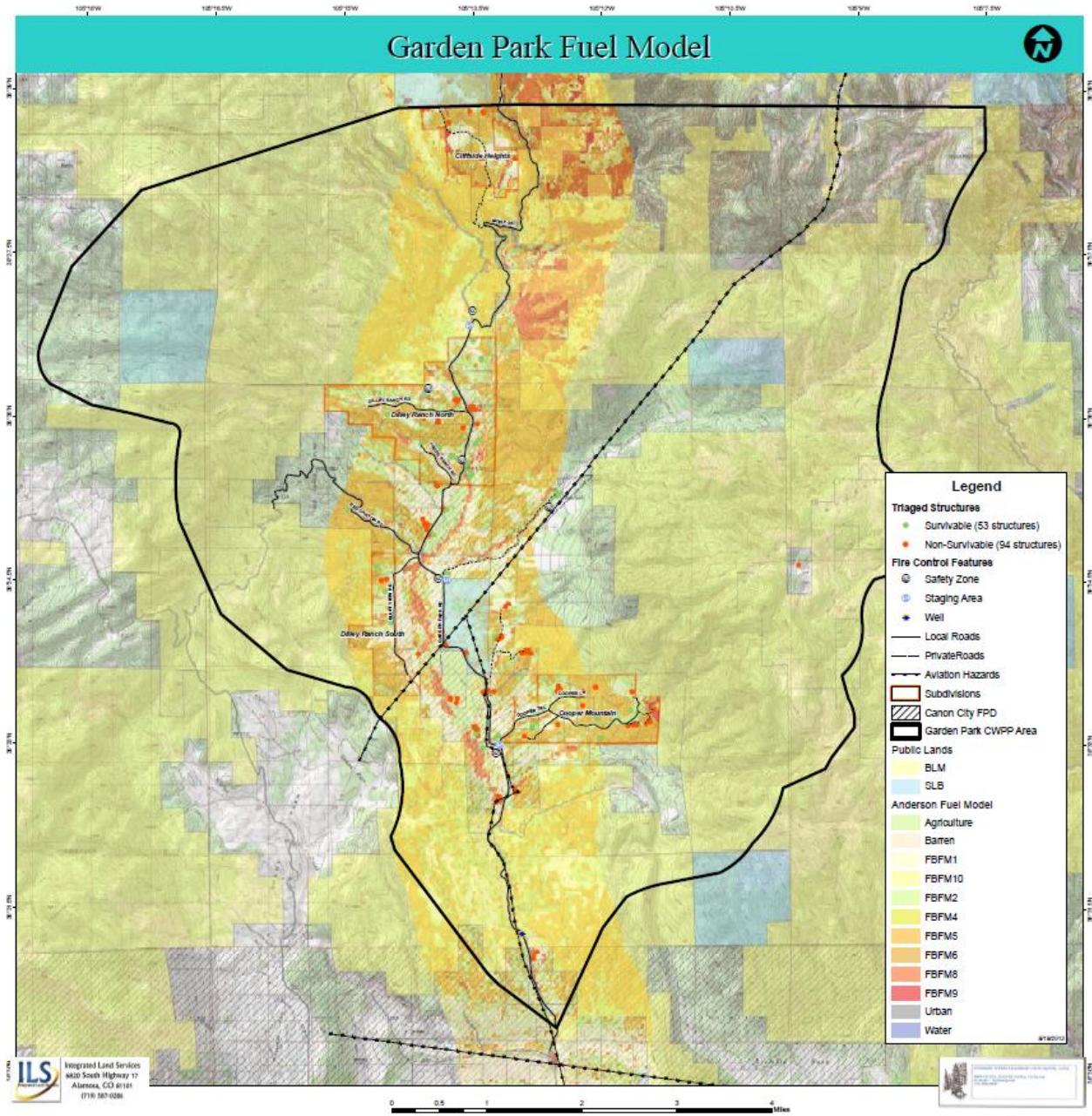

Table 5: Fire Hazard Based On Rate of Spread & Resistance to Control

Fuel Model	ROS	RTC	Hazard	% of Area
1	High	Low	Moderate	9
2	Moderate	Moderate	Moderate	9
4	High	High	High	<1
5	Low	Moderate	Moderate	35
6	Moderate	High	High	2
8	Low	Low	Low	21
9	Low	Moderate	Moderate	2
10	Low	Moderate	Moderate	22
Mastication	Low	Moderate	Moderate	2
Fell & Lop	Low	Moderate	Moderate	<1

NOTE: ROS = Rate of Spread & RTC = Resistance to Control

### *Risk of Ignition and Wildfire Occurrence*

The robust vegetative mosaic found in Garden Park is living testimony to fires role in ecosystem dynamics in the area. Most contemporary fires are lightning caused but human caused fires are expected to increase as more homes are built in Garden Park.

Fremont County has experienced a number of large wildfires recently. The 3,218 acre Royal Gorge fire of 2013 started during the field work for this Community Wildfire Protection Plan. It burned forty eight structures.

Other fires in the vicinity provide a serious warning for all people living in places prone to wildland fires. They include Black Forest, Waldo, Wetmore, Mason, Iron Mountain and the list goes on.

Low fuel moistures and low relative humidity are common in the area, as are periods of high winds. When dry and windy conditions coincide the stage is set for large, troublesome wildfires.

Fires originating in or near the community are of most immediate concern, but fires starting well beyond the boundaries of the planning area can have profound effects upon the Park. Rapid rates of spread and long distance spotting (starting of new fire by windblown embers) are the norms for fires in the vicinity. **Table 4: Garden Park Fire Behavior Prediction** provides insight into potential fire behavior on a bad day at Garden Park.

Red Canyon Park and the Shelf Road Climbing Area provide developed picnic and camping facilities within the Garden park CWPP area. Individuals from all over come to picnic, camp, rock climb, mountain bike and hunt. This additional human activity increases the probability of human caused wildfires.



## ***Community Values at Risk & Hazard Assessment***

### **Values:**

One hundred forty eight (148) structures were triaged based on their anticipated ability to survive a wildfire in their vicinity without any human intervention to prevent them from burning at the time of the fire. Thirty six percent (36%) or fifty five buildings are expected to survive. Ninety eight (98) structures or 64% will likely be destroyed when there is a wildfire in the neighborhood. The structures range from substantial permanent residences to tuff sheds, travel trailers and metal sheds.

Garden Park landowners place a high premium on their natural surroundings and the visual quality of the landscape. Vast expanses of heavily burned, charred forest are objectionable whether structures burn or not. If the view is seriously eroded much of the intrinsic value of the home will also be lost.

A large, intense fire will also compromise watershed values and cause sediment and turbidity issues along Fourmile Creek and ephemeral streams. Most of the ponds in the area, which are impounded by earthen dams, will be filled with sediment compromising wildlife and livestock watering opportunities.

### **Access:**

Garden Park road runs through the middle of Garden Park and provides the only access out of the park in an emergency. The Shelf road runs north to Cripple Creek but is a very narrow, winding road with blind turns and few places where vehicles can pass each other safely. One mishap or mechanical problem during an evacuation could easily close the road, stranding anyone on the wrong side of the problem.

Twenty two miles of gravel and dirt roads provide reasonably good access throughout Garden Park. Addresses are sporadically displayed at driveway intersections with access roads. Several locked gates will impede first responders until they breach the barrier. Without an accurate map or detailed instructions it can be very difficult for first responders to find a specific address even though most intersections are signed.

Road grades seldom exceed 10 percent (10%) on main arterials in the community. Driveways can be as much as fifteen percent (15%). Dead end roads do not have "No Outlet" signs at the junction with the main road. Turnarounds and cul-de-sacs at the end of the roads are inadequate for large structure fire equipment.

## Risk:

Three kinds of risk are associated with wildland fire. The first concern is the risk to people trying to evacuate under less than optimal conditions. Second is the risk to firefighters attempting to protect property. Third is the risk wildfire poses to property. The concept of survivable space addresses both the second and third facets of risk under one umbrella.

Survivable space is an area around the structures where fuels and vegetation are treated, cleared or reduced to slow the spread of wildfire towards the structure and lower the intensity of the fire as it passes the developed area. It also reduces the chances of structure fire moving from the building to surrounding vegetation. Survivable space provides room for firefighters to do their jobs. A house is likely to withstand a wildfire if vegetation is managed to reduce a fire's intensity. Structure design and construction also influence its survivability when a wildfire passes through the neighborhood. Removing flammable materials such as fire wood, lumber and gasoline from the decks and base of structures will pay big dividends when the ember storm hits the home.

The concept of “defensible” space assumes that there will be sufficient wildfire personnel and equipment to actively protect each threatened structure. This assumption is accurate when only one or two structures are imperiled. When numerous structures are threatened there aren't enough firefighting resources available in Fremont County to protect them all. Mutual aid assistance from other fire departments in the region take time to mobilize and take effective action during large incidents.

Survivable space around a structure is the key to assuring that a home is still standing after a major wildfire. A structure is survivable **IF** it can withstand being overrun by a high intensity wildfire without any on site intervention by wildfire personnel. It requires close attention to structure design, construction, and its relationship to combustible natural and anthropocentric materials.

## Triage:

Structure triage was conducted on each parcel with buildings on it. Triage is a concise decision making process that is used if/when a wildfire threatens multiple structures simultaneously. See **Appendix D: Structure Triage** for a brief description of the triage process. The following observations are gleaned from the site visits.

- ✓ 36% of the structures were expected to survive. That leaves sixty four percent (64%) of the structures within Garden Park as likely to be destroyed or heavily damaged during a wildfire.
- ✓ Poor conditions in the structure ignition zone were the most prevalent problem found during triage. See the Discussion of the structure ignition zone starting on page 23.

It is important to understand the role of triage in this community wildfire protection plan. It is a quick, inexpensive way to determine overall community wildfire risk and helps to identify areas to focus improvement efforts. Its utility during an actual wildfire depends upon the nature of the

wildfire. When only one structure is threatened, firefighting resources are usually assigned to protect that single structure, unless it is a death trap and totally undefendable.

During a large wildfire scenario when more structures are threatened than there are firefighting resources to protect them, this triage work will help the Incident Commander assign scarce resources to the places where they have the best chance for success.

Maps developed for this Community Wildfire Protection Plan identify structure location and survivability. The CWPP is an ever evolving document and will be revised on a regular basis to reflect new information about structure survivability and other important fire control features in Garden Park.

**Table 6: Structure Triage by Subdivision.**

Subdivision	Acres	# Structures Triage	% Survivable	% Non-Survivable
Cliffside Heights	374	8	0	100
Cooper Mountain	631	22	32	68
Dilley Ranch North	1,061	39	49	51
Dilley Ranch South	319	7	71	29
Other Private Areas	10,321	72	32	68

**Evacuation:**

Garden Park only has one feasible evacuation route. It is County Road 9 also known as the Gold Belt road. The Shelf road to Cripple Creek is too narrow and serpentine to serve as a reliable evacuation route. One accident or stalled vehicle will easily close this road during an emergency.

Garden Park is blessed with several naturally occurring Safety Zones along County Road 9. They are large enough to hold numerous Garden Park residents and their animals. All but one of these potential Safety Zones are on private property. It is important to get approval from these landowners prior to designating Safety Zones on their property.

Notification of an impending evacuation has been problematic on several wildfires lately. Reverse 911 systems have had a difficult time keeping up with the wide array of communications options available to people today. People often convert from the traditional “land lines” to cellular phones without updating their contact information with emergency call centers.

See section III for a few additional thoughts to facilitate timely evacuation in a wildfire setting.

## Local Preparedness and Protection Capability

Canon City Fire Protection District (CCFPD) has two fire stations in Canon City. CCFPD has a cadre of twenty nine (29) paid full time personnel and twenty (20) volunteer firefighters. Thirty of them have been through basic wildland firefighter training. Sixty two percent (62%) of the structures covered by the Garden Park CWPP are within the fire protection district.

**Table 7: CC FPD Wildland Fire Suppression Resources**

TYPE RESOURCE	TYPE	# ON HAND	# DESIRED
<b>Canon City Fire Protection District</b>			
Personnel		6-9, + vols.	9-12, + vols.
Wildland firefighters (Carded)		30 total	30
Brush trucks 150-250 gallons	6	3	3
Squad truck 500 gal 500 gpm	3	1	2
Engine 500 gal 1000 gpm	1	2	3
Tender 3,000 gal 250 gpm		1	2@ 2000 gal.
Tender 1,000 gal 150gpm		1	*
Portable holding tanks	1500-2000 gal	2	2
Power saw kit (on Type 6 Engines)		3	--
Personnel & Equipment Transport		2	2
Wildland fire tool cache	20 person	1	2
<b>Fremont County Wildland Fire Team</b>			
Wildland firefighters (Carded)		12	
Engine - 250 gallons	6	1	
Engine - 300 gallons	6	1	
Engine - 500 gallons	6	1	
Tender - 1500 gallon 6x6		1	
Water trailer- 450 gallon		1	
Portable holding tanks		2	
<b>Colorado State Dept. Of Public Safety</b>			
Wildland Firefighters (Carded)		2	
Engine	6	1	
Power saw kit		2	
Wildland fire tool cache (20 person)	Mop up kits	1	
Bendix/King handheld radios		4	
Drip Torches		4	
<b>BLM/USFS Pike/San Isabel NF (1)</b>			
Wildland Firefighters (Carded)		26	
Engine	6	2	
Engine	4	1	
Power saw kit			
Portable pump kits	Mark 3	2	
Portable holding tanks	1500-2000 gal	3	
Wildland fire tool cache	100 person		

- (1) Structure protection is the responsibility of fire protection districts and state. Federal partners provide assistance upon request and are most likely to do more wildland type suppression work, hence there isn't a need for heavy structure protection apparatus or resources.

This compliment is at best 15 minutes from the entrance to Garden Park and as much as 45 minutes to the scene depending on the location in the Park. BLM & USFS have initial attack resources stationed in Canon City that can respond in similar timeframes if they are not already assigned to an active wildfire.

Additional reinforcements from CCFPD and additional equipment and mutual aid from nearby departments are at least an hour out with availability dependent upon workload at the time of the request.

The BLM has a Single Engine Air Tanker (SEAT) base at the Fremont County Airport. A SEAT is not always stationed there or may be obligated to another wildfire.

Only a portion of the private land in Garden Park is within the Canon City Fire Protection District. CCFPD will respond to fires outside their district boundary but only if they can do so without severely drawing down their in district initial attack capabilities.

### ***Water Supply:***

Very little water is available for wildfire suppression in Garden Park. Extra water for winter structure fires is non-existent. Some residents currently have their own wells or haul water. There is a cistern at the old school house and a hand dug well at George Embelton's. A spring on Roger Motz place may have potential to feed a cistern. Other Garden Park Residents may be willing to have a well drilled on their property to provide reliable water for use year round for structure fires and for wildland fires during dry periods.

Fourmile Creek is often adjacent to Garden Park Road but can be difficult to access for most fire apparatus. The volume of water is also questionable during drought periods or when the creek is frozen over in the winter. There are also several seasonal ponds in the park that are adjacent to roads. These ponds are shallow, often dry, and cannot be relied upon for wildfire suppression purposes.

All homes in the Cooper Mtn. development have 2,000 gallon cisterns. These cisterns obviously need to be kept full year long if feasible. Their locations need to be marked and mapped so firefighters can find them promptly.

### ***Grazing:***

Garden Park has several working ranches and horse ranchettes that keep grass fuels in check. Without the livestock to keep these fine fuels under control a significant effort will be required to

periodically keep the grasses and other fine fuels mowed throughout the growing season. This grazing activity also maintains the potential Safety Zones in Garden Park.

### III. COMMUNITY MITIGATION PLAN

#### *Survivable Space:*

Effective survivable space is the landowners' most reliable means of providing wildfire protection for their structures. This is especially true in Garden Park. Terrain, heavy fuels, and landownership patterns in GP make landscape level fuel modification difficult. This plan suggests a few shaded fuelbreaks along strategic ridges and roads and a prescribed burning initiative, but **the key to individual structure survival is Survivable Space and good "Fire Wise" practices immediately adjacent to structures.**

During periods of high to extreme fire danger a wildfire will rapidly exceed the suppression capability of the local fire suppression forces. **Table 4: Garden Park Fire Behavior Prediction** displays the difficult position firefighters will face on a dry, windy day. Hand crews are effective when flame lengths are less than four feet. On a bad day only thirty two percent (32%) of Garden Park is expected to have fire of this intensity. The remaining sixty eight percent (68%) of the area will experience flame lengths from four to eighteen feet. The size of a fire within the first hour is also expected to grow beyond local initial attack capability over twenty one percent (21%) of the Park.

Homeowners should not expect much protection intervention if/when a large fire burns through the Park. The harsh realities of triage and coordinating attack with mutual aid forces will consume local fire forces for several hours. ***Fire Wise rated survivable space is the key to structures surviving on their own. Do it now and maintain it.***

In many cases, sizeable effort has been spent developing defensible space around quality homes perched on the edge of a steep slope with heavy vegetation below the structure. Unfortunately the trajectory of the flames will intersect the structure, exposing it to direct contact with flames. The County will encourage people to set new homes back from the edge of steep, brushy slopes using the guidelines provided in "Protecting Your Home from Wildfire - Creating Wildfire Defensible Space Zones", Quick Guide Series Fire 2012-1 available on the CSFS website and included in this CWPP as Appendix L.

#### Home Ignition Zone

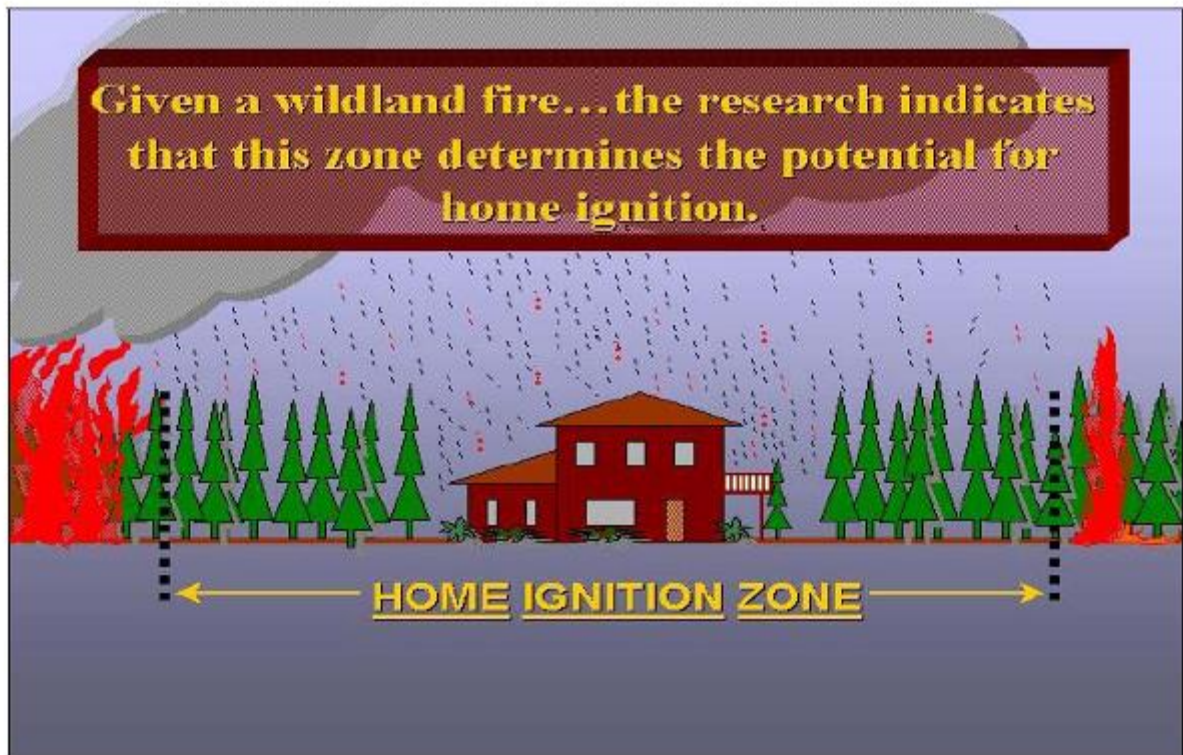

*A home with its immediate surroundings (about 100-150 feet from the structure) is the home ignition zone.*

Recent research into the cause for loss of homes during wildfires indicates that home ignitability, rather than wildland fuels, is the principal cause of home losses during wildland/urban interface fires. Key items are flammable roofing materials (e.g. cedar shingles) and the presence of burnable vegetation (e.g. ornamental trees, shrubs, wood piles, and pine needle accumulation) immediately adjacent to homes (Cohen, 1999).

The home ignition zone includes a home and its immediate surroundings within 100 to 150 feet of the structure. Fuel conditions within this zone, to a large degree, will determine whether a home will survive a wildfire. High intensity fire behavior beyond the home ignition zone does not transfer enough energy directly from its flames to ignite a wooden structure. The fuels surrounding a home within the home ignition zone principally determine the potential for directly igniting the home. Firebrands lofted from extreme wildfires must directly ignite on a structure to be an effective ignition source. If firebrand ignitions occur in the fuels surrounding a home, then those fuels determine the home's ignition potential. Thus, regardless from how far firebrands travel a home's exterior materials and design and fuels in the home ignition zone determine its ignition potential from firebrands.

The primary and ultimate responsibility for home wildfire protection lies with private homeowners, not public land management agencies (or taxpayers). It is critical that special attention be given to removing fuels in the home ignition zone around structures to improve their chances of surviving a wildfire. This includes insuring that there are no combustible materials like concentrations of pine needles, dry grass, hay or straw, firewood, deck furniture, household trash, flammable materials such as gasoline, diesel or paint thinners, paper boxes, and fabrics near the structure or in the home ignition zone for firebrands to land on. In the past few years research has found that a significant number of homes destroyed in wildfires burned as the result of the presence of combustible materials within the home improvement zone. Some homes ignited as much as 8 hours after the fire front passed. Reducing places for embers to penetrate the home such as open windows and vents also improves structure survivability.

**Chart 2: Slope Impact on Survivable Space**

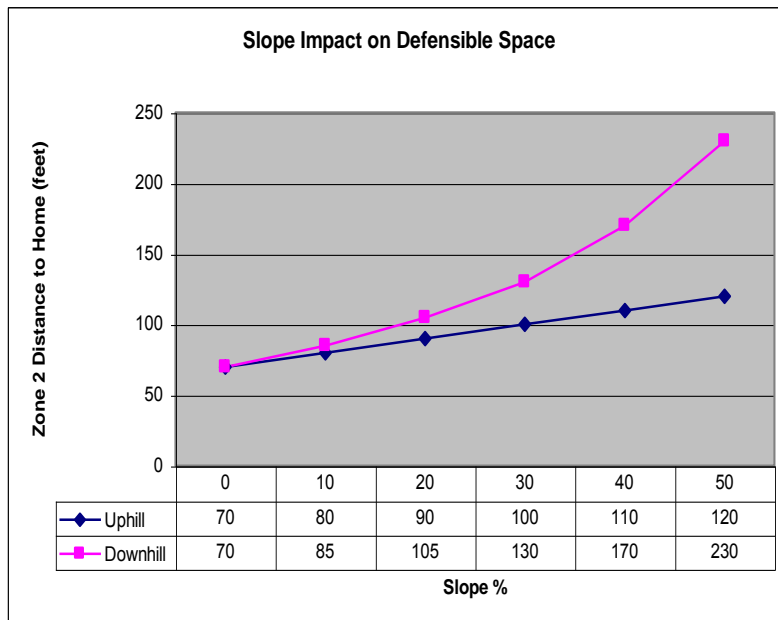

This chart indicates how far thinning needs to be done above and below a structure based on the slope it is on or adjacent to. It is also a good source to determine how far back from a slope to set a new structure

*Colorado State Forest Service in Canon City maintains a list of local contractors that do wildfire hazard reduction work. They can be reached at 719 275-6865 for current listing.*

**State Tax Incentives for Wildfire Hazard Mitigation:**

House Bill 1110 created a five year program from 2009 to 2014 that allows landowners to deduct the actual costs of their wildfire mitigation, up to \$2,500 from their taxable income. The program allows each landowner to get credit for fifty percent of the cost of wildfire mitigation up to a total of



\$2,500. To get the full credit the total mitigation costs must be \$5,000 or greater. The work must be done in accord with an existing Community Wildfire Protection Plan to qualify. On April 4, 2013 the Governor signed House Bill 13-1012 that extend the deduction until January 1, 2025 to encourage more residents of the Wildland Urban Interface to mitigate wildfire hazards around their homes.

This is a good incentive for individual landowners to improve survivable space around their structures.

### ***Education and Information:***

Dollar for dollar, one of the best ways to improve community wildfire resilience is wildfire awareness activities such as brochures, public service announcements, workshops and informal discussions in the neighborhood. Fremont County has a FireWise trailer that they take to various gatherings in the County. It contains materials and displays that speak to the benefits of FireWise behavior. The trailer is available for Property and Home owners associations to use for member information exchanges. The Royal Gorge fire provides a reminder and “teachable moment” to focus Garden Park landowners on the realities of the environment in which they live.

### ***Fuel Hazard Reduction:***



Individual owners have done varying degrees of wildfire mitigation work around their structures and along their driveways. More work is needed to mitigate wildfire hazards within Garden Park.

This photo provides a good example of a shaded fuelbreak created using a Hydro-ax to masticate pinyon and juniper trees. This treatment reduces crown fire potential and can provide a safer place for firefighters to construct fireline.

Pruning low level limbs from trees reduces ladder fuels that contribute to crown fire spread and intensity.

Garden Park Potential Shaded Fuelbreaks and the Recommended Landscape Scale Fuel Treatment Map and Table 8: Garden Park Potential Shaded Fuelbreaks provide the detail for the recommended fuel treatments.

# Recommended Landscape Scale Fuel Treatment Map:

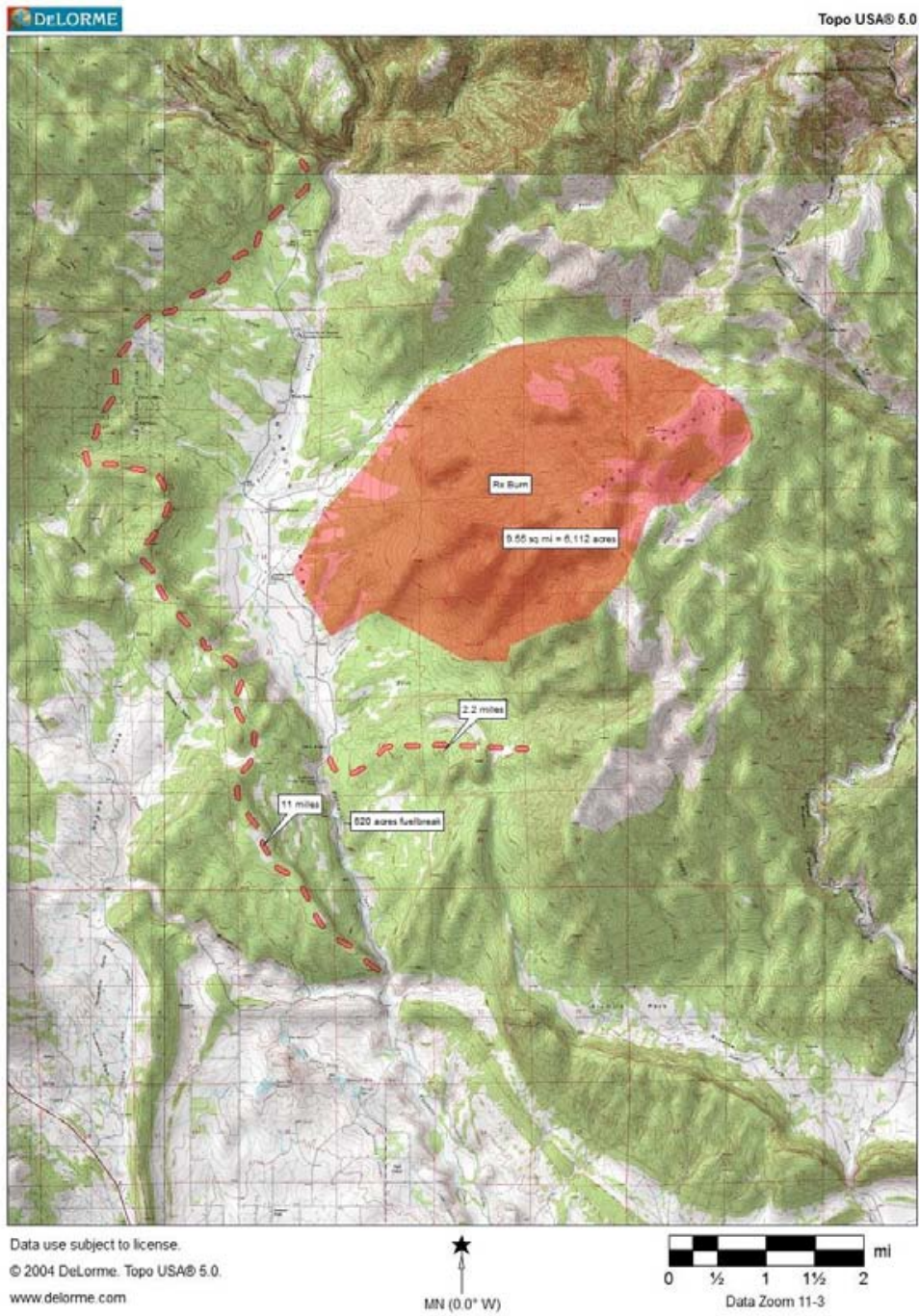

**Table 8: Garden Park Potential Shaded Fuelbreaks**

<b>Fuelbreak Name</b>	<b>Length (miles)</b>	<b>Acres</b>	<b>Estimated cost (\$)</b>	<b>Priority</b>
Southern Fuelbreak	2.2	88	52,800	1
Western Fuelbreak	11	440	264,000	2
<b>Total</b>	<b>13.2</b>	<b>528</b>	<b>316,800</b>	<b>-</b>

This is an extremely optimistic shaded fuelbreak program and will take time to fund in today's Federal budget environment.

***Fuelbreak Maintenance:***

Gamble oak is abundant understory species in the Park. They sprout vigorously after they are cut. Keeping them under control following thinning will be a task. Two methods are effective to keep them in check. Mowing is effective but has to be done on an annual basis. Herbicide treatment is also effective but may be objectionable to some landowners. It will be wise to have a maintenance option in mind prior to fuelbreak construction.

***Treatment Costs:***

Treatment costs for survivable space and shaded fuelbreak work are highly variable depending on the amount of thinning and slash disposal to be done and the relative care involved in doing the work. Hand crews working next to structures and chipping the slash will cost from \$1,000 to \$2,000 per acre. Mechanical thinning with a hydro-ax type machine will normally cost from \$400 to \$700 per acre depending on tree density, slope and rockiness.

***Wildfire Suppression Infrastructure:***

**Turnarounds:**

Space is lacking to turn around fire equipment at the end of most dead end roads. In fact in many cases the terminus is even tight for a full sized pickup truck. Accommodations for turning vehicles around near the end of the road are critical for fire suppression purposes. In some cases there is little room to construct turnarounds at the end of the roads so locating a turnaround as near the end as possible is the only option.

There are many cul de sacs in the Park that need to be improved to sixty four (64') foot radius or a pistol turnaround. It will cost approximately \$10,000 / cul-de-sac to bring them up to an acceptable

standard. Six cul de sacs need to be widened for a total cost of \$60,000. The following roads need to have their cul de sacs improved: Bluff View, Cooper Lane, Cooper Trail, Dilley Ranch, Esperanza and Freck Ranch. See **Appendix H: Road & Driveway Specifications** for design specifics.

“No Outlet” signs are also important during wildfire operations. Most can be placed along the main Garden Park Road. Sixteen are needed at a cost of \$200.00 each for a total of \$3,200.

**Fire Control Features/Triage Maps:**

The maps developed for this Community Wildfire Protection Plan provide invaluable information for wildland firefighting. Reinforcements and mutual aid folks will struggle with the road layout and fire suppression opportunities. Communications can be enhanced by providing high quality maps that show important features.

Fremont County Office of Emergency Management will provide a set of maps and orthophotos to dispatchers, first responders, the Sheriff’s department and Colorado State Forest Service. They will also have a few reserved to distribute during the inevitable emergency.

**Uniform Street Addresses:**

Universal, visible, street addresses are absolutely imperative for first responder effectiveness. Fremont County should adopt a uniform address system for the Park.

**Improving Water Supply for Wildfire Purposes:**

Fourmile Creek, ephemeral ponds and occasional cisterns are providing what meager water there is in GP. Additional sources are needed to support initial and extended wildfire operations and yearlong structure protection. Here are a few options to consider:

Require cisterns on every developed lot. They should be 1,500 to 2,000 gallon tanks that are easy to draft from and follow the standards in item 1 below.

1. Map and sign all existing cisterns and show access and cistern capacity. The cistern will be signed using a red background with 1” white reflective letters containing the following information:



2. Pre-existing residential cisterns may be problematic to access for fire control purposes. Homeowners with cisterns should **provide access for fire control purposes**. Each cistern will have a means to connect a 2.5" NPSH or NH female fitting to the cistern.
3. All new cisterns should meet Canon City Fire Protection District standards outlined below:

**Canon City FPD  
Cistern Standards**

A) Fire District requires new cisterns to meet the applicable section of NFPA 1142 and NFPA 22.

B) Minimum 1000 gallon per minute capacity.

1. At a minimum, strictly for wildland fire operations, a 2-1/2" connection should be supplied. (Does not meet Fire District standards)

2. Fire District requires a 6" NST male connection, with cap, capable of flowing 1000 GPM.

4. Place large cisterns at each of the safety zones and fill them via a watershed type apron. Eighteen inches (18") of annual precipitation will fill a 20,000 gallon tank with a catchment apron 45' x45'. Large cisterns will meet NFPA Supplemental Water specifications.
5. Determine the integrity and capacity of the cistern at the Garden Park school house.
6. Provide fire access to the Park Center well being developed along Garden Park road on the south end of GP.
7. Drill a couple high yield (1,000 gpm.) fire wells. Locating an aquifer capable of supplying this flow is problematic in GP. Water rights will also have to be acquired for these wells. OR Run pipeline north from Park Center Well.
8. Explore availability of a new well near Cooper Mountain subdivision.
9. Have all initial attack responses in GP include several nurse tankers.

10. Utilizing Fourmile Creek and pond water for wildfires: Several ponds in the Park are adjacent to good roads. Getting fire equipment close enough to draft and fill the tanks may be problematic due to elevation and drafting capability of individual pieces of equipment. The most reliable method to fill tanks is with mechanical high volume or high pressure pumps. The most flexible system to transfer pond water to fire trucks is the “Floto-Pump”. This light weight pump can be carried by one person and is simple to operate. You merely connect a hose to the pump, place it in the pond and start it. The pump floats on the pond and primes itself. The pump can also be placed in a large folding tank to provide high pressure water while an engine shuttles water from the closest hydrant.
11. Determine feasibility of designating Fire Wells on Bud Chess’, Curt Sorenson’s places.

### ***Evacuation Planning:***

The best option for evacuations that are expected to last for several days is to get all civilians out of harms way and in comfortable alternative accommodations. This means getting livestock relocated and people down the Garden Park Road in an orderly and timely way while fire resources are using the same road to access the fire

One factor to consider and perhaps address directly in the Evacuation Plan is the amount of time it will take to fully implement in comparison to the expected fire behavior described in **Table 2: Garden Park Fire Behavior Prediction**. Fire spread rates of half mile per hour and spotting distances of close to a quarter mile mean that evacuations should probably be implemented when any fire is within 3 miles of a structure during high or greater fire danger periods.

Just making sure everyone is notified will be a daunting task given the twenty six miles of road/driveways and 148 structures scattered throughout the 37,319 acre GP. This situation can be further complicated with off-site property owners visiting their land and recreationists on public lands.

An evacuation simulation exercise would be an eye-opener for Park residents and should be scheduled for next spring. This test run will give everyone involved a better sense of the task at hand.

There is one primitive road that joins Cooper Trail with Cooper Lane. It is currently not passable with normal highway vehicles but could be made so with permission form the involved landowners.

### **Evacuation Option:**

With an increasing number of residents and changing distribution of population in the Park it may be prudent to designate specific Safety Zones for residents to use, keeping in mind common evacuation routes for each locale.

During a rapidly evolving wildfire or if the fire has burned across CR9 there are several good Safety Zones in GP. These Safety Zones should be considered stop gap solutions as they are not well suited for situation where the evacuation order is expected to last for more than a few hours.

### ***Strategic Recommendations:***

The Garden Park CWPP Core Team is composed of paid agency employees and HOA or resident volunteers who are all dedicated but over committed and there is no full time focus in pre-planning, hazard detection, follow up, communications, coordination, and/or implementation of improvements. The community does not have a mechanism for administering multiple demands, setting priorities, and insuring representation that benefits the community as a whole.

In order to strengthen the ability for GP to implement the Community Wildfire Protection Plan Canon City FPD will seek funds to employ a coordinator or project manager to ensure implementation of the Plan and other CWPPs in development, including the required overall leadership, management, and activity coordination. In addition the position would be responsible for such items as overseeing development of survivable space in the community and generation of grants for the implementation of the Community Wildfire Protection Plan with the Colorado State Forest Service.

### ***Fire Protection Situation:***

Approximately 63% of the structures in Garden Park are within the Canon City Fire Protection District. The remaining structures do not have any organized fire protection and simply rely on the good graces of the Canon City Fire Protection District, Fremont County Sherriff, BLM and Forest Service.

Including more area with organized fire protection is not a simple task. It is fraught with many obstacles, some of them seem difficult to overcome. Colorado State Law Title 32 Article 1 Part 4 Special Districts, describes the steps to be included in an existing district. Part 2 of the same Title and Article describes the steps to create a new Special Tax District. It is far beyond the scope of this CWPP to resolve the fire protection issue but it is not unreasonable for the CWPP to outline several options and perhaps get the ball rolling to find a solution to the present dilemma.

One of the following options may actually be a viable way to expand organized fire protection for the Garden Park area:

- Interested parties negotiate an agreement with Canon City FPD to provide fire services for a fee.
- Individual or a group petition to be included into the Canon City FPD.
- Form a new, freestanding Garden Park Fire Protection District.

The CWPP’s role on this topic is to stimulate discussion and assign a group of interested parties the task of fleshing out the best solution given the facts and energies available to solve the issue.

**Table 9: Comparison of Options to Enhance Fire Protection District Coverage**

Option	Pros	Cons
Negotiate individual agreements w/CCFPD	Relatively simple, least cost	Still may be considered expensive by some landowners.
Group petition to be included in CC FPD	Provides coverage for most people	Requires 100% agreement of those in area to be annexed by CC FPD. May be cost prohibitive for CC FPD
Form new – independent FPD that covers entire Garden Park area. CCFPD would relinquish its’ GP territory to new entity	Provides coverage for entire Garden Park area under one fire protection entity	Requires significant investment in fire station, equipment, recruitment and training of volunteers. Unknown availability of suitable volunteers

#### IV. IMPLEMENTATION & MONITORING

***Implementation:***

**Table 10: Implementation Items Priority & Cost** lists all the mitigation actions/projects identified in this CWPP. There are also an estimated fifty three (53) structures that need to have their survivable space improved.

**Table 11: Action Plan for Completing the Garden Park CWPP**, identifies the responsibilities and tasks necessary to accomplish the job at hand. The priorities and responsibilities have been negotiated and agreed to by the Core Team and the various named individuals.



**Table 10: Implementation Items Priority & Cost**

Mitigation Action	Priority	Estimated Cost (\$s)
Conduct FireWise and Survivable Space Workshops and provide onsite advice	1	5,000 annually
Survivable Space Around All Structures (\$5,000/lot)	1	5,000/ lot
Encourage residents to stay current in the E911 system (Public Service Announcements)	1	0
Mark and map all existing cisterns on Fire Control Features map	2	15,000
Develop reliable water supply for wildfire operations (organize a group)	2	?
Develop an Evacuation Plan	3	5,000
Install 16 “No Outlet” signs on dead end roads	3	3,200
Negotiate and document rights to use Safety Zones	4	0
Print & distribute Fire Control Features Maps (20 sets)	5	4,500
Develop a unified fire prevention program for Red Canyon & Shelf Road Climbing Area	6	1,500
Evacuation Simulation	7	3,000
Organize a group to explore organized fire protection issue	8	0
Reconstruct (6) cul de sacs to at least 64’ diameter	9	60,000
Purchase additional fire apparatus for Canon City FPD and hire additional firefighters	10	1,500,000
Landscape Scale Fuels Treatments:	11	
South Shaded Fuelbreak		66,000
Western Shaded Fuelbreak		330,000
Conduct Rx Burns on Cooper Mtn.		1,833,600
Fuel Break Maintenance	12	20,000/annum

**Monitoring:**

Plans do not complete themselves. Monitoring progress is a crucial part of seeing any plan through to completion. Given the values at risk in Garden Park, it will be important to take a pulse on accomplishments on an annual basis. We expect more homes to become survivable and maps will have to be revised to reflect the work that has been accomplished. The OEM will revisit the CWPP and associated accomplishments each fall and will get new maps printed as accomplishments warrant.

- Through the Canon City FPD; seek funds for the purpose of hiring and possibly cost- sharing a coordinator (implementation manager) who, among other things, would do the following:
  - Provide the leadership needed to implement this plan.
  - Establish a prevention attitude in the community for wildfire.

- Strengthen public understanding, acceptance and participation in GPCWPP operations and improvement projects.
- Insure follow up to commitments by the community or within the community and on behalf of the GPCWPP goals.
- Facilitate the organization of an ongoing cooperative management team consisting of members from the Core Team, HOAs and Fremont County officials. This group will act as an advisory board to represent the community as a whole. This entity would do the following:
  - Set priorities, develop and administer fund raising activities, interact with and coordinate with County, coordinate with State and Federal agencies on behalf of the community as a whole, and insure follow up on all operations and or activities.

**Table 11: Action Plan for Completing the Garden Park CWPP**

Mitigation Action	Target Date	Assigned to	Completed ✓
Conduct FireWise and Survivable Space Workshops and provide onsite advice	Ongoing	CSFS, CCFPD, Curt Sorenson	
Encourage residents to stay current in the E911 system	On-going	CSFS, CCFPD, Curt Sorenson	
Survivable Space Around All Structures (\$5,000/lot)	ASAP	Individual landowners	
Mark location of all existing/serviceable cisterns & place on Fire Control Features Maps	ASAP	Individual landowners	
Develop reliable water supply for wildfire operations	April 2014	Curt Sorenson, Ed Skerjanec, Dave D.	
Develop a unified fire prevention program for Red Canyon & Shelf Road Climbing Area	April 2014	Ed Skerjanec Steve Morrissey	
Negotiate and document rights to use Safety Zones	April 2014	Roger Motz	
Develop an Evacuation Plan	April 2014	Steve Morrissey Dave D.	
Print & distribute Fire Control Features Maps (20 sets)	May 2014	Ed Skerjanec Steve Morrissey	
Install 16 "No Outlet" signs on dead end roads	May 2014	Colleen Bobinac	
Evacuation Simulation	May 2014	Steve Morrissey Dave D.	
Reconstruct (6) cul de sacs to at least 64' diameter	3-4 Years	Home Owners Association Colleen B. Dilley Ranches	
Organize a group to explore organized fire protection issue	September 2014	Roger Motz	
Procure additional fire apparatus and hire additional firefighters	April 2015	David DeVecchio	
South Shaded Fuel break.	Contingent on Funding	BLM/Fremont Conservation Dist	
Western Shaded Fuel break.	Contingent on Funding	BLM/Fremont Conservation Dist	
Conduct Rx Burns on Cooper Mtn.	Contingent on Funding	BLM/Fremont Conservation Dist	
Fuelbreak maintenance	Contingent on Funding	BLM/Fremont Conservation Dist	

## *Appendix A - Maps*

# Garden Park Triage & Fire Control Features

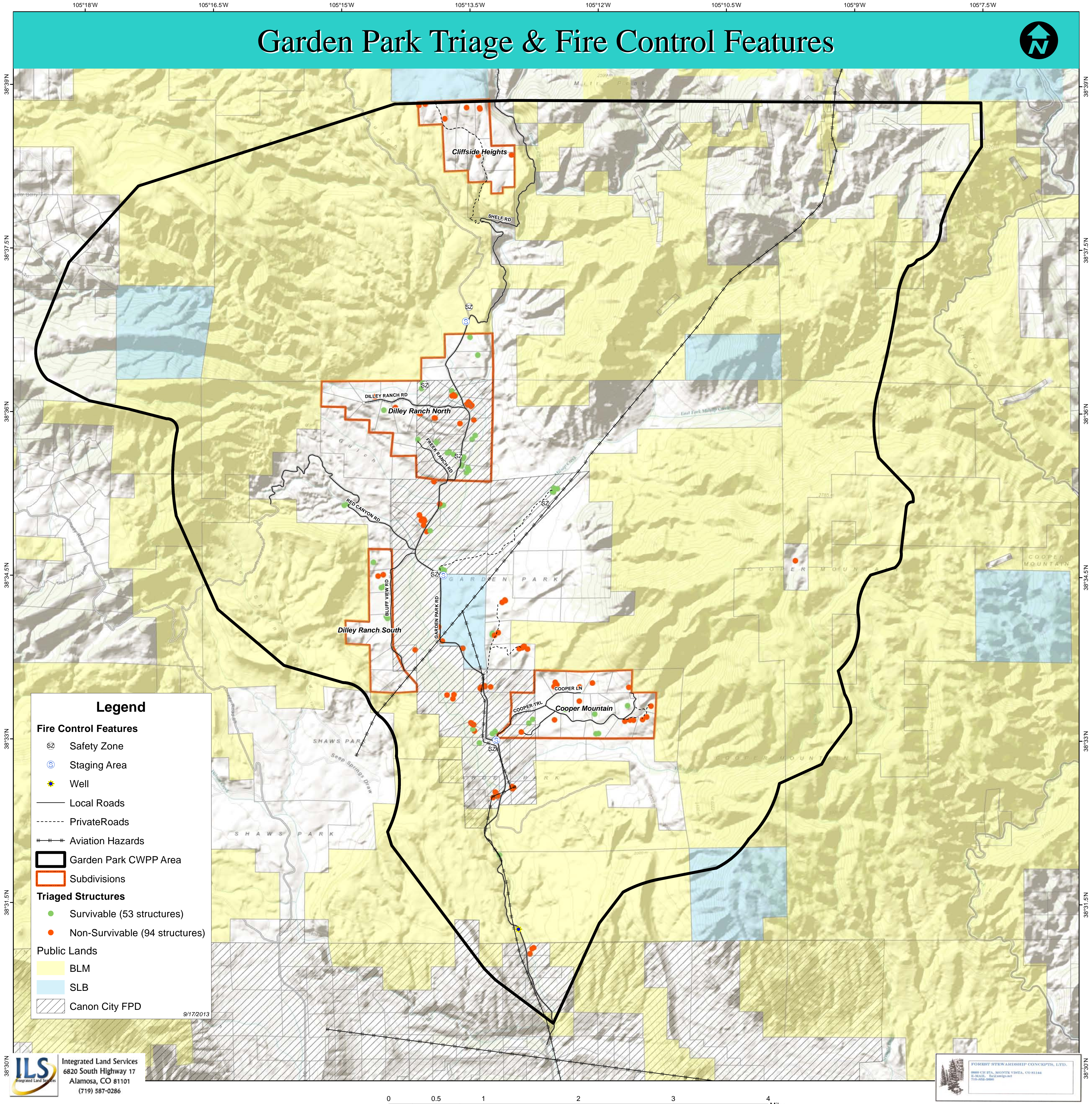

## Legend

### Fire Control Features

- Safety Zone
- Staging Area
- Well
- Local Roads
- Private Roads
- Aviation Hazards

Garden Park CWPP Area

Subdivisions

### Triaged Structures

- Survivable (53 structures)
- Non-Survivable (94 structures)

### Public Lands

- BLM
- SLB
- Canon City FPD

9/17/2013

# Garden Park Triage & Fire Control Features

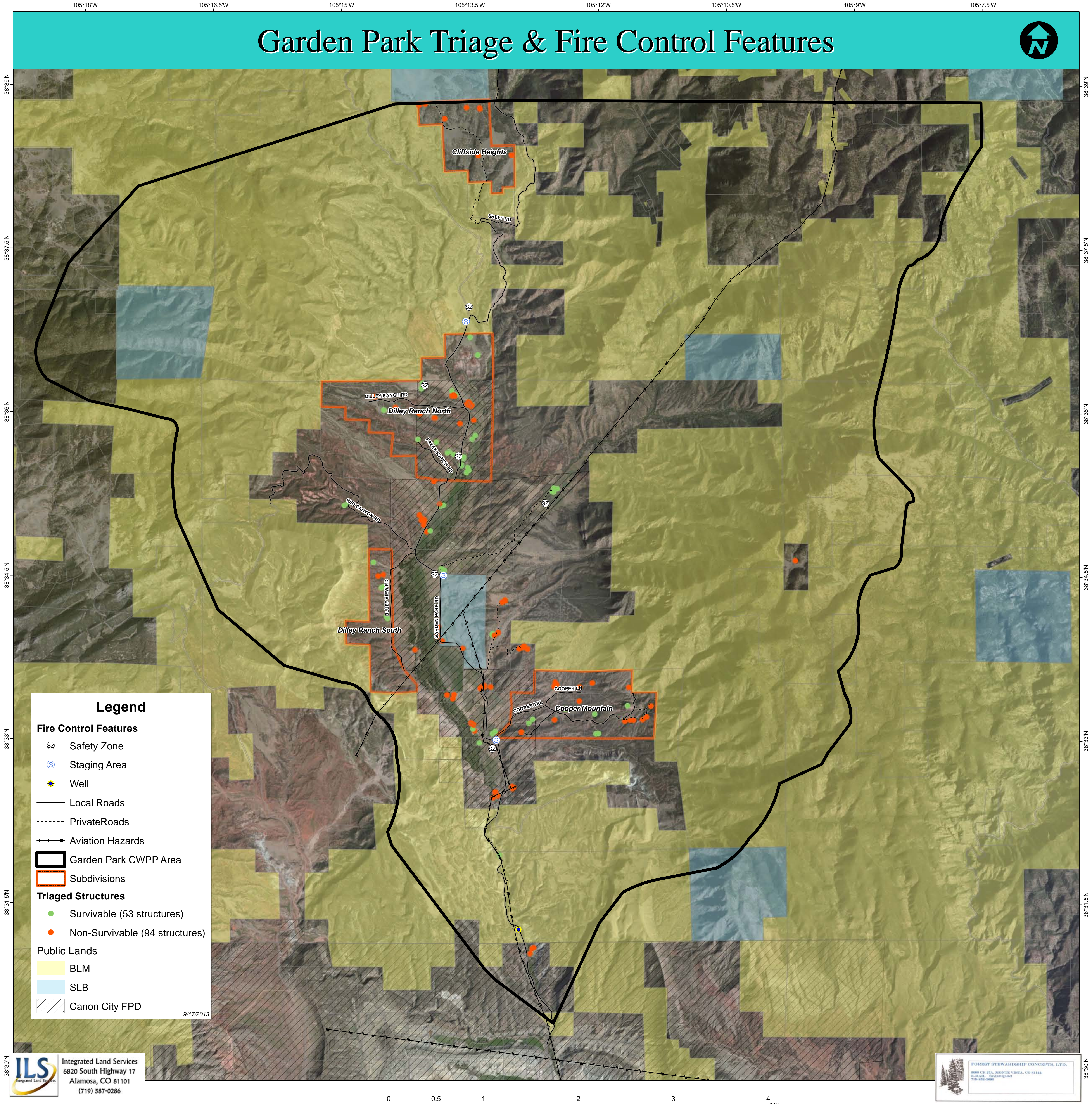

**Legend**

**Fire Control Features**

- SZ Safety Zone
- SA Staging Area
- Well
- Local Roads
- Private Roads
- Aviation Hazards
- Garden Park CWPP Area
- Subdivisions

**Triaged Structures**

- Survivable (53 structures)
- Non-Survivable (94 structures)

**Public Lands**

- BLM
- SLB
- Canon City FPD

9/17/2013

105°18'W

105°16.5'W

105°15'W

105°13.5'W

105°12'W

105°10.5'W

105°9'W

105°7.5'W

# Garden Park Topography

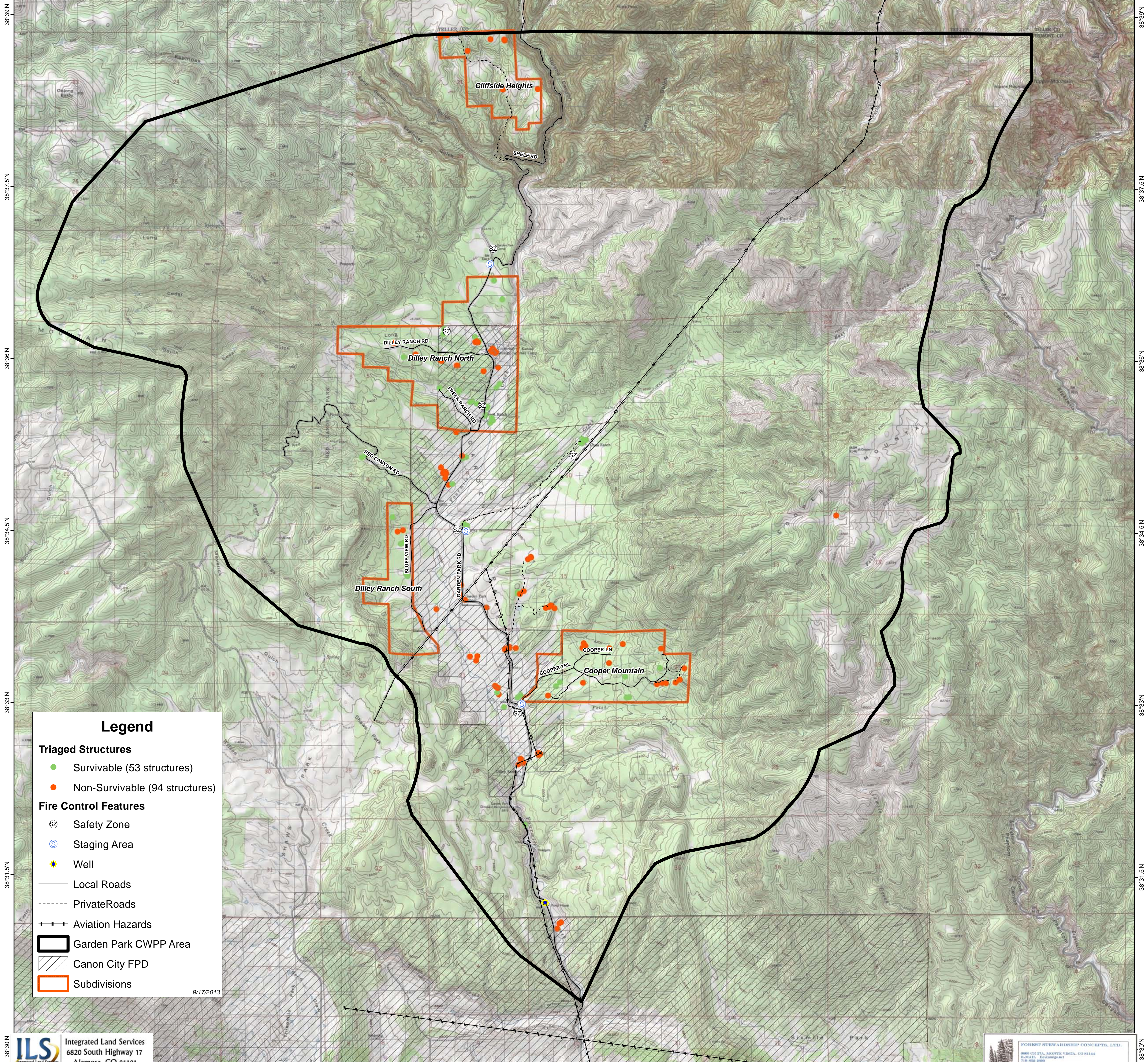

## Legend

### Triaged Structures

- Survivable (53 structures)
- Non-Survivable (94 structures)

### Fire Control Features

- ⊙ Safety Zone
- ⊙ Staging Area
- ★ Well
- Local Roads
- - - Private Roads
- ▨ Aviation Hazards
- ▭ Garden Park CWPP Area
- ▨ Canon City FPD
- ▭ Subdivisions

9/17/2013



Integrated Land Services  
6820 South Highway 17  
Alamosa, CO 81101  
(719) 587-0286

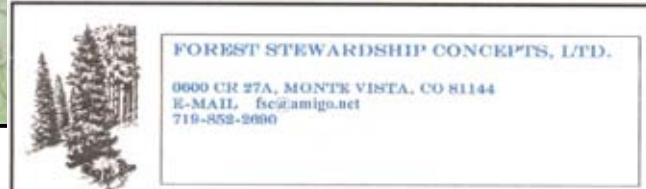
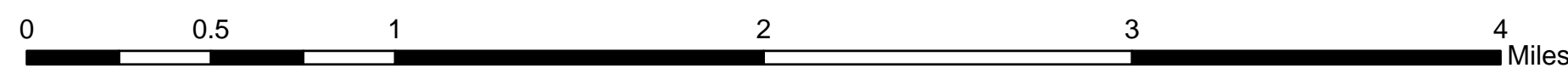

# Garden Park Slope

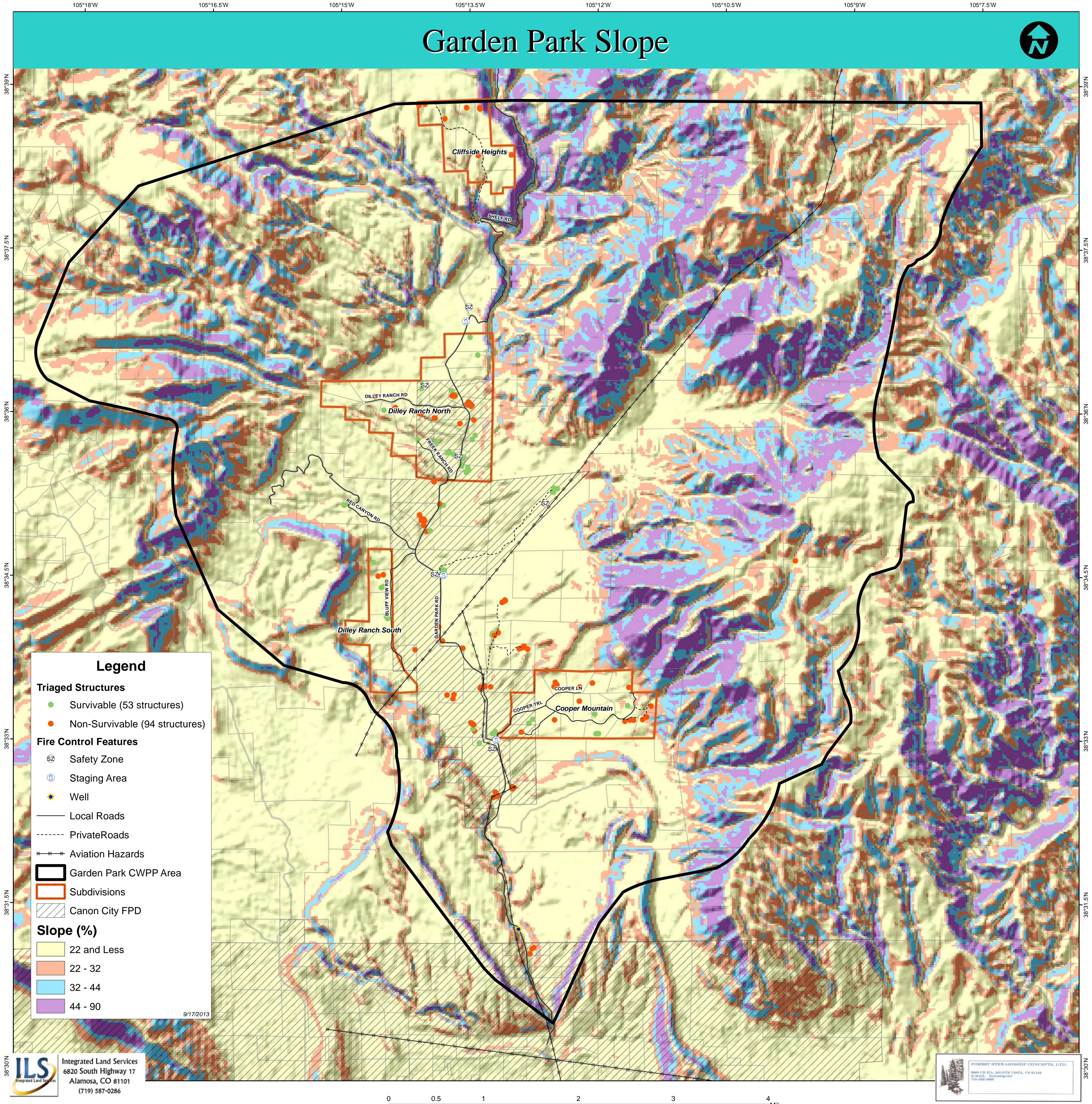

## Legend

### Triaged Structures

- Survivable (53 structures)
- Non-Survivable (94 structures)

### Fire Control Features

- Ⓢ Safety Zone
- Ⓢ Staging Area
- ⚡ Well
- Local Roads
- - - Private Roads
- ⊘ Aviation Hazards
- ▭ Garden Park CWPP Area
- ▭ Subdivisions
- ▨ Canon City FPD

### Slope (%)

- 22 and Less
- 22 - 32
- 32 - 44
- 44 - 90

9/17/2013

# Garden Park Vegetation

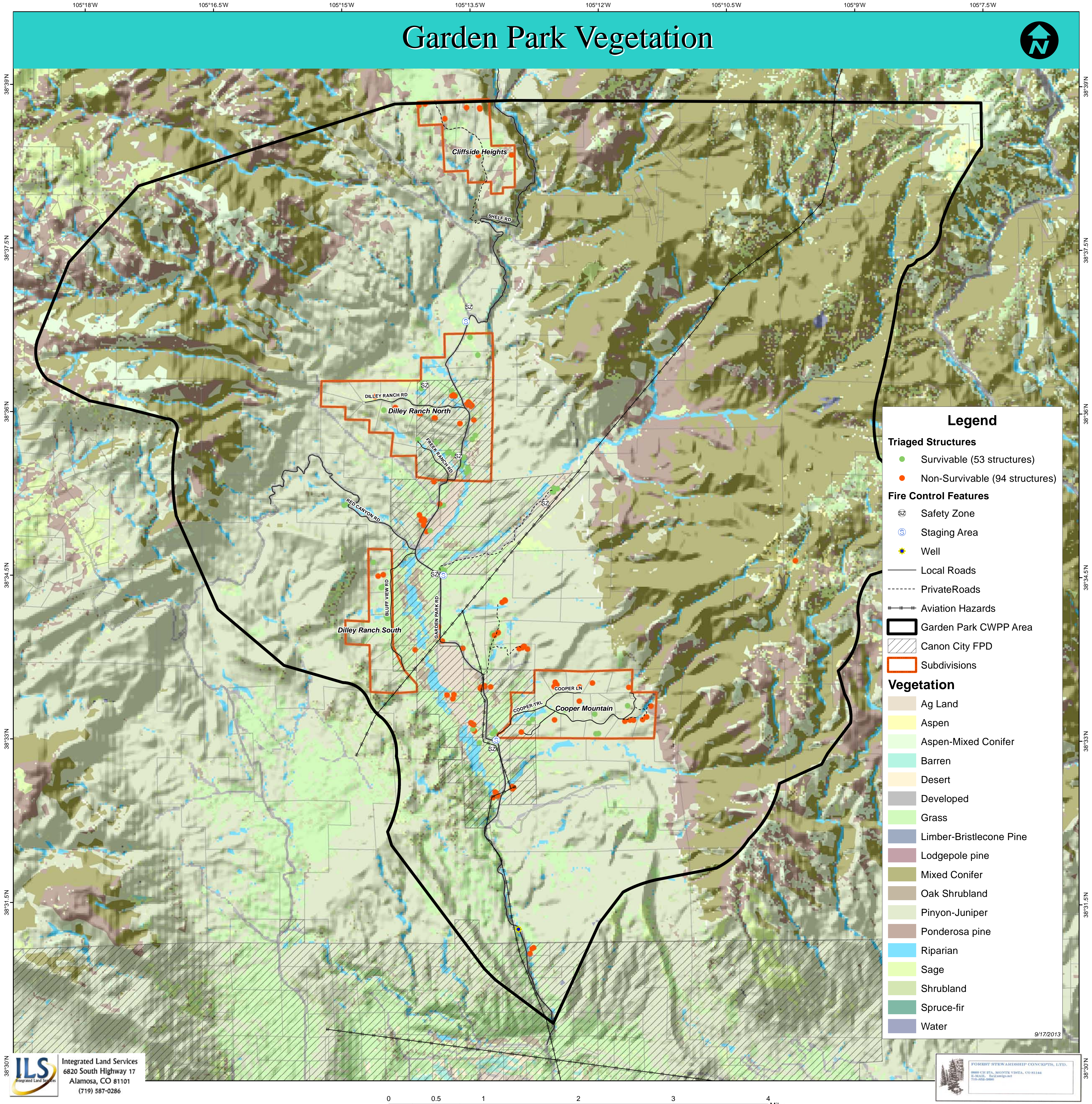

### Legend

**Triaged Structures**

- Survivable (53 structures)
- Non-Survivable (94 structures)

**Fire Control Features**

- ⊗ Safety Zone
- ⊙ Staging Area
- ★ Well
- Local Roads
- - - Private Roads
- ⚡ Aviation Hazards
- ▭ Garden Park CWPP Area
- ▨ Canon City FPD
- ▭ Subdivisions

**Vegetation**

- Ag Land
- Aspen
- Aspen-Mixed Conifer
- Barren
- Desert
- Developed
- Grass
- Limber-Bristlecone Pine
- Lodgepole pine
- Mixed Conifer
- Oak Shrubland
- Pinyon-Juniper
- Ponderosa pine
- Riparian
- Sage
- Shrubland
- Spruce-fir
- Water

9/17/2013

**ILS** Integrated Land Services  
 6820 South Highway 17  
 Alamosa, CO 81101  
 (719) 587-0286

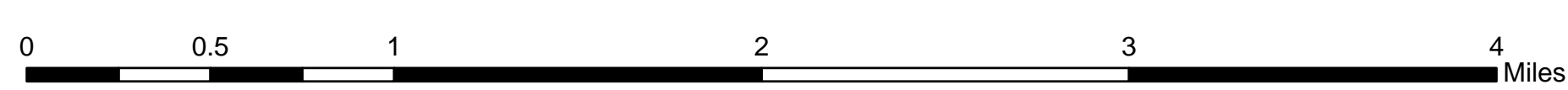

**FORBES STEWARDSHIP CONCEPTS, LTD.**  
 8000 CH. STA. MONTE VISTA, CO 81144  
 P.O. BOX 1000  
 719-285-0800



# Garden Park Existing and Future Fuel Treatments

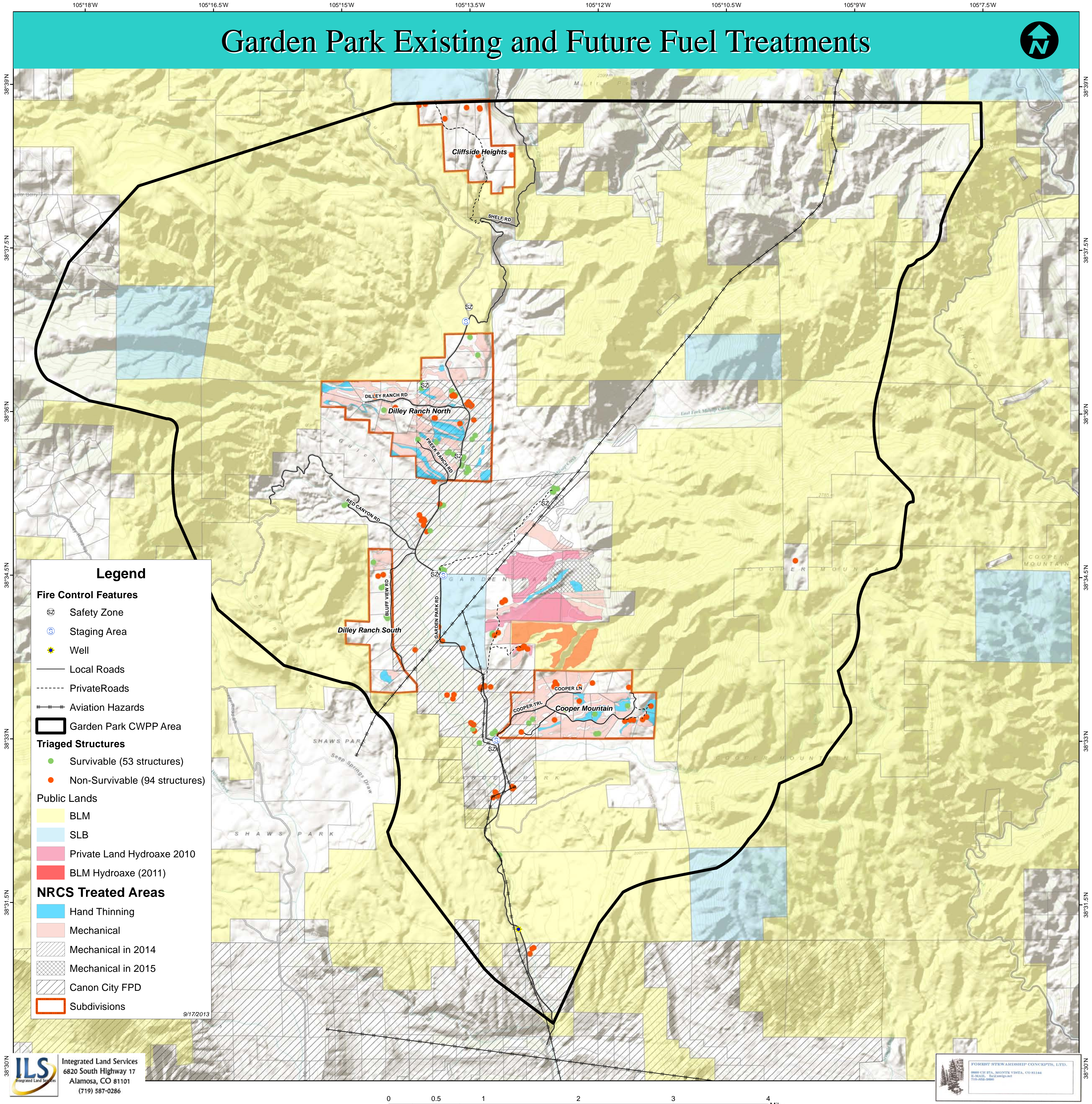

## Legend

### Fire Control Features

- Safety Zone
- Staging Area
- Well
- Local Roads
- Private Roads
- Aviation Hazards

- Garden Park CWPP Area

### Triaged Structures

- Survivable (53 structures)
- Non-Survivable (94 structures)

### Public Lands

- BLM
- SLB
- Private Land Hydroxide 2010
- BLM Hydroxide (2011)

### NRCS Treated Areas

- Hand Thinning
- Mechanical
- Mechanical in 2014
- Mechanical in 2015
- Canon City FPD
- Subdivisions

9/17/2013

105°18'W

105°16.5'W

105°15'W

105°13.5'W

105°12'W

105°10.5'W

105°9'W

105°7.5'W

# Garden Park Fuel Model

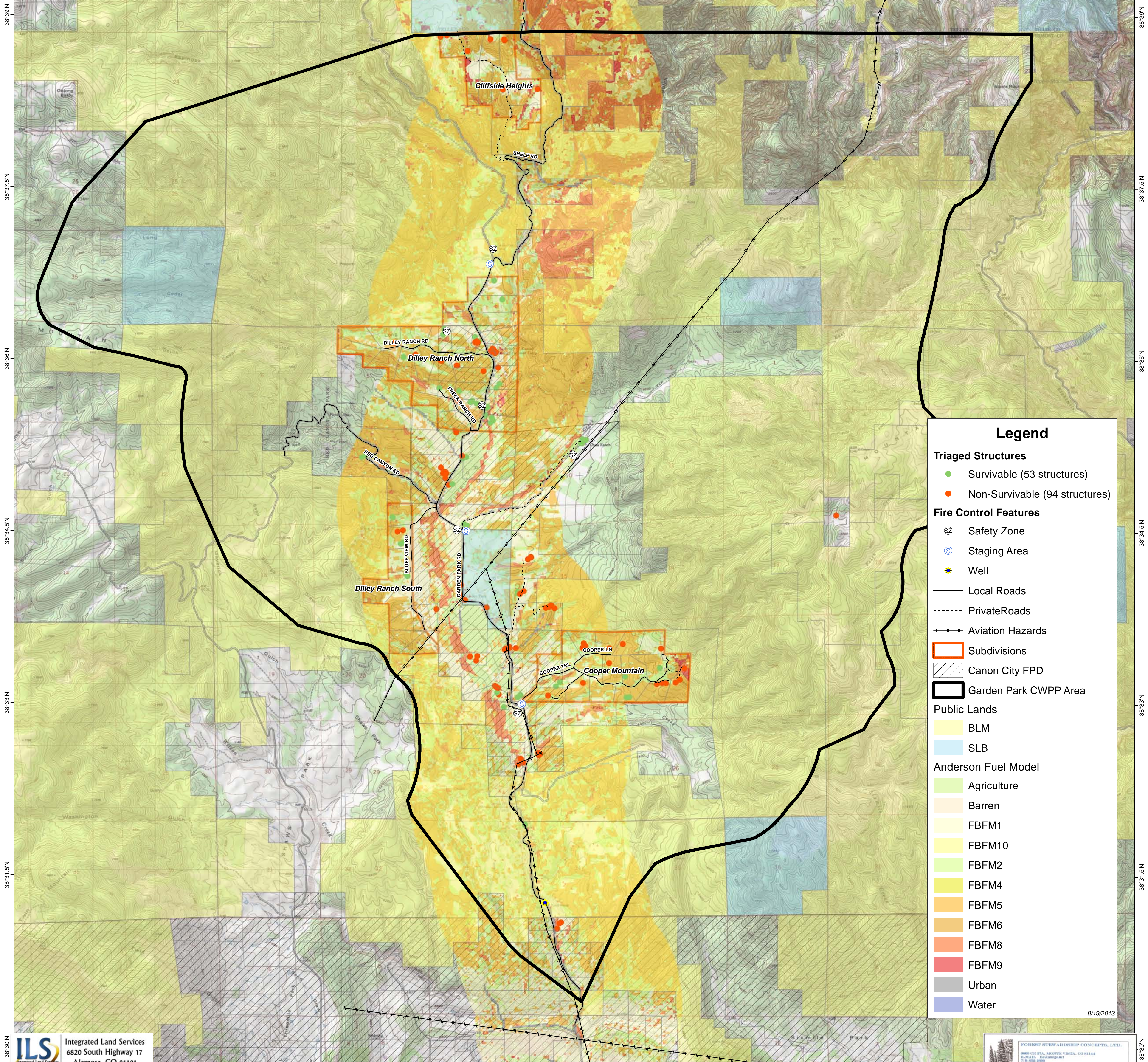

## Legend

### Triaged Structures

- Survivable (53 structures)
- Non-Survivable (94 structures)

### Fire Control Features

- ⊗ Safety Zone
- ⊙ Staging Area
- ⚡ Well
- Local Roads
- - - Private Roads
- ⚡ Aviation Hazards

- ▭ Subdivisions
- ▨ Canon City FPD
- ▭ Garden Park CWPP Area

### Public Lands

- BLM
- SLB

### Anderson Fuel Model

- Agriculture
- Barren
- FBFM1
- FBFM10
- FBFM2
- FBFM4
- FBFM5
- FBFM6
- FBFM8
- FBFM9
- Urban
- Water

9/19/2013

# Cliffside Heights Triage & Fire Control Features



38°38.5'N

38°38.5'N

38°38'N

38°38'N

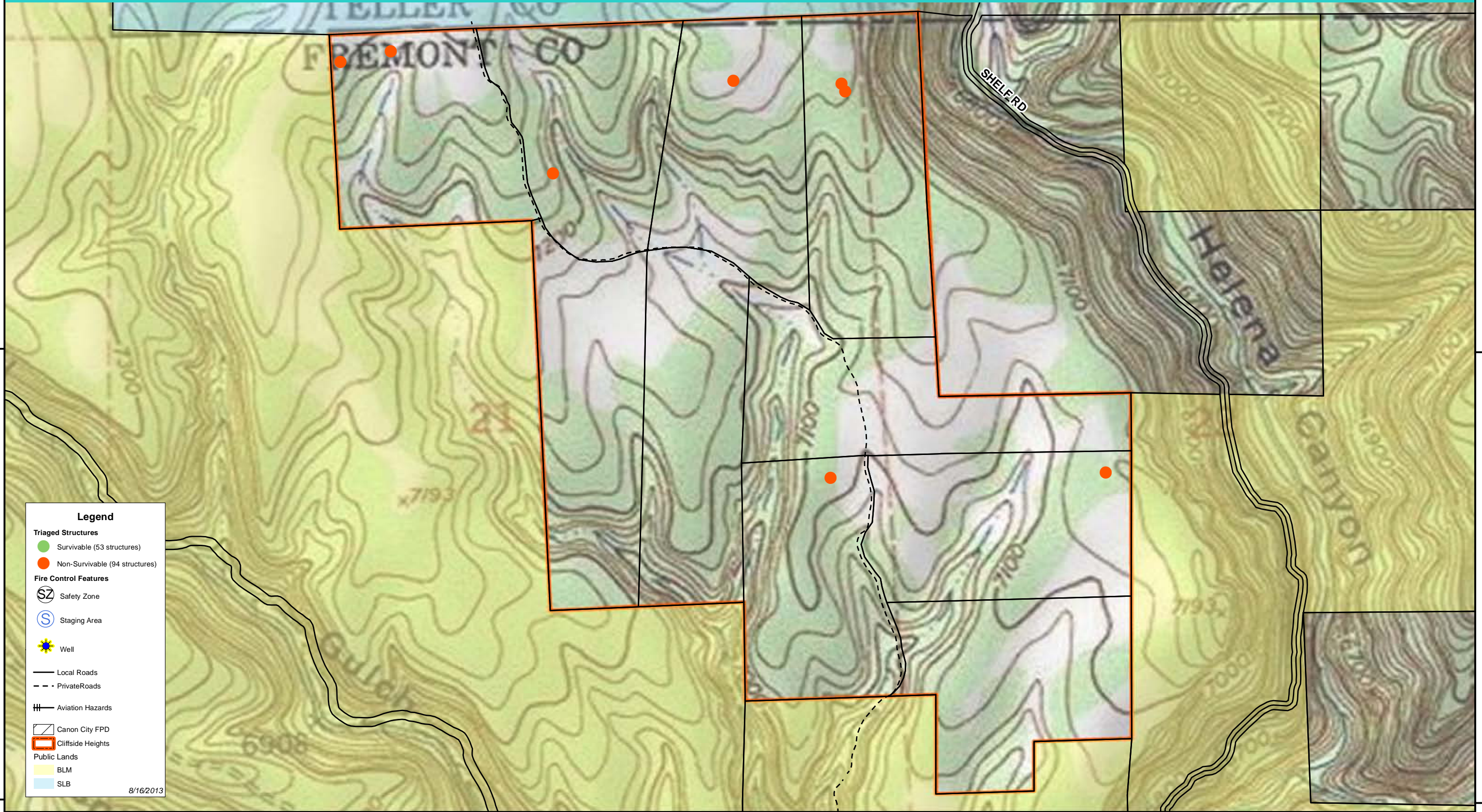

**Legend**

**Triaged Structures**

- Survivable (53 structures)
- Non-Survivable (94 structures)

**Fire Control Features**

- Safety Zone
- Staging Area
- Well
- Local Roads
- Private Roads
- Aviation Hazards
- Canon City FPD
- Cliffside Heights

**Public Lands**

- BLM
- SLB

8/16/2013

105°14.5'W

105°14'W

105°13.5'W

105°13'W

105°12.5'W

# Cliffside Heights Triage & Fire Control Features



38°38.5'N

38°38.5'N

38°38'N

38°38'N

**Legend**

**Triaged Structures**

- Survivable (53 structures)
- Non-Survivable (94 structures)

**Fire Control Features**

- Safety Zone
- Staging Area
- Well
- Local Roads
- Private Roads
- Aviation Hazards
- Canon City FPD
- Cliffside Heights

**Public Lands**

- BLM
- SLB

8/16/2013

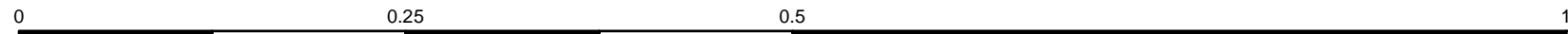

105°14'W

105°13.5'W

105°13'W

105°12.5'W

105°12'W

105°11.5'W

105°11'W

# Cooper Mountain Triage & Fire Control Features

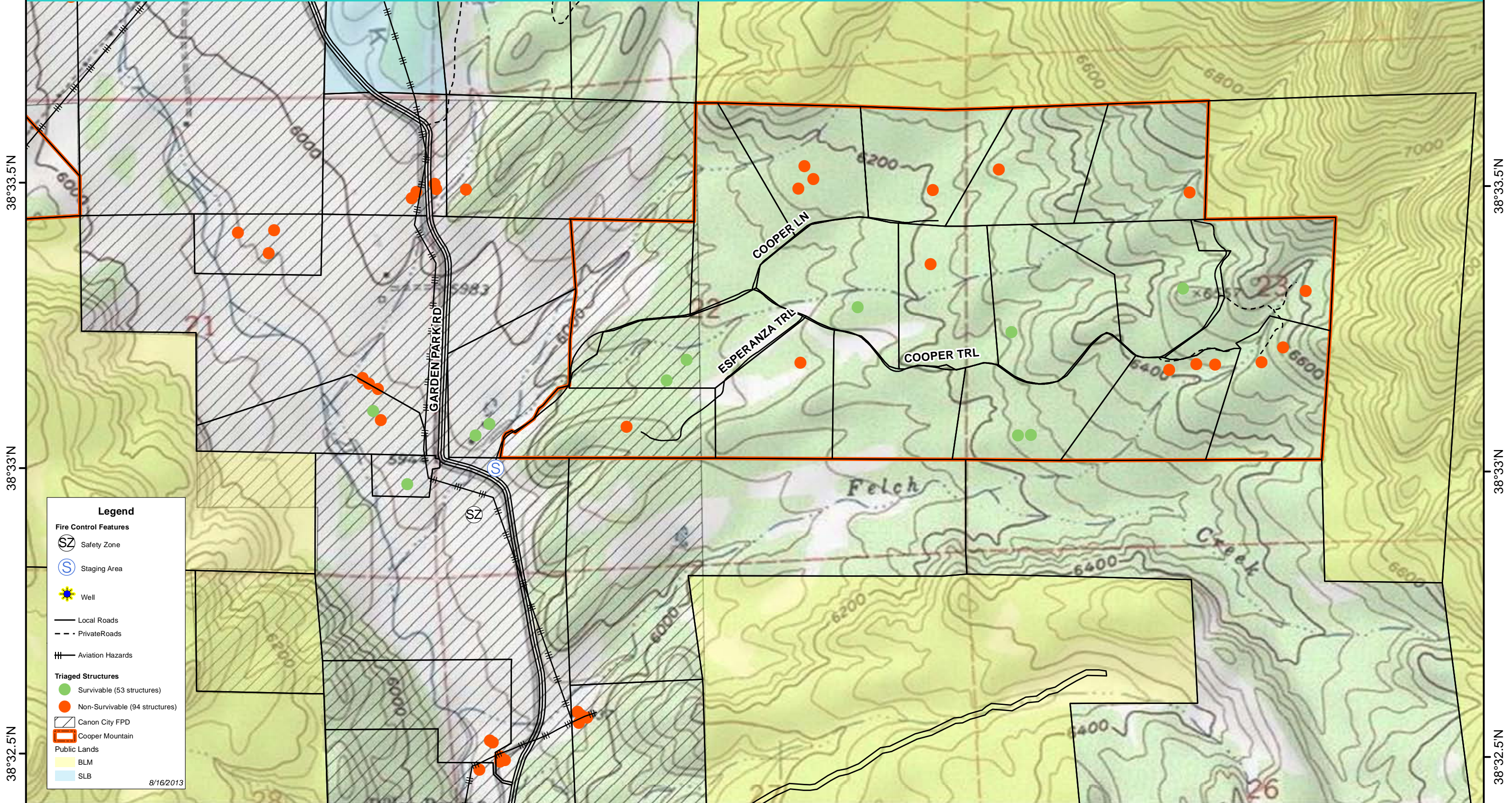

105°14'W

105°13.5'W

105°13'W

105°12.5'W

105°12'W

105°11.5'W

105°11'W

# Cooper Mountain Triage & Fire Control Features

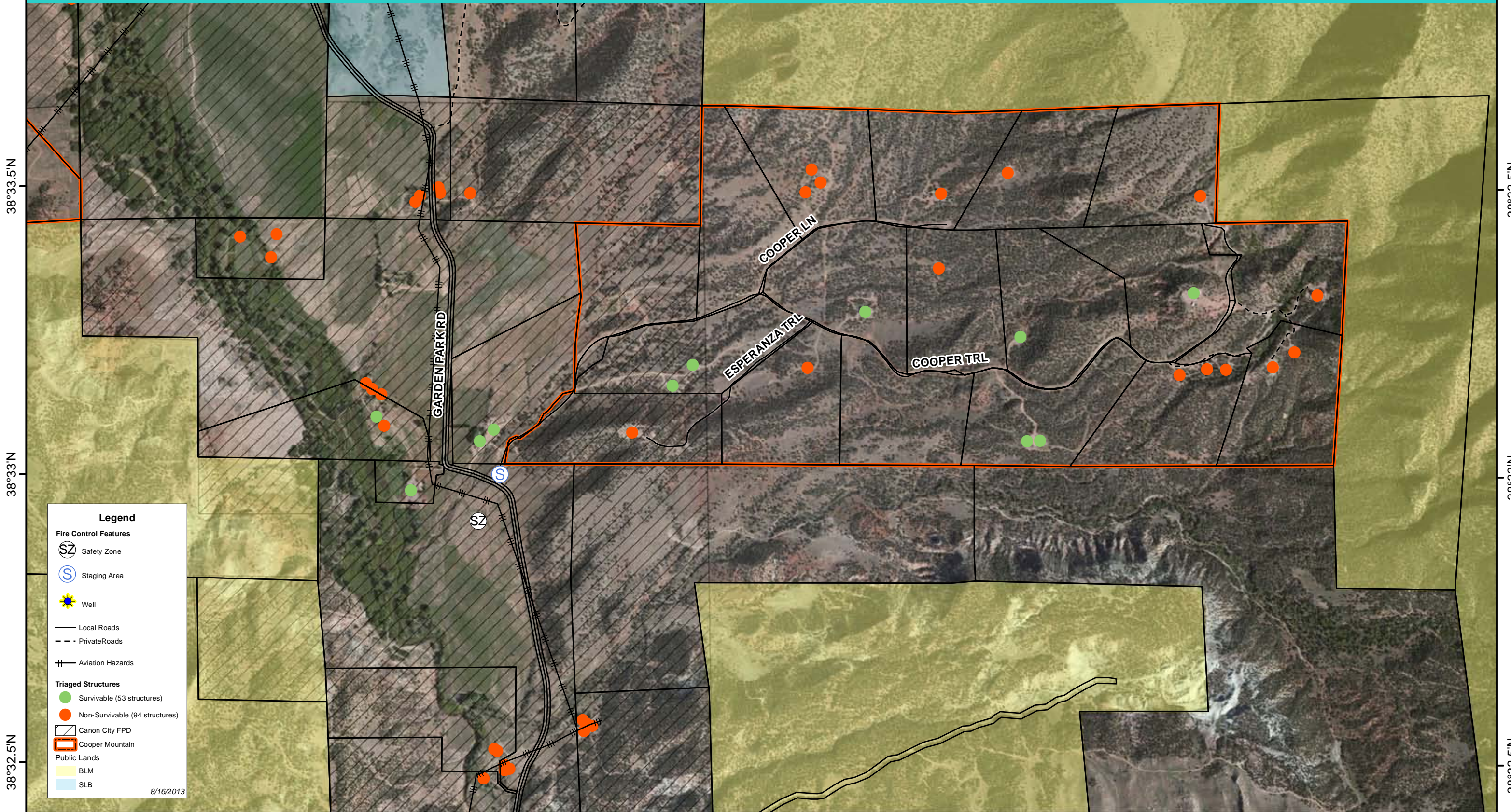

105°15.5'W

105°15'W

105°14.5'W

105°14'W

105°13.5'W

105°13'W

105°12.5'W

# Dilley Ranch North Triage & Fire Control Features



38°36.5'N

38°36.5'N

38°36'N

38°36'N

38°35.5'N

38°35.5'N

**Legend**

**Triaged Structures**

- Survivable (53 structures)
- Non-Survivable (94 structures)

**Fire Control Features**

- Safety Zone (SZ)
- Staging Area (S)
- Well
- Local Roads
- Private Roads
- Aviation Hazards
- Canon City FPD
- Dilley Ranch North
- Public Lands
- BLM
- SLB

8/12/2013

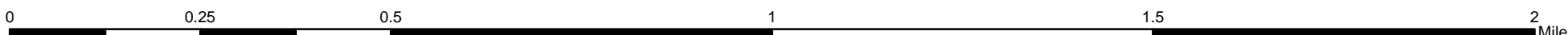

105°15.5'W

105°15'W

105°14.5'W

105°14'W

105°13.5'W

105°13'W

105°12.5'W

# Dilley Ranch North Triage & Fire Control Features



38°36.5'N

38°36.5'N

38°36'N

38°36'N

38°35.5'N

38°35.5'N

**Legend**

**Triaged Structures**

- Survivable (53 structures)
- Non-Survivable (94 structures)

**Fire Control Features**

- Safety Zone
- Staging Area
- Well
- Local Roads
- Private Roads
- Aviation Hazards
- Canon City FPD
- Dilley Ranch North

**Public Lands**

- BLM
- SLB

8/12/2013

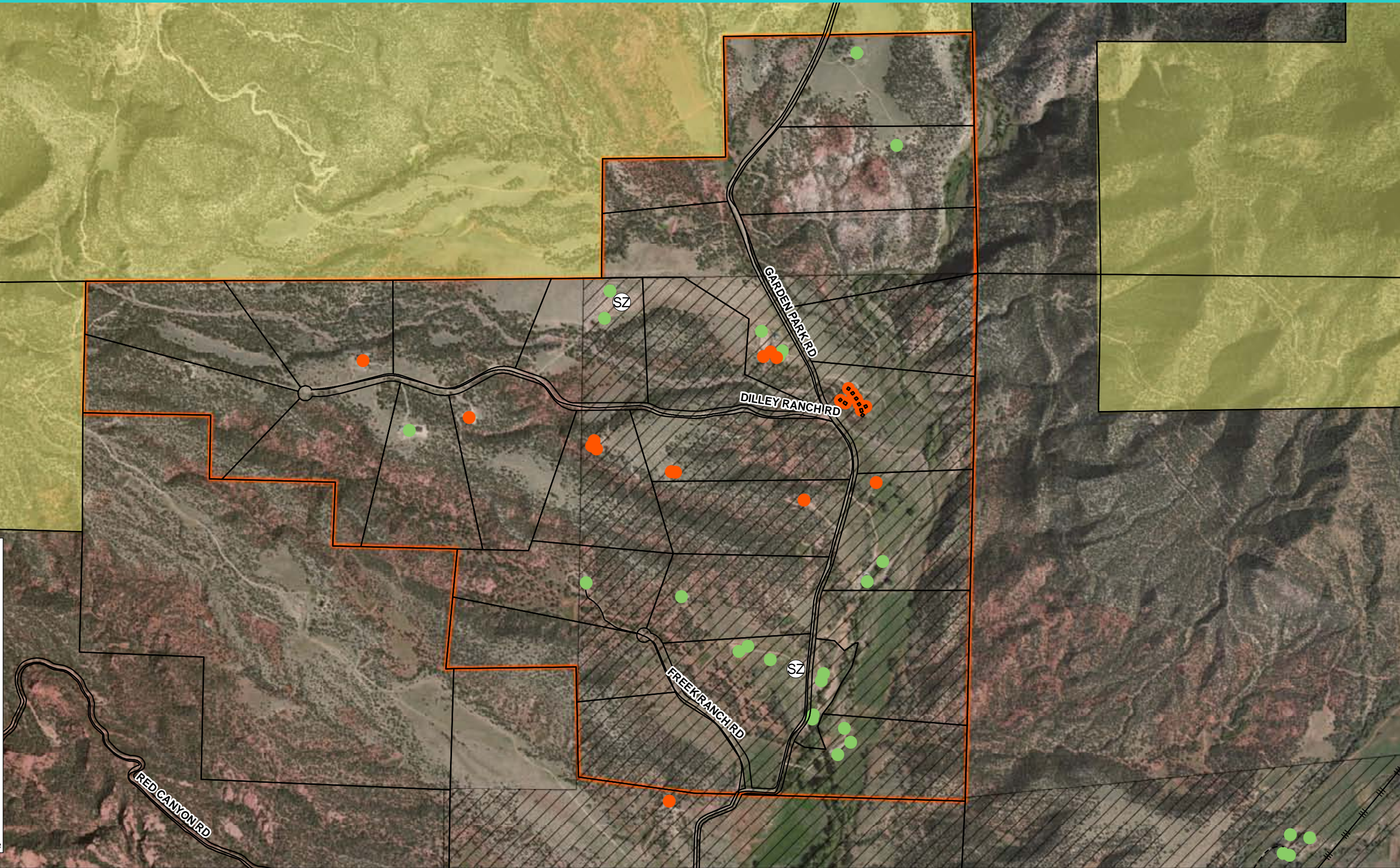



105°15'W

105°14.5'W

105°14'W

# Dilley Ranch South Triage & Fire Control Features



38°34.5'N

38°34.5'N

38°34'N

38°34'N

38°33.5'N

38°33.5'N

**Legend**

**Fire Control Features**

- Safety Zone
- Staging Area
- Well
- Local Roads
- Private Roads
- Aviation Hazards

**Triaged Structures**

- Survivable (53 structures)
- Non-Survivable (94 structures)

**Public Lands**

- Canon City FPD
- Dilley Ranch South
- BLM
- SLB

8/18/2013



Integrated Land Services  
 6820 South Highway 17  
 Alamosa, CO 81101  
 (719) 587-0286



105°15'W

105°14.5'W

105°14'W

# Dilley Ranch South Triage & Fire Control Features



38°34.5'N

38°34.5'N

38°34'N

38°34'N

38°33.5'N

38°33.5'N

**Legend**

**Fire Control Features**

- Safety Zone
- Staging Area
- Well
- Local Roads
- Private Roads
- Aviation Hazards

**Triaged Structures**

- Survivable (53 structures)
- Non-Survivable (94 structures)

**Public Lands**

- Canon City FPD
- Dilley Ranch South
- BLM
- SLB

8/18/2013



Integrated Land Services  
6820 South Highway 17  
Alamosa, CO 81101  
(719) 587-0286



# GARDEN PARK AREA ASPECT MAP

FREMONT/TALLAHASSEE  
RURAL FIRE  
PROTECTION ASSOC

NO FPD

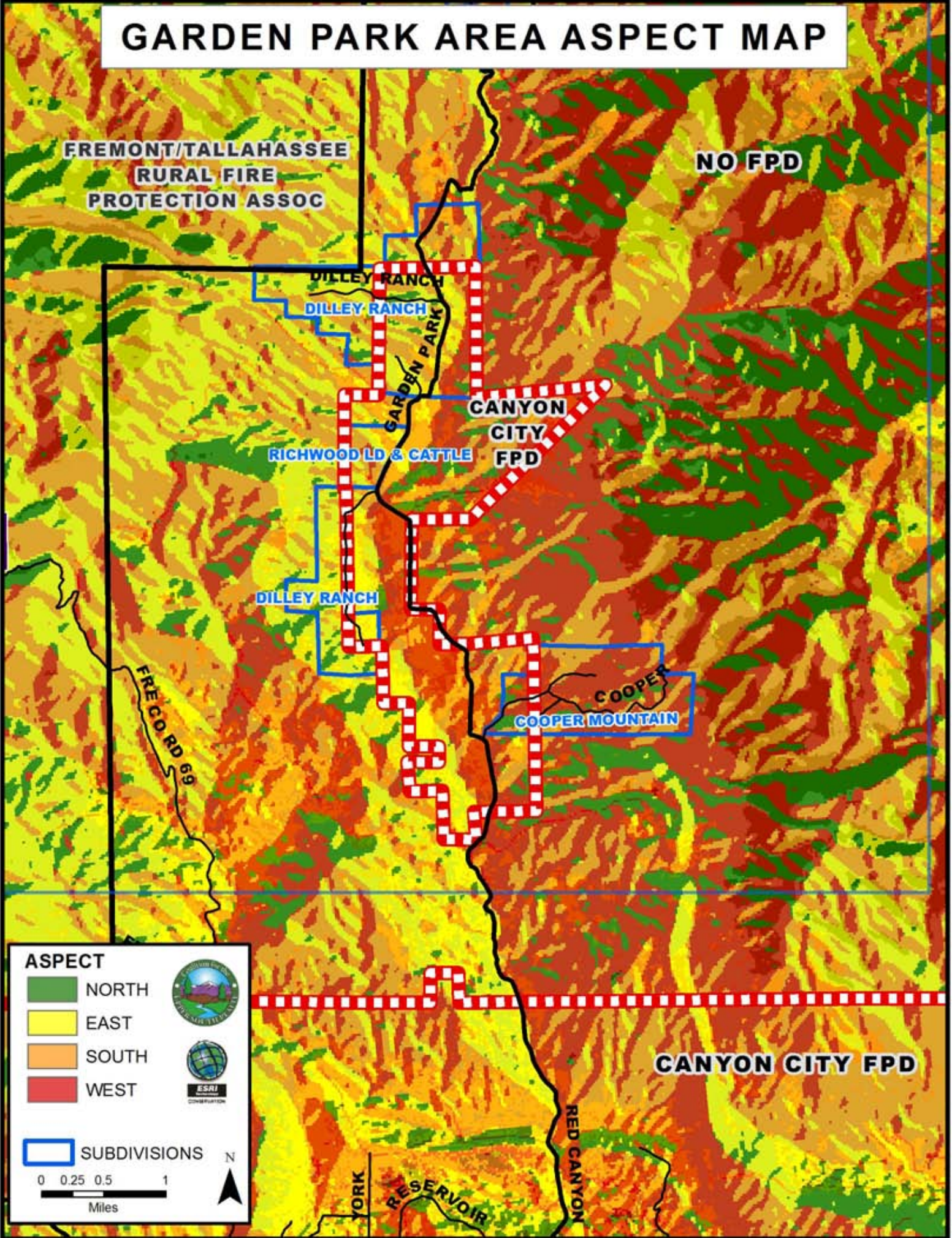

## ASPECT

- NORTH
- EAST
- SOUTH
- WEST



SUBDIVISIONS

N



Miles

CANYON CITY FPD

YORK

RESERVOIR

RED CANYON

# GARDEN PARK AREA ASPECT MAP

FREMONT/TALLAHASSEE  
RURAL FIRE  
PROTECTION ASSOC

NO FPD

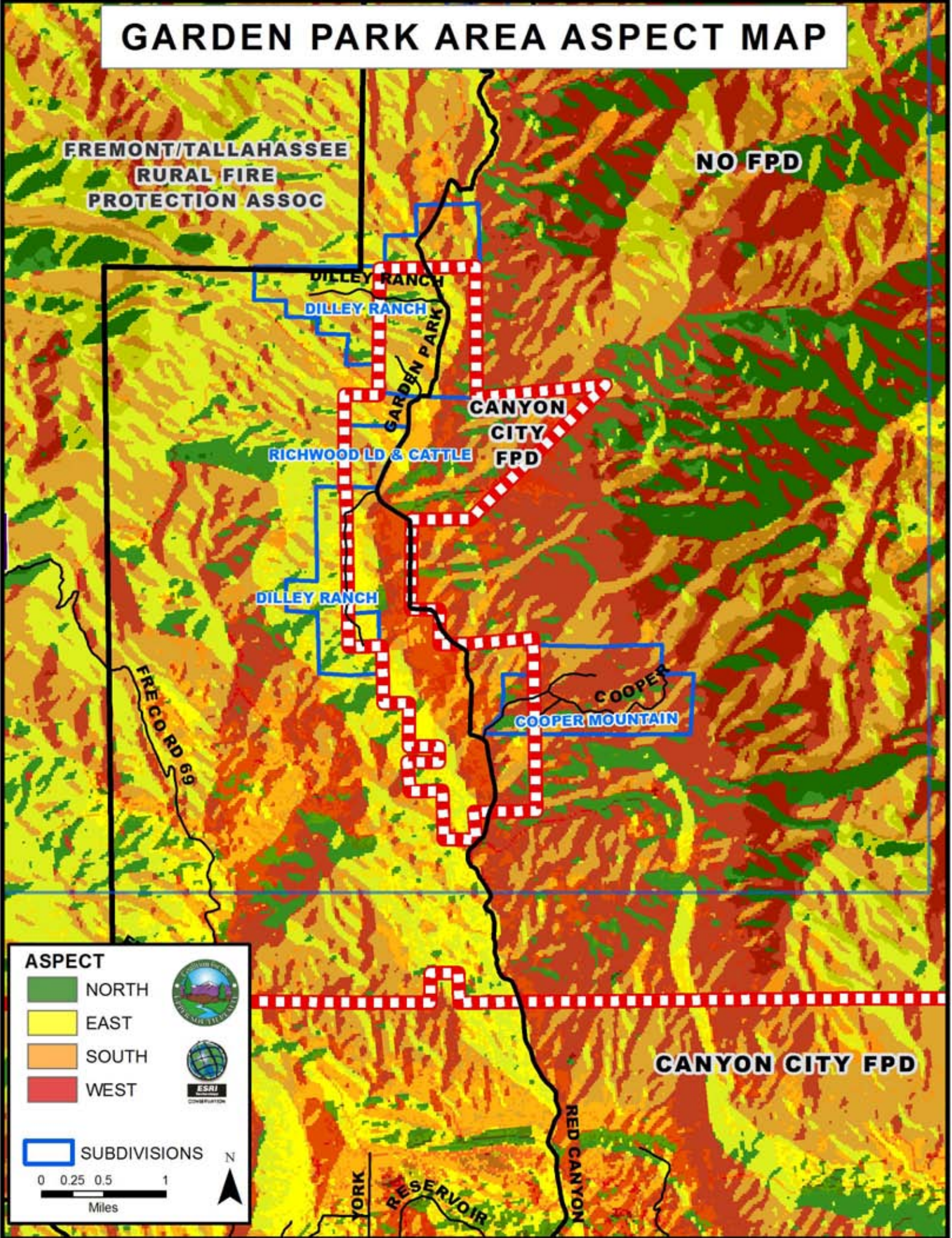

## ASPECT

- NORTH
- EAST
- SOUTH
- WEST



SUBDIVISIONS

N

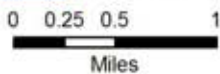

Miles

CANYON CITY FPD

YORK

RESERVOIR

RED CANYON

# GARDEN PARK AREA SLOPE MAP

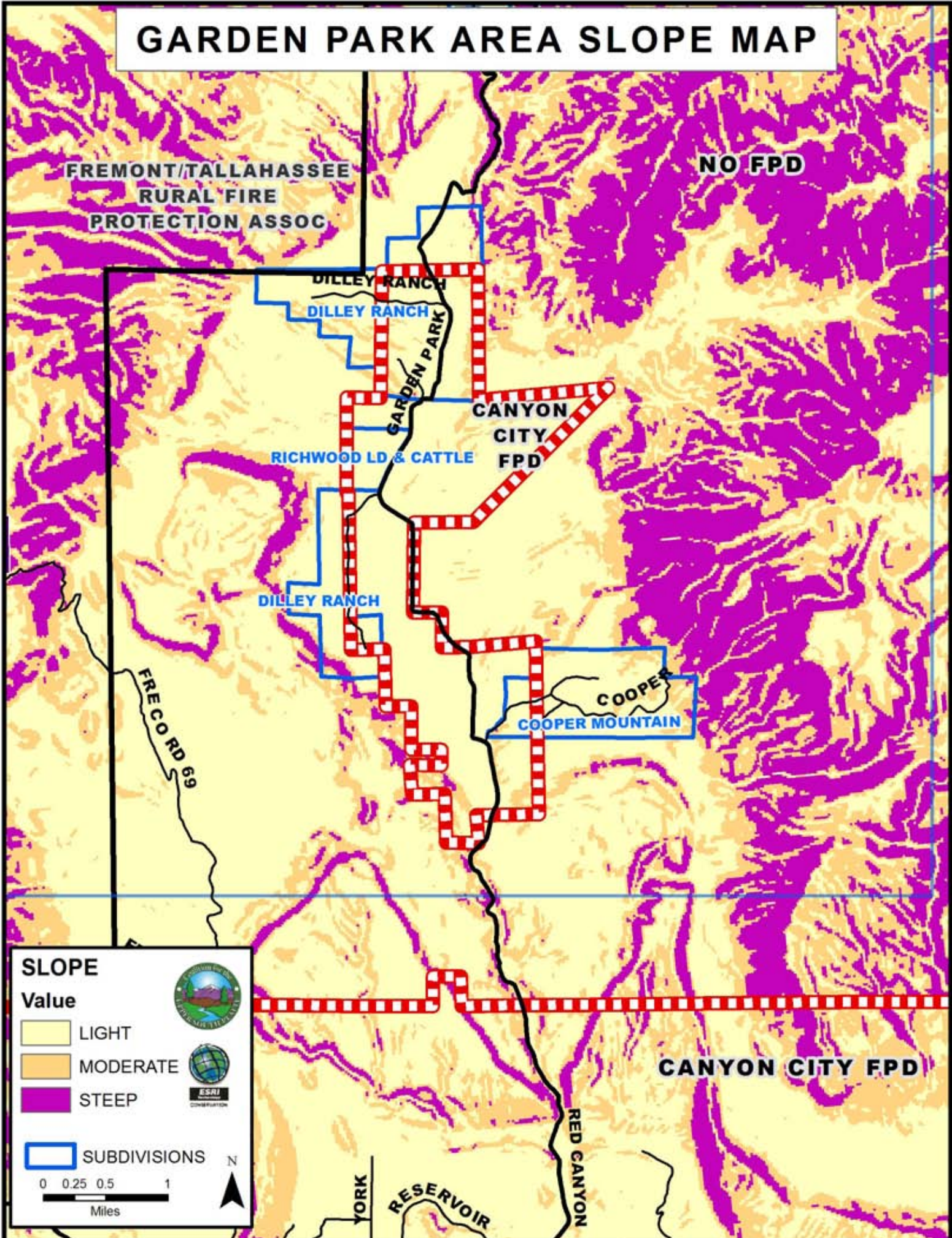

FREMONT/TALLAHASSEE  
RURAL FIRE  
PROTECTION ASSOC

NO FPD

DILLEY RANCH

DILLEY RANCH

GARDEN PARK

CANYON  
CITY  
FPD

RICHWOOD LD & CATTLE

DILLEY RANCH

COOPER

COOPER MOUNTAIN

FRECO RD 69

CANYON CITY FPD

RED CANYON

YORK

RESERVOIR

**SLOPE**  
Value

- LIGHT
- MODERATE
- STEEP

SUBDIVISIONS

0 0.25 0.5 1  
Miles

N

# GARDEN PARK AREA SLOPE MAP

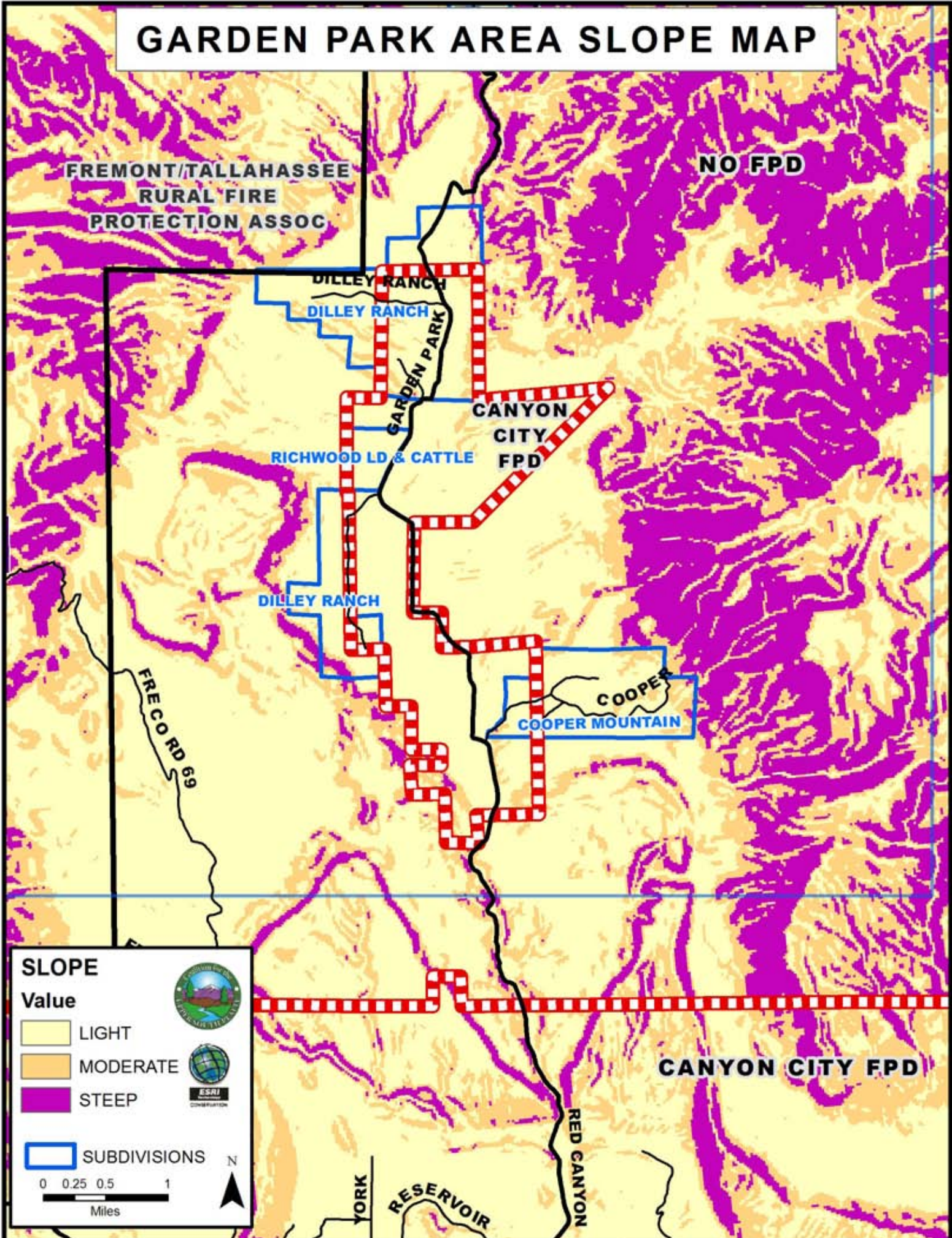

FREMONT/TALLAHASSEE  
RURAL FIRE  
PROTECTION ASSOC

NO FPD

DILLEY RANCH

DILLEY RANCH

GARDEN PARK

CANYON  
CITY  
FPD

RICHWOOD LD & CATTLE

DILLEY RANCH

COOPER

COOPER MOUNTAIN

FRECO RD 69

CANYON CITY FPD

YORK

RESERVOIR

RED CANYON

## SLOPE

Value

- LIGHT
- MODERATE
- STEEP

SUBDIVISIONS

N



# GARDEN PARK AREA VEGETATION TYPE MAP

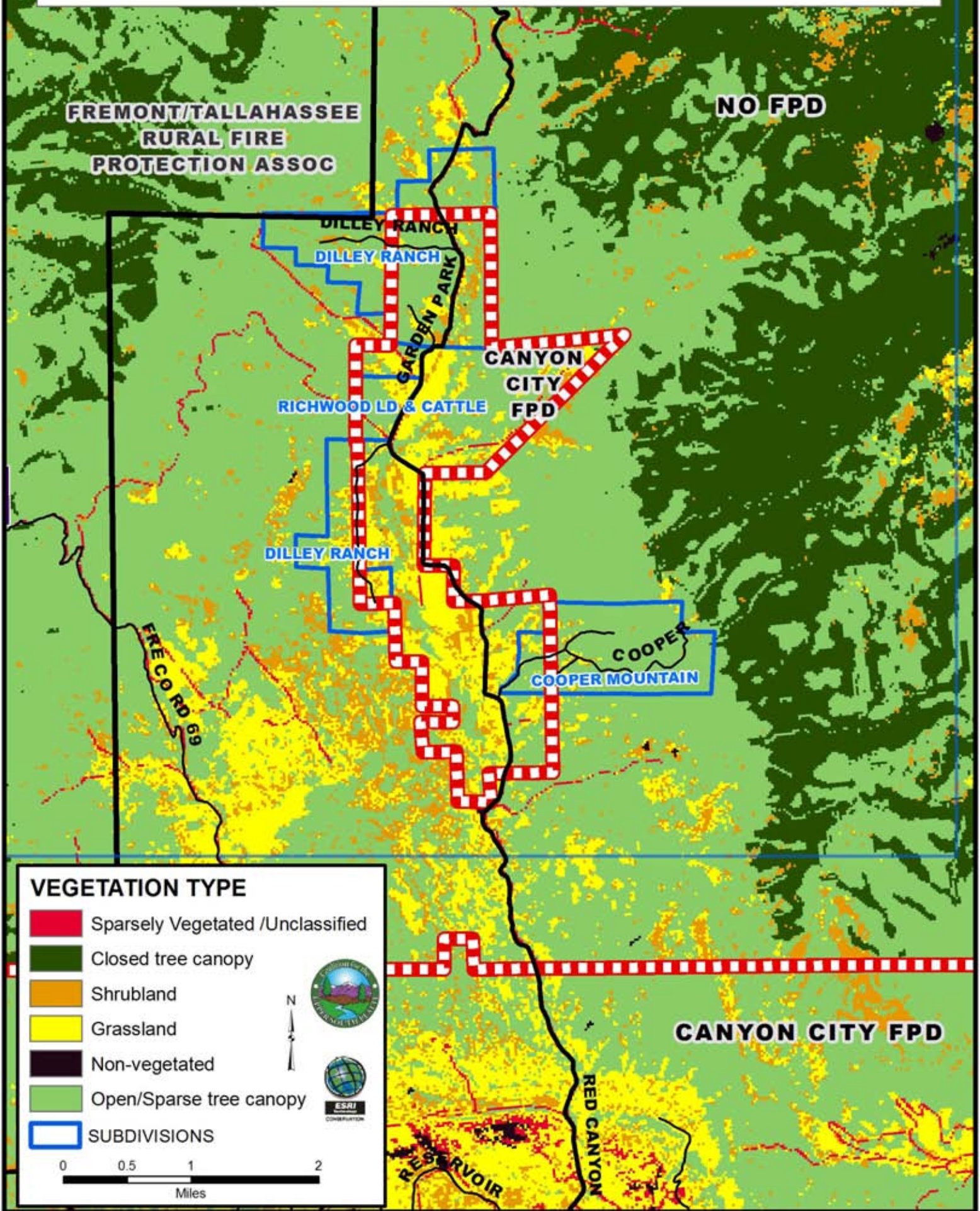

# GARDEN PARK AREA VEGETATION TYPE MAP

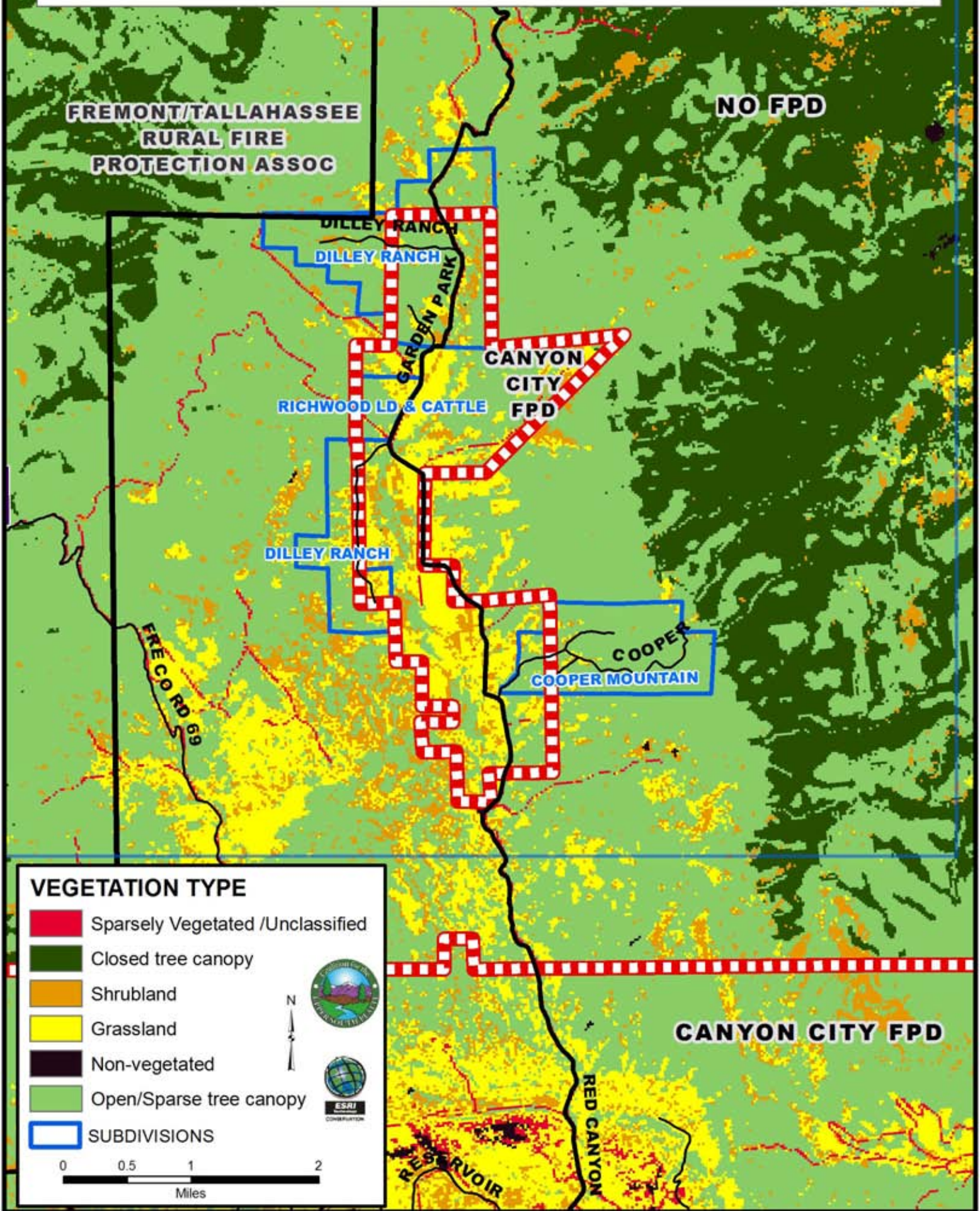



# GARDEN PARK AREA WILDFIRE HAZARD MAP

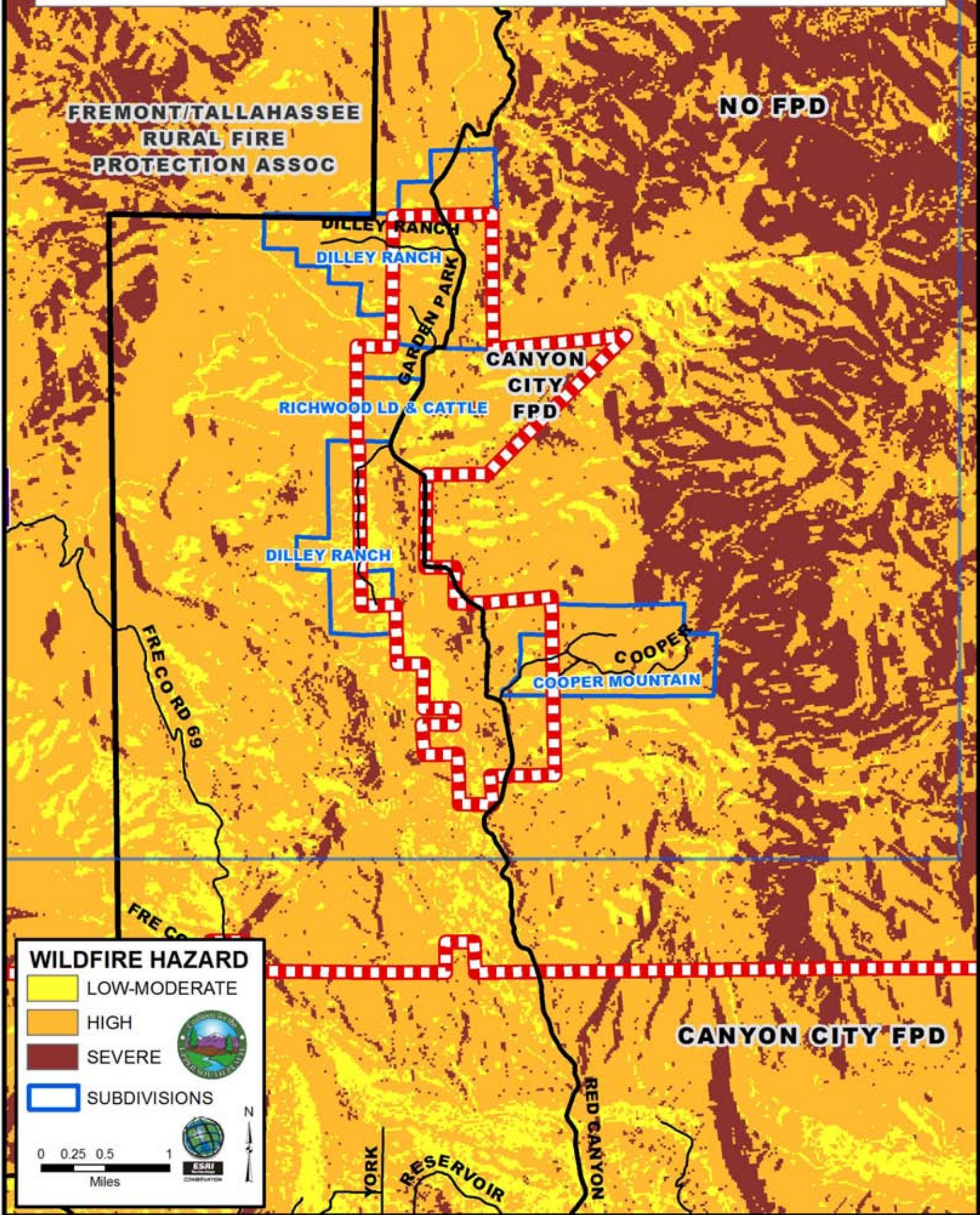

# GARDEN PARK AREA WILDFIRE HAZARD MAP

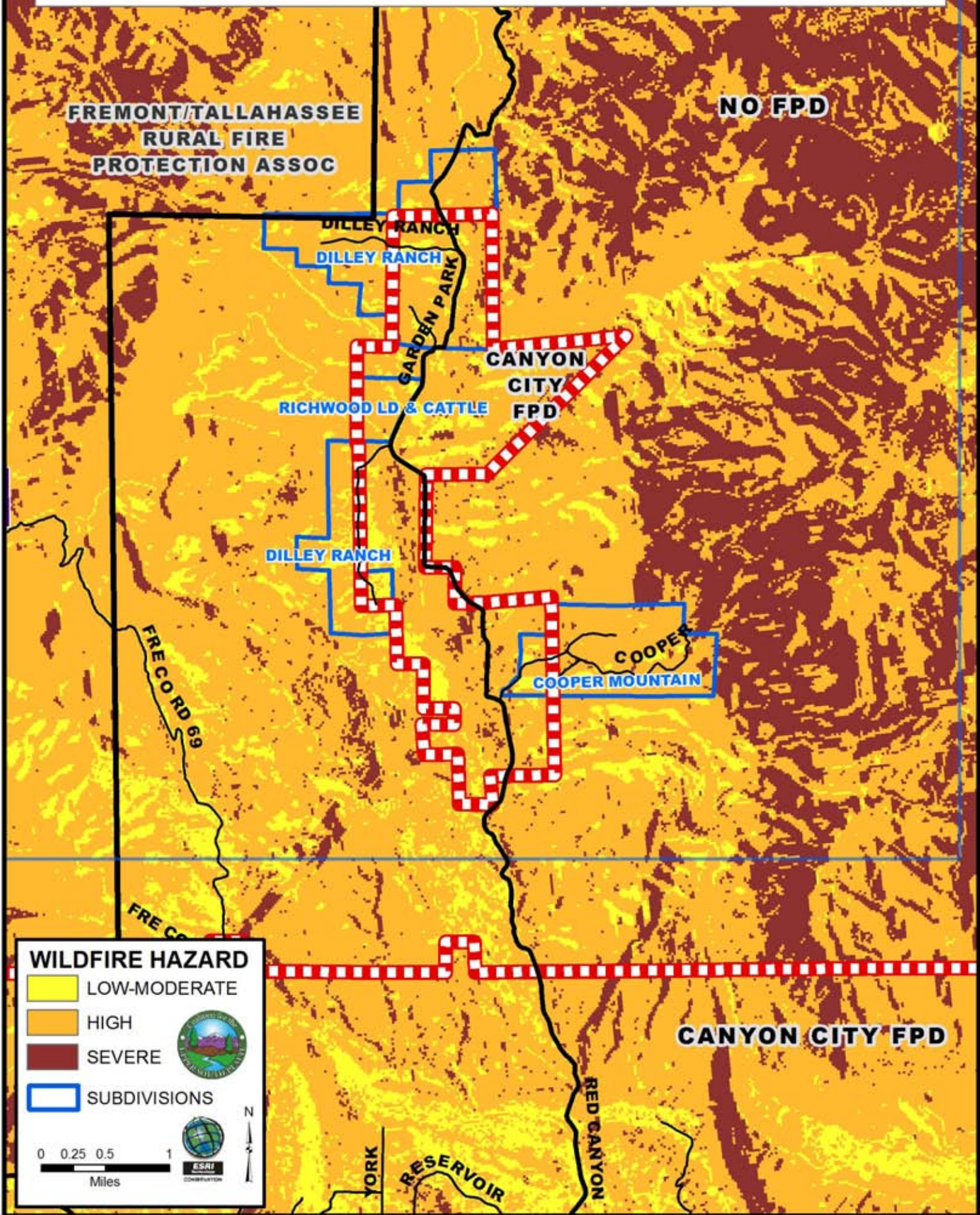

## *Appendix B - Triage & Fire Control Features*

# Garden Park - Fire Control Features

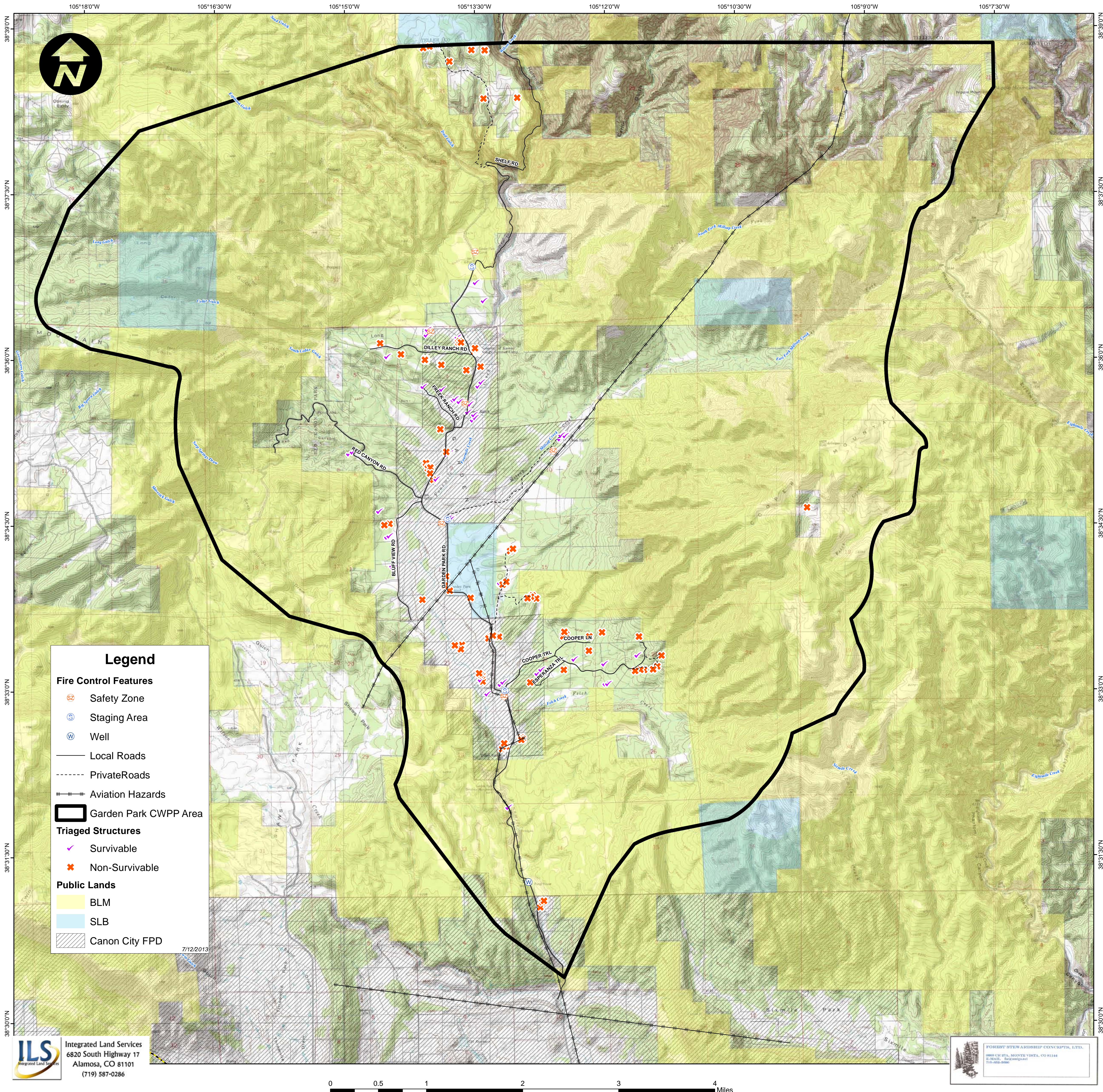

# Garden Park - Fire Control Features

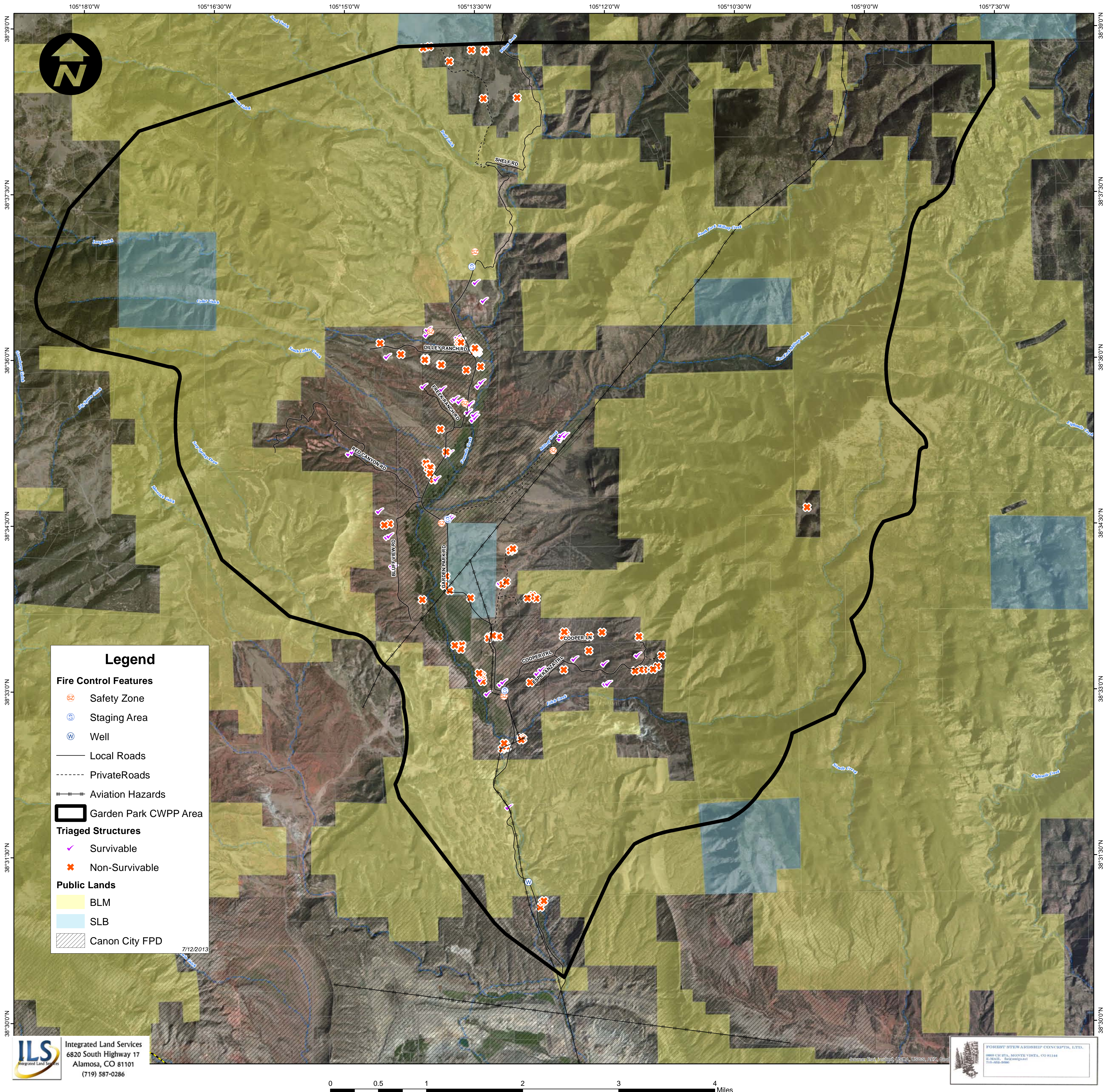

**Legend**

**Fire Control Features**

- SZ Safety Zone
- S Staging Area
- W Well
- Local Roads
- Private Roads
- Aviation Hazards
- Garden Park CWPP Area

**Triaged Structures**

- Survivable
- Non-Survivable

**Public Lands**

- BLM
- SLB
- Canon City FPD

7/12/2013

## APPENDIX C – Evacuation Planning Guidelines

### Background

The growth of urban development in forested wildland areas in recent years has resulted in a potentially hazardous situation. People are attracted to forested areas seeking solitude and to escape the pressures of everyday life. Large land holdings have been subdivided into small, affordable acreages for cabin sites or remote homes. The new generation of small lot landowners value individual trees and have often built their cabins under the cover of or within these overstocked forests. Cabins are constructed on prominent points or ridge tops for the view or they are tucked into the forest canopy seeking solitude. In order to minimize the impact of their presence on the land, driveways are often narrow with inadequate opportunities to turn around at the building site. At the same time, wildfires have been aggressively suppressed allowing dead fuels to accumulate to alarming levels and young trees to establish in high densities. These ladder fuels provide a “leg up” for a wildfire to burn into the tree crowns and move rapidly under windy conditions. Little attention has been paid by landowners to the potential destructive capacity of an uncontrolled wildfire.

In an emergency wildfire situation that threatens the lives and property of residents in the area, the Fremont County sheriff, in consultation with the Canon City FPD, fire suppression teams and land managing agencies, may recommend that residents evacuate to a safe area. Prior evacuation planning is essential to implement this action effectively.

By definition, evacuation is a protective action—moving people from a place of danger to a place of relative safety. It is a temporary mass movement of people that collectively emerges in coping with threats to area residents and visitors.

An Evacuation Plan will facilitate the orderly evacuation during an emergency wildfire situation. Step by step actions provide critical information and guidance for fire suppression and law enforcement personnel during an emergency situation. Each subdivision, home site development area or land owner association should be strongly encouraged to develop an evacuation plan for their area that identifies potential evacuation routes and critical information (locked gates, inadequate bridges, etc) for a variety of wildfire threat scenarios.

Residences of people with mobility issues and special needs, that affect their ability to spontaneously evacuate, should be documented in evacuation plans and highlighted on Fire Control Features maps so appropriate assistance can be provided in a timely manner.

## Critical Contacts

Contact	Phone Number
Fremont County Sheriff	
Fremont County Emergency Management Director	
Colorado State Patrol	
Colorado State Dept. of Public Safety	
Colorado Division of Wildlife	
Colorado State Office of Emergency Services	
Royal Gorge Field Office BLM	
Pueblo Interagency Dispatch Center	
Pike/San Isabel National Forest – San Carlos Ranger District	
Federal Emergency Management Agency	
Local News Media	
Red Cross	
Local Towing Services	

## Check List When Potential for Evacuation Exists

- 1) Close back country roads and trails at trail heads.
- 2) Special needs residents are notified and appropriate measures taken to facilitate their evacuation.
- 3) Post on bulletin boards information regarding fire danger.
- 4) Set up a local Information Center where residents and visitors can access up-to-date information and status regarding wildfires that pose a threat to the area.
- 5) Provide routine updates on wildfire conditions for local radio and television stations as the threat increases.
- 6) When the fire suppression team and land managing agencies (BLM, US Forest Service and Colorado State Forest Service) believe evacuation may become necessary, notify the Fremont County Sheriff and County Office of Emergency Management.
- 7) Fire suppression team and land managing agency managers should meet and coordinate with the Sheriff and County Emergency Management Office to decide if an evacuation is necessary. The decision to evacuate should be made and implemented well before the evacuation needs to be completed. Local conditions and the fire's rate of advance will dictate timing and trigger points.
- 8) The Sheriff, after consultation with the land managing agencies and County Emergency Management Director makes the decision to evacuate the threatened area and implements the actual evacuation.
- 9) Notify residents and visitors of the Order to Evacuate:
  - Siren to alert visitors in the back country Law enforcement patrol vehicles with public address systems announce evacuation order.
  - House-to-house verification that threatened home site developments are completely evacuated.

- Law enforcement vehicles and ATVs drive back country roads and trails to assure evacuation.
  - Use one color flagging to mark secondary roads/trails at their junction with the primary road (evacuation route) when notification is in progress then change to another color when verification is complete on that road/trail.
- 10) Drive evacuation routes installing free standing traffic control signs at key road intersections and opening locked gates or cutting fences to allow exit.
  - 11) CSDPS notify Federal Emergency Management Agency (FEMA)
  - 12) Notify Colorado State Patrol Assign law enforcement to direct traffic at critical road junctions

The officer in charge of the evacuation will make the decision regarding which evacuation route to use at the time. Depending on the situation the decision may be to use any or all of the routes to evacuate the threatened area.

### Emergency Evacuation Routes

Primary emergency evacuation routes are suggested but should be validated with landowners and land management agencies involved prior to the onset of an emergency need for evacuation. These primary evacuation routes should provide multiple opportunities for evacuating traffic to exit the area. Hazardous fuel concentrations should be treated along primary evacuation routes by creating shaded fuelbreaks to reduce canopy cover to 40 percent or less and treat slash and combustible debris within 200 to 300 feet of either side of the road. Tributary roads should be identified in local developments and treated similarly to facilitate a safe and orderly evacuation.

NEIGHBORHOOD	WAYS IN & OUT	ROAD IDENTIFIERS
Cliffside Heights	1	Shelf Road to CR 9 or Cripple Creek
Cooper Mtn.	1	CR 9 – Gold Belt Road
Dilley Park North & South	1	CR 9 – Gold Belt Road
Other Private lands	1	CR 9 – Gold Belt Road
BLM Recreation Sites	1	CR 9 – Gold Belt Road

### Safety Zones

Several Safety Zones are designated in the area. If/When fire behavior precludes exiting Garden Park the Safety Zones should be used in lieu of County Road 9.



## Estimated Time to Implement an Evacuation

The decision to evacuate a threatened area must be made well in advance of the time the fire is expected to threaten residents, visitors and facilities.

## Fire Behavior and Evacuation Timing

Spread Component (SC) is the key fire danger component to monitor. The spread component is a numerical value derived from a mathematical model that integrates the effects of wind and slope with fuel bed and fuel particle properties to compute the forward rate of spread at the head of the fire. Output is in units of feet per minute. A spread Component of 31 indicates a worst-case, forward rate of spread of approximately 31 feet per minute.

The inputs required to calculate the SC are wind, slope, fine fuel moisture (including the effects of green herbaceous plants), and the moisture content of the foliage and twigs of living, woody plants.

Since characteristics through which the fire is burning are so basic in determining the forward rate of spread of the fire front, a unique SC table is required for each fuel type.

When considering spotting, the rich diversity of fuel types scattered throughout Garden Park, and the likelihood of wind, it may be prudent, when fire danger is Very High, to consider starting an evacuation process when fires are burning within 5 miles of down-wind subdivisions or home site development areas (urban interface area). Knowing the SC for the most prevalent fuel type between where the fire is and where the home site developments are can best refine this judgment call. With a SC of 44 a fire will cover 2 miles or more within 4 hours. If the SC is 22 the fire will cover at least one mile within 4 hours and 2 miles within 8 hours. If the SC is 11 the fire will cover two miles within 16 hours. If the SC is 5 the fire can cover two miles within 32 hours.

Remember the lessons of some Colorado fires:

- The Buffalo Creek Fire ran nearly eleven miles in 4.5 hours
- The Hayman Fire ran at least 16 miles in one afternoon

## Timing

Evacuation planning needs to take into account how long it will take to notify residents that an evacuation is necessary, how long it will take for them to get ready and start driving out of the area and then how long it takes to actually drive to a safe area. This determination should be made locally for each development area or subdivision and then validated before it is used during an emergency.

Every situation will be different but it is reasonable to estimate the minimum time required to be no less than 4 hours to complete the process. As much as three hours may be required to notify residents and visitors and get them started moving and another hour to get everyone out of the area. Residents and visitors closest to the advancing threat should be notified first. Once they are driving out of the area it will take them up to an hour in most cases to exit the area if traffic is flowing at a rate of 10 to 20 miles per hour.

Driving time should be measured on each of the potential evacuation routes by driving at a conservative speed depending on road conditions and how many people are expected to be evacuated to approximate

how long it would take to drive the route during an evacuation providing traffic was moving at about that rate. The following table displays the type of information that needs to be incorporated in the Evacuation Plan.

**Travel Time for Evacuation Routes**

Beginning Point	Ending Point	Time Required	Miles Traveled	Average Speed

**GPS Locations for Critical Features and Facilities** – This table provides GPS coordinate locations for critical points referred to.

Feature	GPS Location

**Recommendations**

- Establish and sign Safety Zones in areas where evacuation notification and implementation will be problematic and notify locals as to their location.
- Negotiate agreements with neighboring private land owners and land managing agencies to allow evacuation across their property on their roads and through their locked gates.
- Negotiate an agreement to thin fuels along the evacuation route between the subdivision or home development area and safe areas.
- Upgrade roads on evacuation routes by widening curves, providing water bars to prevent erosion and thinning fuels along these emergency exits.
- Construct and store freestanding “Fire Exit Directional Signs” or “Evacuation Route” for use in marking evacuation routes.
- Develop a specific evacuation procedure and assign responsibilities to County staff.

## Appendix D: Structure Triage

Triage in the community wildfire protection plan context is the determination of priorities for action during a wildfire. The process historically has rated the likelihood that wildfire personnel can safely and successfully defend a structure while it is being threatened by a wildfire.

There is one serious flaw in this approach; it assumes that there will be adequate resources available to take some form of meaningful fire suppression action to defend the structure. When more than one structure is imperiled by a wildfire in a rural setting it is highly unlikely a local volunteer fire department will have sufficient apparatus and personnel to “protect” multiple structures simultaneously. Mutual aid in rural Colorado may take several hours to get to the fire ground.

Assigning a defensible rating to a structure can also lull homeowners into complacency if they think the local fire department will make Herculean efforts to save their home. In most instances the structure will have to survive on its own.

To avoid creating any false impressions about the ability of wildfire suppression personnel to protect every structure regardless the magnitude of the incident, a structure’s chance of surviving a wildfire is rated as probable or not probable. This approach is much more realistic and should encourage property owners to look at their homes in a new light.

Many factors are considered when assigning a survivability rating to a structure. The triage process is highly subjective. Wildfire behavior and structure interactions are not well suited to a clear cut “yes” or “no” analysis. The table below describes criteria used to determine structure survivability. The factors have been extracted from the Wildfire Hazard & Risk Assessment score sheet found in “Living on the Edge” (Troy & Kennedy 2007) and is based on NFPA 1144 standards.

It is important to understand that there are no guarantees a structure with a “probable” survival rating will be standing after an intense wildfire occurs. Similarly occasionally structures with a “not probable” survival assessment may endure a wildfire in spite of all rational analysis.

The survival rating is simply a reliable indicator of a probable outcome following a very dynamic, chaotic, unpredictable event. The rating has been assigned by an individual with over forty years of wildland fire experience considering the criteria below to make the prediction.

Survivability Criteria

PROBABLE	NOT PROBABLE
Vegetation light ~ Anderson fuel models 1 & 2	Vegetation medium to heavy &/or slash. Anderson fuel models 8, 9, 10, 11,
Survivable space >70 feet	Survivable space <71 feet
Slope <20%	Slope >21%
Topographic features minimize fire behavior	Topographic features adversely affect fire behavior
Area not exposed to unusually severe fire weather or strong dry winds	Areas exposed to unusually severe fire weather or strong dry winds
Separated from adjacent structures that can contribute to fire spread	In close proximity to structures that can contribute to fire spread
Class A & B roofing	Class C or non-rated roofing
Non-combustible/fire resistive siding, eaves & deck or combustible deck with no debris underneath	Combustible siding and deck
Building set back from slope appropriate distance	Building close to or overhanging slope
No fire wood and other combustible human plunder in close proximity to structure	Fire wood and other combustible human plunder on deck or within close proximity to structure
Hazardous materials appropriate distance away	Hazardous materials close to structure

Criteria shaded in light yellow automatically drop survivability to Not Probable. Non shaded criteria often influence survivability and cumulatively may predispose a structure to Not Probable survivability status.

*NOTE: You will find that access, escape routes, turnarounds, safety zones and water supply are not factored into the survivability rating. These items are important for firefighter safety but do not influence structure survivability. Remember fire control personnel will most likely not be defending the structure; it will have to go it alone. Safety concerns and limited availability of firefighting resources preclude active intervention to protect structures.*

*Appendix E - FireWise*

# Is Your Home Protected



## From Wildfire Disaster?



A Homeowner's Guide  
to Wildfire Retrofit

# acknowledgments

The staff of the Institute for Business & Home Safety (IBHS) wishes to acknowledge the valuable input of all those involved in the preparation of this booklet. In particular, we extend our thanks to:

**The IBHS Wildfire Committee Members**  
**National Fire Protection Association**  
**State Farm Fire and Casualty Company**  
**National Institute of Standards & Technology**  
**US Geological Survey**  
**Insurance Services Office, Inc.**  
**The Hartford Financial Services Group**  
**California FAIR Plan Association**  
**Allstate Insurance Company**

Architectural Illustrations:  
W. Spaulding, AIA

Photography:  
Cover: Incident scenes; post-burn/damages  
Courtesy National Interagency Fire Center, Boise, Idaho  
Cover and page 1: Bitterroot National Forest, Montana  
Courtesy National Interagency Fire Center, Boise, Idaho  
Cover and page 2: Pine Barrens  
© J Smalley, NJ  
Opposite Table of Contents: Florida Wildfire  
© AP/Wide World Photos

## **Disclaimer**

*The purpose of this document is to provide homeowners with guidance on ways to retrofit and build homes to reduce losses from wildfire damage. It contains suggestions and recommendations based on professional judgment, experience and research and is intended to serve only as a guide. The authors, contributors and publisher disclaim all warranties and guarantees with respect to the information in the document and assume no liability or responsibility with respect to the information.*

---

*“Nature...she pardons no mistakes.”*

*Ralph Waldo Emerson*



© AP/Wide World Photos

*An April 2001 Florida wildfire caused Olga Gutierrez to desperately fight a fire behind her Port Charlotte, FL home with water from her pool.*

In 1993, a wildfire in a dry canyon north of Laguna Beach, California, raced toward hundreds of nearby homes, giving residents little advance warning of its awesome destruction. More than 14,000 acres and 440 homes went up in flames.

In the nearby Mystic Hills neighborhood, 286 homes were totally destroyed. Yet, there was one white house left standing in the midst of hundreds of piles of smoking ash that remained of its neighboring homes. This sole surviving house was built with fire prevention in mind. It stood as an example of how homes can, with a little extra attention, better withstand nature's perils. The practical methods used in and around that house can help reduce the chances of future wildfires from reducing communities to ashes. This guide is designed to make that one rare exception of survival a more common occurrence in the future.



# table of contents

---

<b>Introduction</b> .....	1
<b>Wildfires and Your Home</b> .....	2
The Wildland/Urban Interface Problem.....	2
You and Your Local Fire Department.....	2
Just the Right Conditions.....	3
How Your Home Catches Fire.....	4
Taking Inventory - Is your property at risk? .....	4
What's Your Risk Level? .....	5
What You Can Do to Reduce Your Risk.....	5
<b>Your Home's Landscape</b> .....	7
Creating a Survivable Space.....	7
The Importance of Maintenance.....	7
<b>Your Home's Building Materials and Design</b> .....	8
The Ideal Fire-Resistant Home .....	8
Taking Inventory .....	8
Taking Action.....	9
<b>Helping Your Local Fire Department</b> .....	12
<b>Wildfire Safety Project List</b> .....	13
<b>Wildfire Protection Checklist</b> .....	14
<b>References</b> .....	19
<b>Additional Sources of Information</b> .....	20

---

# Large Fire Locations

## January 1 to October 3, 2000



*Courtesy National Interagency Fire Center  
Boise, Idaho*

# introduction

**N**early every state has been devastated by wildfires in the last century. More than 140,000 wildfires occur on average each year. Since 1990, more than 900 homes have been destroyed each year by wildfires.

So, what can you do to protect yourself, your home and property from wildfires? This guide will help you understand

- why your home is at risk, and
- how you can reduce the risk to your home and property.



*Bitterroot National Forest, Montana  
John McColgan  
FairBanks, AK • August 6, 2000*

# wildfires and your home

## The Wildland/Urban Interface Problem

**W**ildfires occur regularly. Whether started by humans or by lightning, they are part of a natural cycle that helps to maintain the health of our forests. Today, more than ever, people are moving into remote areas, with the desire to "get back to nature," without addressing the dangers that exist around them.

A tremendous wildfire danger exists where homes blend together with the wildland, creating the wildland/urban interface. The addition of homes there interrupts the natural cycle of wildfires. Ultimately,

this contributes to a dangerous build-up of old vegetation, leading to an uncontrollable wildfire.

## You and Your Local Fire Department

In a wildfire, your local fire department has two priorities – to remove you and your family from harm's way and to stop the progression of the wildfire. If your home happens to be in the wildfire's path, they may or may not be able to protect it – there are simply no guarantees.

Consequently, you must take action before a fire starts.



© J Smalley, NJ • Pine Barrens

## Just the Right Conditions

Conditions must be just right for a wildfire to start and spread. Specifically, fuel, weather and topography work together to determine how quickly a wildfire travels and at what intensity.

**Fuels:** The two basic fuel types in the wildland/urban interface are vegetation and structures.

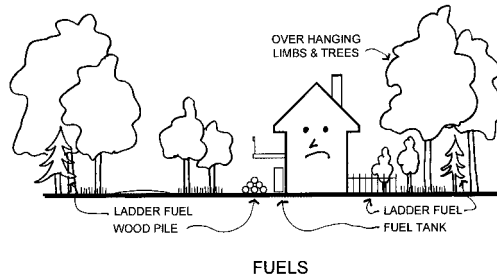

**Vegetation:** Fuel in its natural form consists of living and dead trees, bushes and grasses. Typically, grasses burn more quickly and with less intensity than trees. Any branches or shrubs between 18 inches and 6 feet are considered to be ladder fuels. Ladder fuels help convert a ground fire to a crown fire (tree tops) which moves much more quickly.

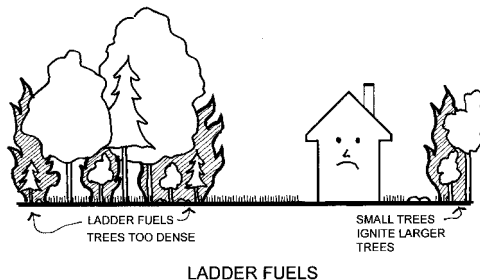

**Structural Density:** The closer the homes are together, the easier it is for the flames to spread from one structure to another.

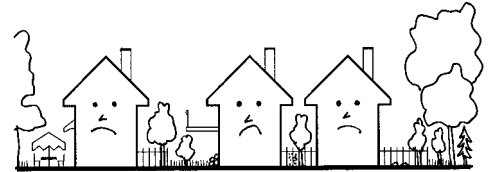

STRUCTURAL DENSITY

**Weather:** High temperatures, low humidity, and swift winds increase the probability of ignitions and difficulty of control. Short and long-term drought further exacerbates the problem.

**Slope:** Slope is the upward or downward incline or slant of terrain. For example, a completely flat plain represents a 0% slope and a hillside that rises 30 feet for every 100 feet horizontal distance represents a 30% slope.

Hot gases rise in front of the fire along the slope face, pre-heating the up-slope vegetation, moving a grass fire up to four times faster with flames twice as long as a fire on level ground.

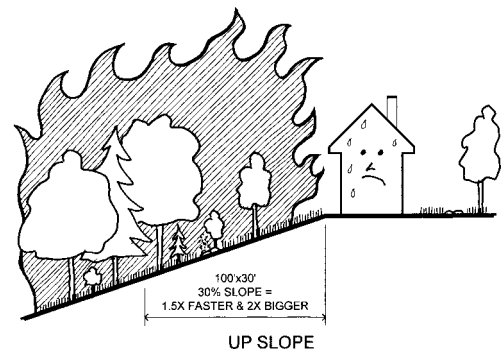

## How Your Home Catches Fire

There are three ways that the wildfire can transfer itself from the natural vegetation or other burning homes to your home – through radiation, convection or firebrands.

**Radiation:** Wildfires can spread to your home by radiating heat in the same way a radiator heats your rooms in the wintertime. Radiated heat is capable of igniting combustible materials from distances of 100 feet or more.

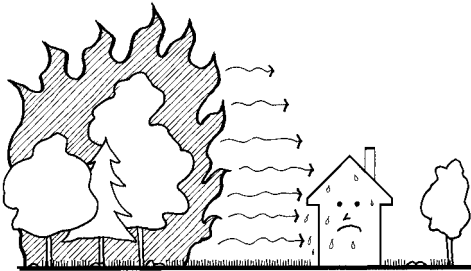

RADIATION

**Convection:** Contact with the convection column (flames) may also cause the wildfire to ignite your house. Typically, the convec-

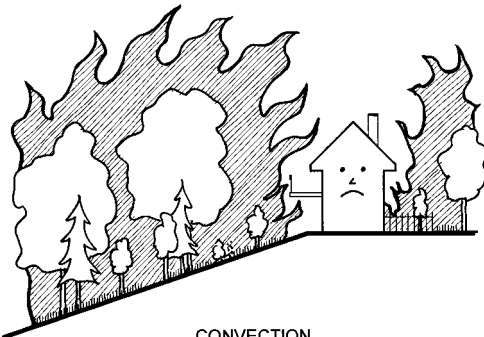

CONVECTION

tive heat column rises vertically, within the smoke plume.

**Firebrands:** Firebrands are burning materials that detach from a fire during strong convection drafts in the burning zone. Firebrands can be carried long distances – more than a mile – by the winds associated with the wildfire.



FIREBRANDS

In all cases, your home's building materials and design play a significant role in establishing the level of exposure that can be endured before ignition from radiation, convection, firebrands or any combination of these three.

## Taking Inventory – Is Your Property at Risk?

The first step in establishing your risk is to assess your property. The table on page 5 lists numerous factors and issues that you should consider.

This assessment will give you a good sense of your property's wildfire risk.

## Assessing Your Property

- |  |  |
|--|--|
| <input type="checkbox"/> Have wildfires occurred in your area? If so, under what conditions?       | <input type="checkbox"/> Is there a substantial amount of tall vegetation crowded in around your home? |
| <input type="checkbox"/> Do you have seasons when wildfires are more likely to occur?              | <input type="checkbox"/> Do tree limbs extend over your home?  |
| <input type="checkbox"/> Do you live in hilly or flat country?                                     | <input type="checkbox"/> Are the trees in good condition or are they dying?                            |
| <input type="checkbox"/> Are there areas around your home that are more susceptible to a wildfire? | <input type="checkbox"/> Do you have a woodpile in close proximity to your home?                       |
| <input type="checkbox"/> Do you border wildland?   | <input type="checkbox"/> Do you have any fuel tanks nearby?  |
| <input type="checkbox"/> Have you used native vegetation in your landscaping?                      | <input type="checkbox"/> Is a wood fence attached to your home?  |

### What's Your Risk Level?

The rough categories that follow on page 6 are not meant to give you an absolute score, but are to help guide you when deciding how to best protect your home.

### What You Can Do To Reduce Your Risk

Homes in a wildland/urban interface area can be designed and maintained to increase the chances of surviving a wildfire without the intervention of the fire department.

This guide will help you protect your home on two different fronts:

- Your Home's Landscape
- Your Home's Building Materials and Design

## Low Risk Areas:

- Little or no history of nearby wildfires
- Humid climate, short dry season
- Flat terrain (no grades greater than 9%)
- Limited wildland
- Home not crowded by trees
- Landscape includes native vegetation
- Manmade fuels at least 50 feet from your home.
- Fire hydrant within 300 feet
- Easy access for fire trucks

## Moderate Risk Areas:

- History of wildfires
- Climate includes a dry season less than 3 months
- Hilly terrain (grades average between 10% and 20%)
- Bordering a wildland with light brush, small trees or grass
- Trees are located in close proximity to your home
- Native vegetation has or has not been incorporated into your landscape
- Manmade fuels are within 50 feet of your home
- Fire hydrant within 500 feet
- Access for fire trucks

## High Risk Areas:

- History of nearby wildfires
- Dry climate with a dry season more than 3 months
- Steep terrain (grades average over 20%)
- Forested wildland within 100 feet of your home
- Native vegetation has not been incorporated into your landscape
- Trees are crowded within 30 feet of your home
- Manmade fuels within 30 feet of your home
- No fire hydrants
- Limited access for fire trucks



# your home's landscape

## Creating a Survivable Space For Your Home

A survivable space is an area of reduced fuels between your home and the untouched wildland. This provides enough distance between the home and a wildfire to ensure that the home can survive without extensive effort from either you or the fire department.

One of the easiest ways to establish a survivable space is to use the zone concept. Zone 1 is the closest to your home and Zones 2 and 3 move progressively further away.

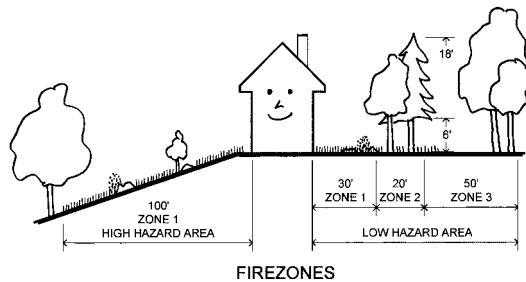

**Zone 1:** Establish a well-irrigated area around your home. In a low hazard area, it should extend a minimum of 30 feet from your home on all sides. As your hazard risk increases, a clearance of between 50 and 100 feet or more may be necessary, especially on any downhill sides of the lot. Plantings should be limited to carefully spaced indigenous species.

**Zone 2** Place low-growing plants, shrubs and carefully spaced trees in this area. Maintain a reduced amount of vegetation. Your irrigation system

should also extend into this area.

Trees should be at least 10 feet apart, and all dead or dying limbs should be trimmed. For trees taller than 18 feet, prune lower branches within six feet of the ground. No tree limbs should come within 10 feet of your home.

**Zone 3:** This furthest zone from your home is a slightly modified natural area. Thin selected trees and remove highly flammable vegetation such as dead or dying trees and shrubs.

So how far should Zones 2 and 3 extend? Well, that depends upon your risk and your property's boundaries.

In a low hazard area, these two zones should extend another 20 feet or so beyond the 30 feet in Zone 1. This creates a modified landscape of over 50 feet total.

In a moderate hazard area, these two zones should extend at least another 50 feet beyond the 50 feet in Zone 1. This would create a modified landscape of over 100 feet total.

In a high hazard area, these two zones should extend at least another 100 feet beyond the 100 feet in Zone 1. This would create a modified landscape of over 200 feet total.

## The Importance of Maintenance

Once you have created your home's survivable space, you must maintain it or risk losing the benefit of its protection.

# your home's building materials and design

**C**reating and maintaining a survivable space is a necessary first step. The next step is to use fire resistant building materials and construction techniques in retrofitting your home.

## The Ideal Fire-Resistant Home

Keep in mind that a wildfire sees your home as just another fuel

source. The survivable space you construct around your home will keep all but the most ferocious wildfires at bay. However, if the wildfire does break through your first line of defense, an ignition might occur on your home's exterior. The ideal situation is for your home's exterior materials to prevent or retard the flames from burning into your interior walls, soffits, attic area, and rooms.

### Taking Inventory

Examine your home's construction and materials. Use the following as a checklist.

- What type of roof covering do you have? Asphalt, wood, concrete, tile or metal?
- How are your eaves, fascias and soffits constructed? Are they made from vinyl, wood or metal?
- What are your home's exterior walls covered with? Are they wood, aluminum or vinyl siding, stucco, brick or concrete masonry?
- Do you have large windows or sliding glass doors that border or face the wildland? Are they single pane, double pane or tempered glass?
- How are your home's attic and sub-floor vents protected? Are their covers metal or vinyl?
- Are spark arresters installed on all your home's chimneys?
- Does your home have a deck or balcony that overhangs a slope?
- Is there a porch, garage or wood fence that attaches directly to your home?

## Taking Action

Now you will need to decide on the best modifications for your home, given your risk.

**Roof:** The roof is the most vulnerable part of your home to wildfires. During a wildfire, firebrands can fall on your roof, landing in your roof's nooks and crannies where a fire can easily start. Once your roof covering does ignite, chances are very good that the rest of your home will follow.

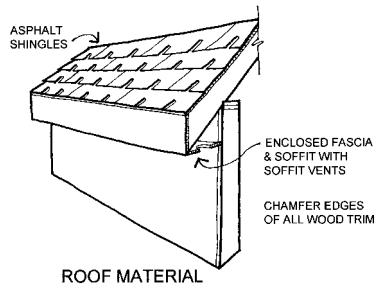
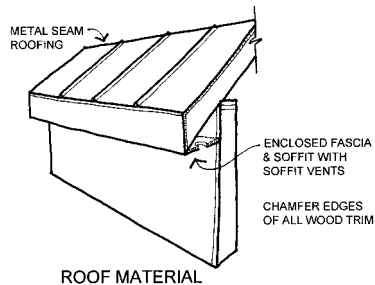

The best way to avoid this situation is to make sure your roof is fire-resistant. The two main fire resistance tests used today include: ASTM E108 and UL 790. There are three levels of classification awarded under the test protocol, A, B, and C, with A being the most

fire resistant. Some treated wood shake shingle products have ratings of Class C or better. Over time, the effectiveness of this chemical is reduced by weathering before the end of the product's useful life and may leave your roof unprotected.

If your roof needs to be re-covered, consider installing a Class A roof covering.

**Exterior Walls:** Exterior walls are susceptible to a wildfire's radiant and convective heat. Although a fire on an exterior wall may not penetrate inside your home, the fire can 'bridge' to more vulnerable areas such as eaves, soffits, vents and windows.

Wall materials that resist heat and flames include cement, plaster, stucco and concrete masonry such as stone, brick or block. Though some materials will not burn, such as vinyl, they may lose their integrity when exposed to high temperature and fall away or melt, providing the fire with a direct path inside the home.

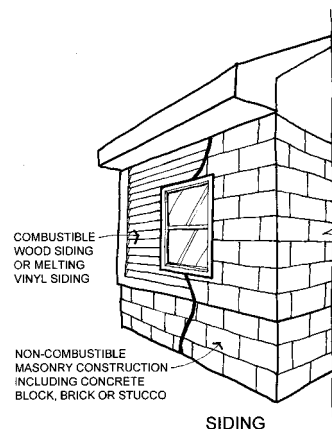

**Exterior Windows, Glass Doors and Skylights:** Exposure to the heat of the wildfire can cause glass to fracture and collapse, leaving an opening for flames and firebrands to enter your home. This applies to both double pane and single pane glass, since double pane glass is only slightly more resistant to heat than single pane glass.

On the other hand, single or double pane tempered glass windows, doors and skylights typically fracture at higher exposures, well above the radiant heat exposures capable of igniting the surrounding wood.

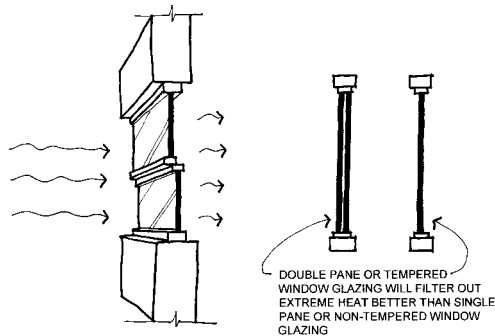

WINDOW GLAZING

**Eaves, Fascias, Soffits:** Eaves, fascias and soffits are vulnerable to both firebrands and convective exposures.

Eaves, fascias and soffits should be ‘boxed’ or enclosed with noncombustible materials to reduce the size of the vents. Materials that melt or

burn in relatively low temperatures, such as PVC and vinyl siding, should not be used, since they do not provide adequate protection and can melt in the heat of the wildfire. Non-combustible screening should be used in the vents.

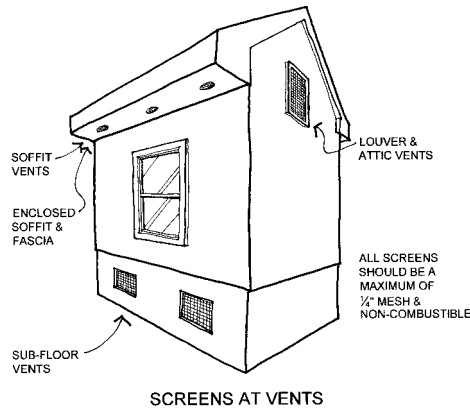

**Attic, Subfloor or Foundation Vents:** Wind and/or direct contact with a fire’s convective heat can push firebrands through the vents into your home’s basement or crawl space.

Your vent openings should be screened to prevent firebrands or other objects larger than 1/4 inch from entering your home. Both your vents and screens should be constructed of materials that will not burn or melt when exposed to radiate or convective heat or firebrands. Also, these vents should be corrosion-resistant to help minimize required maintenance.

**Fireplace Chimneys:** Windblown embers can access your home through your fireplace's chimney flue. Once inside, these firebrands then collect on flammable objects, greatly increasing the chance of combustion. The situation can also be reversed: embers from your own fire can fly out the chimney and start a wildfire, right in your own neighborhood.

The best way to avoid this situation is to install a spark arrestor made from welded wire or woven wire mesh with openings less than 1/4" wide.

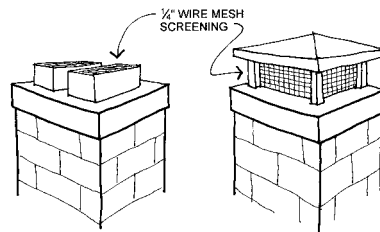

CHIMNEY SCREENS

**Overhangs and Other Attachments:** Overhangs and other attachments include any additional structures attached to a residence such as room pushouts, bay windows, decks, porches, carports and fences. These features are often very vulnerable to convective exposures.

When assessing your home and property, if the feature in question is attached to your home, it should be considered part of your home.

There are a number of ways you can reduce the vulnerability of your home's overhangs and attachments. First and foremost, remove all fuels around these areas. Next, box in the undersides of the overhangs, decks and balconies with noncombustible or fire-resistant materials to reduce the possibility of ignition. For fences, make sure that they don't attach directly to your home.

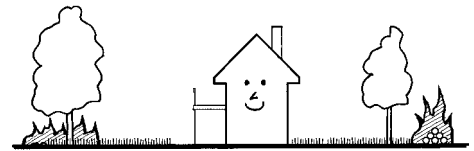

WOOD PILES, DECKS, FENCES, ETC.

# helping your local fire department

**E**ven if you modify your home's landscape to incorporate the most fire-resistant materials and design into your home's construction, there is no guarantee that a wildfire will not threaten your home. It is important that your local fire department be able to find and defend your home.

Here are some suggestions on how to modify your property to accommodate your local fire department.

**Street Signs and Numbers:** If made from combustible materials, your street signs and numbers can ignite or melt, leaving the fire department with no ability to locate your home. It is critical that signs and numbers be noncombustible and visible from the road.

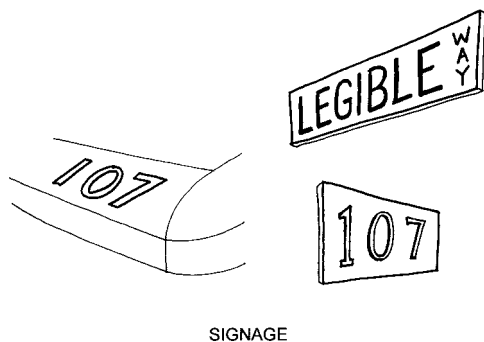

**Driveways:** Fire trucks and equipment are quite large and often have difficulty in tight spots. Consequently, your home's driveway must be large enough to accommodate the typical sized trucks. Fire experts recommend a driveway at least 12 feet wide and 13 feet of vertical clearance.

**Gates:** If your home is gated, it is very important that the gate opens inward and be wide enough to accommodate the fire fighting equipment. Experts also recommend that the gate be at least 30 feet off of the main road, so that the equipment can pull off the road to open the gate. If the gate is locked, the lock should not be so strong that firefighters cannot break it in an emergency.

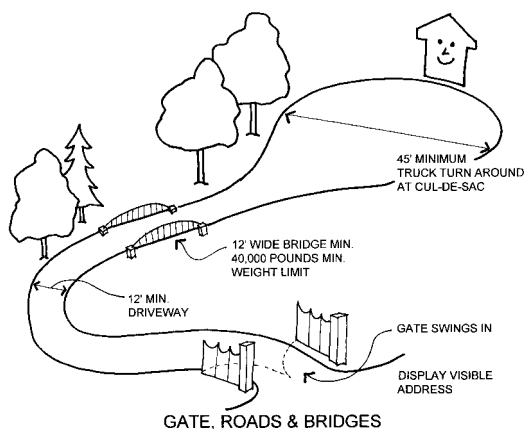

# wildfire safety project list

This list of home improvements is divided into cost categories. You can tackle these projects one at a time, but remember, the more you do, the better protected your home will be against wildfires.

## Category \$ (<\$300)

- Creating a survivable space;
- Maintaining your survivable space;
- Installing fire-resistant signs and address numbers;
- Modifying your attic, sub-floor, and basement vents;
- Installing a spark arrestor on your chimney.

## Category \$\$ (\$300 – \$1000)

- Boxing in overhangs and modifying other attachments;
- Boxing in your eaves, facias, and soffits.

## Category \$\$\$ (>\$1000)







- Re-covering your exterior walls with a more fire-resistant material;
- Replacing single-pane glass windows, doors, or skylights with tempered glass;
- Modifying your driveway, bridges, and gates to accommodate fire trucks.
- Re-roofing your home with a Class A roof covering.

# WILDFIRE PROTECTION CHECKLIST

## Before, During and After: Be Completely Prepared











You will give yourself and your family a better chance of escaping harm during a wildfire by taking as many of the precautions outlined in this brochure as possible. But, these steps are only the beginning. To protect yourself as completely as possible, here are some added suggestions:

### before a wildfire strikes:











	Know where your gas, electric and water main shut-off controls are and how to turn them off if there is a leak or electrical short. Also, know how to use a fire extinguisher. Make sure all adult and teenage members of your family know how to shut off each utility and to use the extinguisher.
	Become familiar with your community's disaster-preparedness plans and create a family plan. Know where the closest police, fire and emergency medical facilities are located.
	Plan several different escape routes from your home and neighborhood and designate an emergency meeting place for the family to reunite. Establish a contact point to communicate with concerned relatives.
	Put together an emergency kit that includes at least a three-day supply of drinking water and food that needs no refrigeration and, generally, no cooking; emergency cooking equipment, if required; a portable NOAA weather radio; first aid supplies and medications; basic tools, such as a wrench, a flashlight and gloves; portable lanterns and batteries; credit cards and cash; and important documents, including insurance policies.
	Talk to your neighbors about wildfire safety. Plan how the neighborhood could work together before, during and after a wildfire. Make a list of your neighbors' skills such as medical or technical. Consider how you would help neighbors who have special needs such as elderly or disabled persons. Make plans to take care of children who may be on their own if parents can't get home.
	Periodically review your homeowner's insurance policy with your insurance agent or company to make sure that, if you are the victim of a disaster, you have enough coverage to rebuild your home and life.







# during a wildfire:

	If you are warned that a wildfire is threatening your area, listen to your portable radio for reports and evacuation information. Follow the instructions of local officials.
	Back your car into the garage or park it in an open space facing the direction of escape. Shut car doors and roll up windows. Leave the key in the ignition or in another easily accessible location.
	Close garage windows and doors, but leave them unlocked. Disconnect automatic garage door openers.
	Confine pets to one room. Make plans to care for your pets in case you must evacuate.
	Arrange temporary housing outside the threatened area.
	When advised to evacuate, do so immediately.
	Wear protective clothing – sturdy shoes, cotton or woolen clothing, long pants, a long-sleeved shirt, gloves and a handkerchief to protect your face.
	Take your emergency kit.
	Lock your home.
	Notify your relatives and the local officials that you have left and where you can be reached.
	Follow the evacuation route that your local officials have identified. If no official route exists, choose a route away from fire hazards. Watch for changes in the speed and direction of the fire and smoke.

If you are SURE you have the time, take additional steps to protect your home:

	Close windows, vents, doors, venetian blinds and heavy drapes. Remove lightweight curtains.
	Shut off gas at the meter. Turn off pilot lights.
	Move flammable furniture into the center of the home away from windows and sliding-glass doors.
	Turn on a light in each room to increase the visibility of your home in heavy smoke.
	Seal attic and ground vents.
	Turn off propane tanks.
	Place combustible patio furniture inside.
	Connect the garden hose to outside taps.
	Place lawn sprinklers on the roof and near aboveground fuel tanks. Wet the roof.
	Wet or remove shrubs within 15 feet of the home.
	Gather fire tools, including a rake, axe, hand/chainsaw, bucket and shovel.

## after a wildfire strikes:

	Listen to and follow the advice and recommendations of the local aid organizations, including the emergency management office, the fire department and the utility companies.
	Check for hazards, such as gas or water leaks and electrical shorts. Turn off damaged utilities. Have the fire department or gas and electric companies turn the utilities back on when the area is secured.
	Check for injuries and administer first aid as needed.
	Check your food and water supplies. Do not eat anything from open containers near shattered glass.

# references

American Society for Testing and Materials. Standard Test Methods for Fire Testing of Roof Coverings ASTM E108. West Conshohocken, PA: ASTM, 2000.

Insurance Services Office, Inc. The Wildland/Urban Fire Hazard. New York, NY: ISO, 1997

International Fire Code Institute Urban-Wildland Interface Code. Whittier, CA: IFCI, 2000

National Fire Protection Association  
Firewise Landscaping Videotapes (3) and Checklist. Firewise Construction Videotapes and Checklist. Quincy, MA: NFPA, 1994

- Protecting Your Home from Wildfire. Quincy, MA: NFPA, 1987

- Standard for Protection of Life and Property from Wildfire NFPA 299. 1997 Edition. Quincy, MA: NFPA, 1997.

NFPA Journal  
Wildland/Urban Interface Fires. Quincy, MA: NFPA, March/April.

National Wildland/Urban Interface Fire Protection Program. Wildland/Urban Interface Fire Hazard Assessment Methodology. Washington, DC: 1997

Underwriters Laboratories  
Tests for Fire Resistance of Roof Covering Materials. UL 790. Northbrook, IL: 1997

Alberta Environment Land and Forest Service  
FireSmart: Protecting Your Community from Wildfire. Partners in Protection. Edmonton, Alberta: May 1999.

# appendix I: additional sources of information

California Department of Forestry and Fire Protection (CDF)

<http://www.fire.ca.gov/>

Colorado State University/Colorado Forestry Service

<http://lamar.colostate.edu/~firewise/>

Firewise

<http://www.firewise.org/>

National Interagency Fire Center (NIFC)

<http://www.nifc.gov/>

U.S. Forest Service

<http://www.fs.fed.us/fire/>

Wildfire News

<http://www.wildfirenews.com/>



**1408 North Westshore Blvd., Suite 208, Tampa, FL 33607**  
**1 (866) 657-IBHS(4247) • Fax (813) 286-9960 • <http://www.ibhs.org/>**

## *Appendix F - Fuelbreak Guidelines*



# Fuelbreak Guidelines for Forested Subdivisions & Communities

By

Frank C. Dennis



*Knowledge to Go Places*



This publication was developed for use by foresters, planners, developers, homeowners' associations and others. Implementation of these measures cannot *guarantee* safety from all wildfires, but will greatly increase the probability of containing them at more manageable levels.



*Inadequate fire planning can result in loss of life or property and costly suppression activities.*



Colorado's forested lands are experiencing severe impacts from continuing population increases and peoples' desire to escape urban pressures. Subdivisions and developments are opening new areas for homesite construction at an alarming rate, especially along the Front Range and around recreational areas such as Dillon, Vail, and Steamboat Springs.

But with development inevitably comes a higher risk of wildfire as well as an ever-increasing potential for loss of life and property. Methods of fire suppression, pre-suppression needs, and homeowner and fire crew safety must all be considered in the planning and review of new developments as well as for the "retrofitting" of existing, older subdivisions.

Fuelbreaks should be considered in fire management planning for subdivisions and developments; however, the following are guidelines **only**. They should be customized to local areas by professional foresters experienced in Rocky Mountain wildfire behavior and suppression tactics.

## Fuelbreak vs Firebreak

Although the term fuelbreak is widely used in Colorado, it is often confused with firebreak. The two are entirely separate, and aesthetically different, forms of forest fuel modification and treatment.

- A firebreak is strip of land, 20 to 30 feet wide (or more), in which all vegetation is removed down to bare, mineral soil each year prior to fire season.

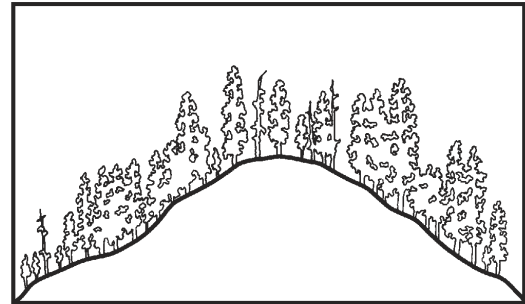

*Above, cross section of mixed conifer stand before fuelbreak modification. Below, after modification.*

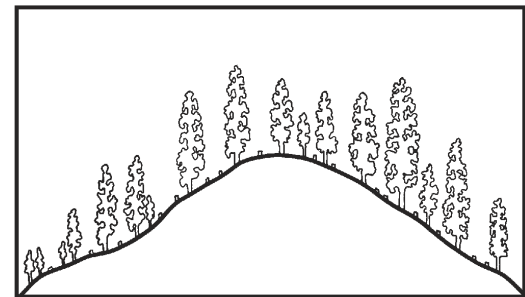

- A fuelbreak (or shaded fuelbreak) is an easily accessible strip of land of varying width (depending on fuel and terrain), in which fuel density is reduced, thus improving fire control opportunities. The stand is thinned, and remaining trees are pruned to remove ladder fuels. Brush, heavy ground fuels, snags, and dead trees are disposed of and an open, park-like appearance is established.

The following is a discussion of the uses, limitations, and specifications of fuelbreaks in wildfire control and fuels management.

## Fuelbreak Limitations

Fuelbreaks provide quick access for wildfire suppression. Control activities can be conducted more safely due to low fuel volumes. Strategically located, they break up large, continuous tracts of dense timber, thus limiting uncontrolled spread of wildfire.

Fuelbreaks can aid firefighters greatly by slowing fire spread under normal burning conditions. However, under extreme conditions, even the best fuelbreaks stand little chance of arresting a large



Before and after photos of a forest stand thinned to reduce fuel loads.

fire, regardless of firefighting efforts. Such fires, in a phenomenon called “spotting,” can drop firebrands 1/8-mile or more ahead of the main fire, causing very rapid fire spread. These types of large fires may continue until there is a major change in weather conditions, topography, or fuel type.

**It is critical to understand: A fuelbreak is the line of defense. The area (including any homes and developments) between it and the fire may remain vulnerable.**

In spite of these somewhat gloomy limitations, fuelbreaks have proven themselves effective in Colorado. During the 1980 Crystal Lakes Subdivision Fire near Fort Collins, crown fires were stopped in areas with fuelbreak thinnings, while other areas of dense lodgepole pine burned completely. A fire at O’Fallon Park in Jefferson County was successfully stopped and controlled at a fuelbreak. The Buffalo Creek Fire in Jefferson County (1996) and the High Meadow Fire in Park and Jefferson Counties (2000) slowed dramatically wherever intense forest thinnings had been completed. During the 2002 Hayman Fire, Denver Water’s entire complex of offices, shops and caretakers’ homes at Cheesman Reservoir were saved by a fuelbreak with no firefighting intervention by a fuelbreak.



Burned area near Cheesman Reservoir as a result of the Hayman Fire. Note the unburned green trees in the middle right of the photo, a treated fuelbreak.

## The Need For A Fuelbreak

Several factors determine the need for fuelbreaks in forested subdivisions, including: (1) potential problem indicators; (2) wildfire hazard areas; (3) slope; (4) topography; (5) crowning potential; and (6) ignition sources.

### Potential Problem Indicator

The table below explains potential problem indicators for various hazards and characteristics common to Colorado’s forest types. All major forest types, except aspen, indicate a high potential for wildfire hazard.

Fuel Type	Characteristics			Hazards			
	Aesthetics	Wildlife	Soil	Wildfire	Avalanche	Flood	Climate
Aspen	2	3	3	2	4	3	2
Douglas-fir	2	2	3	5	2	2	3
Greasewood-Saltbrush	4	2	2	2	1	3	3
Limber-Bristlecone Pine	3	2	4	3	4	2	5
Lodgepole Pine	2	2	3	5	4	2	4
Meadow	5	4	4	2	3	4	3
Mixed Conifer	2	1	1	5	3	1	3
Mountain Grassland	5	3	4	3	3	2	4
Mountain Shrub	3	5	4	4	2	2	3
Piñon-Juniper	2	3	4	4	2	3	2
Ponderosa Pine	2	3	1	5	2	2	3
Sagebrush	4	4	3	3	3	2	3
Spruce-Fir	2	3	3	4	5	3	4

Legend: 5 – Problem may be crucial; 4 – Problem very likely; 3 – Exercise caution; 2 – Problem usually limited; 1 – No rating possible

## Wildfire Hazard Maps

The Colorado State Forest Service (CSFS), numerous counties and some National Forests have completed wildfire hazard mapping for many areas within Colorado, particularly along the Front Range. These maps typically consider areas with 30 percent or greater slope; hazardous fuel types; and hazardous topographic features such as fire chimneys. Wildfire Hazard Ratings may be depicted in several ways. Whatever system is used, areas rated moderate or higher should be considered for fuel modification work.

### Slope

Rate of fire spread increases as the slope of the land increases. Fuels are preheated by the rising smoke column or they may even come into contact with the flames themselves.

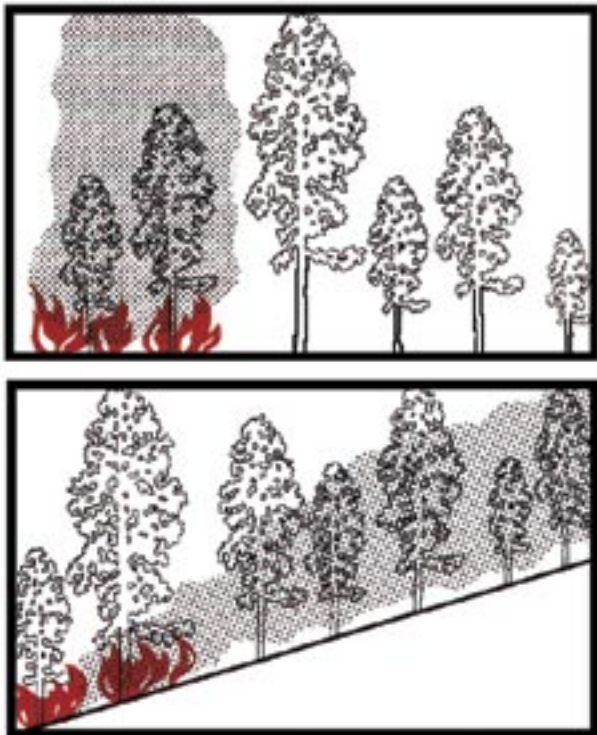

*Fire effects, flat vs steep terrain. Note preheating of fuels on steep ground from passage of smoke column.*

At 30 percent slope, rate of fire spread doubles compared to rates at level ground, drastically reducing firefighting effectiveness. **Areas near 30 percent or greater slopes are critical and must be reviewed carefully.**

### Topography

Certain topographic features influence fire spread and should be evaluated. Included are fire chimneys, saddles, and V-shaped canyons. They are usually recognized by reviewing standard U.S.G.S. quad maps.

- Chimneys are densely vegetated drainages on slopes greater than 30 percent. Wind, as well as air pre-heated by a fire, tends to funnel up these drainages, rapidly spreading fire upslope.

- Saddles are low points along a main ridge or between two high points. Like chimneys, they also funnel winds to create a natural fire path during a fire's uphill run. Saddles act as corridors to spread fire into adjacent valleys or drainages.

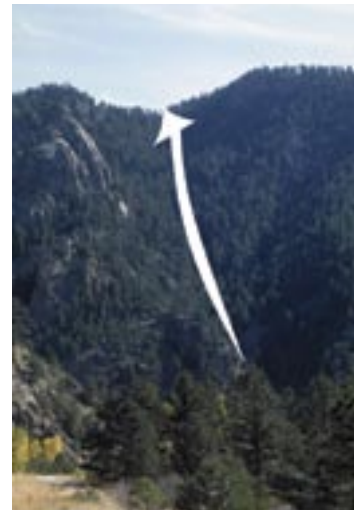

*Chimney.*



*Saddle.*

- Narrow, V-shaped valleys or canyons can ignite easily due to heat radiating from one side to the other. For example, a fire burning on one side of a narrow valley dries and preheats fuels on the opposite side until the fire "flashes over." The natural effect of slope on fire then takes over and fire spreads rapidly up drainage and uphill along both sides of the valley.



*Flashover in V-shaped valley.*

## Crowning Potential

An on-site visit is required to accurately assess crowning potential. A key, below, helps determine this rating. Fuel modification is usually unnecessary if an area has a rating of 3 or less.

### Crowning Potential Key

	Rating
A. Foliage present, trees living or dead — B	
B. Foliage living — C	
C. Leaves deciduous or, if evergreen, usually soft, pliant, and moist; never oily, waxy, or resinous.	0
CC. Leaves evergreen, not as above — D	
D. Foliage resinous, waxy, or oily — E	
E. Foliage dense — F	
F. Ladder fuels plentiful — G	
G. Crown closure > 75 percent	9
GG. Crown closure < 75 percent	7
FF. Ladder fuels sparse or absent — H	
H. Crown closure > 75 percent	7
HH. Crown closure < 75 percent	5
EE. Foliage open — I	
I. Ladder fuel plentiful	4
II. Ladder fuel sparse or absent	2
DD. Foliage not resinous, waxy, or oily — J	
J. Foliage dense — K	
K. Ladder fuels plentiful — L	
L. Crown closure > 75 percent	7
LL. Crown closure < 75 percent	4
KK. Ladder fuels sparse or absent — M	
M. Crown closure > 75 percent	5
MM. Crown closure < 75 percent	3
JJ. Foliage open — N	
N. Ladder fuels plentiful	3
NN. Ladder fuels sparse or absent	1
BB. Foliage dead	0

The majority of dead trees within the fuelbreak should be removed. Occasionally, large, dead trees (14 inches or larger in diameter at 4 1/2 feet above ground level) may be retained as wildlife trees. If retained, all ladder fuels must be cleared from around the tree's trunk.

### Ignition Sources

Possible ignition sources, which may threaten planned or existing developments, must be investigated thoroughly. Included are other developments and homes, major roads, recreation sites, railroads, and other possible sources. These might be distant from the proposed development,

yet still able to channel fire into the area due to slope, continuous fuels, or other topographic features.

### Fuelbreak Locations

In fire suppression, an effective fire line is connected, or "anchored," to natural or artificial fire barriers. Such anchor points might be rivers, creeks, large rock outcrops, wet meadows, or a less flammable timber type such as aspen. Similarly, properly designed and constructed fuelbreaks take advantage of these same barriers to eliminate "fuel bridges." (Fire often escapes control because of fuel bridges that carry the fire across control lines.)

Since fuelbreaks should normally provide quick, safer access to defensive positions, they are necessarily linked with road systems. Connected with county-specified roads within subdivisions, they provide good access and defensive positions for firefighting equipment and support vehicles. Cut-and fill slopes of roads are an integral part of a fuelbreak as they add to the effective width of modified fuels.

Fuelbreaks without an associated road system, such as those located along strategic ridge lines, are still useful in fire suppression. Here, they are often strengthened and held using aerial retardant drops until fire crews can walk in or be ferried in by helicopter.

Preferably, fuelbreaks are located along ridge tops to help arrest fires at the end of their runs. However, due to homesite locations and resource values, they can also be effective when established at the base of slopes. Mid-slope fuelbreaks are least desirable, but under certain circumstances and with modifications, these too, may be valuable.

Fuelbreaks are located so that the area under management is broken into small, manageable units. Thus, when a wildfire reaches modified fuels, defensive action is more easily taken, helping to keep the fire small. For example, a plan for a subdivision might recommend that fuelbreaks break up continuous forest fuels into units of 10 acres or less. This is an excellent plan, especially if defensible space thinning is completed around homes and structures, and thinning for forest management and forest health are combined with the fuelbreak.

When located along ridge tops, continuous length as well as width are critical elements. Extensive long-range planning is essential in positioning these types of fuelbreaks.

## Aesthetics

Improperly planned fuelbreaks can adversely impact an area's aesthetic qualities. Careful construction is necessary when combining mid-slope fuelbreaks with roads involving excessive cut-and-fill.



*These photos, far- and near- views of the same site, illustrate that forest can be thinned without impacting aesthetics.*

Care must also be taken in areas that are not thinned throughout for fuel hazard reduction. In such cases the fuelbreak visually sticks out like a "sore thumb" due to contrasting thinned and unthinned portions of the forest. (Especially noticeable are those portions of the fuelbreak above road cuts).

These guidelines are designed to minimize aesthetic impacts. However, some situations may require extensive thinning and, thus, result in a major visual change to an area. Additional thinning beyond the fuelbreak may be necessary to create an irregular edge and to "feather," or blend, the fuelbreak thinning into the unthinned portions of the forest. Any thinning beyond the fuelbreak improves its effectiveness and is highly recommended.

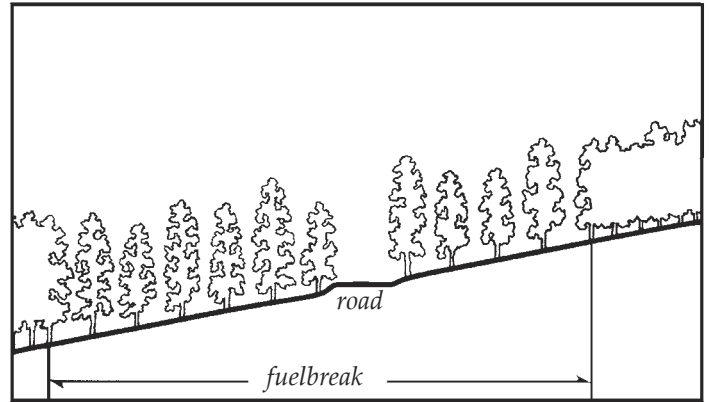

*Cross-section of a typical fuelbreak built in conjunction with a road.*

## Constructing the Fuelbreak

### Fuelbreak Width and Slope Adjustments

Note: Since road systems are so important to fuelbreak construction, the following measurements are from the toe of the fill for downslope distances, and above the edge of the cut for uphill distances.

The minimum recommended fuelbreak width is approximately 300 feet for level ground. Since fire activity intensifies as slope increases, the overall fuelbreak width must also increase. However, to minimize aesthetic impacts and to maximize fire crew safety, the majority of the increases should be made at the bottom of the fuelbreak, below the road cut.

Widths are also increased when severe topographic conditions are encountered. Guidelines for fuelbreak widths on slopes are given below:

Fuelbreak Width/Slope			
Percent Slope (%)	Minimum Uphill Distance (ft)	Minimum Downhill Distance (ft)	Total Width of Modified fuels (ft)*
0	150	150	300
10	140	165	303
20	130	180	310
30	120	195	315
40	110	210	320
50	100	225	325
60	100	240	340

\*As slope increases, total distance for cut-and-fill for road construction rapidly increases, improving fuelbreak effective width.

## Stand Densities

Crown separation is a more critical factor for fuelbreaks than a fixed tree density level. A *minimum* 10-foot spacing between the edges of tree crowns is recommended on level ground. As slope increases, crown spacing should also increase. However, small, isolated groups of trees may be retained for visual diversity. Increase crown spacing around any groups of trees left for aesthetic reasons and to reduce fire intensities and torching potential.

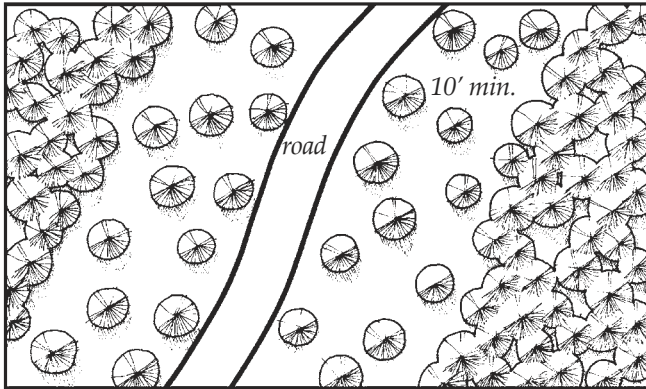

Plan view of fuelbreak showing minimum distance between tree crowns.

In technical terms, a fuelbreak thinning is classified as a heavy “sanitation and improvement cut, from below.” Within fuelbreaks, trees that are suppressed, diseased, deformed, damaged, or of low vigor are removed along with all ladder fuels. Remaining trees are the largest, healthiest, most wind-firm trees from the dominant and co-dominant species of the stand.

Because such a thinning is quite heavy for an initial entry into a stand, prevailing winds, eddy effects, and wind funneling must be carefully evaluated to minimize the possibility of windthrow. It may be necessary to develop the fuelbreak over several years to allow the timber stand to “firm-up” — this especially applies to lodgepole pine and Engelmann spruce stands.

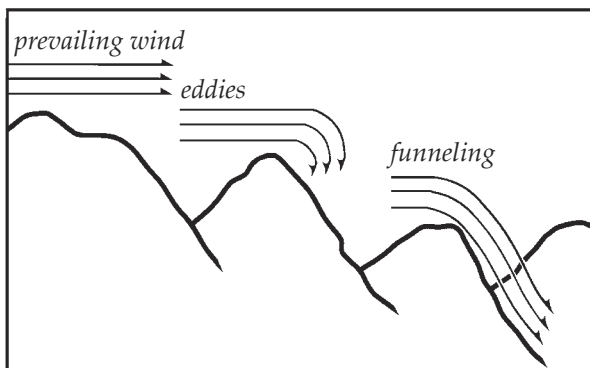

Topography affects wind behavior – an important consideration during fuelbreak construction.

Area-wide forest thinnings are recommended for any subdivisions. Such thinning is not as severe as a fuelbreak thinning, but generally should be completed to fuelbreak specifications along the roads (as outlined on page 6.) In addition, “defensible space thinnings” are highly recommended around all structures (see CSU Coop. Extension Fact sheet 6.302, *Creating Wildfire-Defensible Zones*).

## Debris Removal

Limbs and branches left from thinning (slash) can add significant volumes of fuel to the forest floor, especially in lodgepole pine, mixed-conifer, or spruce/fir timber types. These materials can accumulate and serve as ladder fuels, or can become “jackpots,” increasing the difficulty of defending the fuelbreak during a wildfire. **Slash decomposes very slowly in Colorado and proper disposal is essential.** Proper treatment reduces fire hazard, improves access for humans and livestock, encourages establishment of grasses and other vegetation, and improves aesthetics.

Three treatment methods are commonly used. These are lopping-and-scattering, piling and burning, and chipping. Mulching of small trees and slash using equipment similar to Hydro-axes or Timbcos equipped with mulching heads are becoming a popular method of treatment. Size, amount, and location of slash dictates the method used, in addition to cost and the final desired appearance. The method chosen will also depend on how soon an effective fuelbreak is needed prior to construction in new developments.



Lop and scatter: slash should be no deeper than 12” above ground surface.



*Chipping is the most desirable, but also the most expensive method of slash disposal.*



*Piled slash can be burned but only during certain conditions, such as after a snowfall.*

## Fuelbreak Maintenance

Following initial thinning, trees continue to grow (usually at a faster rate). The increased light on the forest floor encourages heavy grass and brush growth where, in many cases, where little grew before. The site disturbance and exposed mineral soil created during fuelbreak development is a perfect seed bed for new trees that, in turn, create new ladder fuels. Thus, in the absence of maintenance, fuelbreak effectiveness will decrease over time.



*Fuelbreak maintenance is essential. Ingrowth, shown above, will minimize the effectiveness of this fuelbreak within a few years.*

Fuelbreak maintenance problems are most often the result of time and neglect. Misplaced records, lack of follow-up and funding, and apathy caused by a lack of fire events are some of the major obstacles. In addition, the responsibility for fuelbreak maintenance projects is often unclear. For example, control of a fuelbreak completed by a developer passes to a homeowner's association, usually with limited funds and authority to maintain fuelbreaks.

**If fuelbreak maintenance is not planned and completed as scheduled, consider carefully whether the fuelbreak should be constructed. An un-maintained fuelbreak may lead to a false sense of security among residents and fire suppression personnel.**

## Conclusion

An image of well-designed communities for Colorado includes:

- Forested subdivisions where the total forest cover is well-managed through carefully planned, designed, and maintained thinnings. This contributes to reduced wildfire hazards and a much healthier forest — one that is more resistant to insects and disease.
- A system of roads and driveways with their associated fuelbreaks that break up the continuity of the forest cover and fuels. These help keep fires small, while also providing safer locations from which to mount fire suppression activities. In addition to allowing fire personnel in, they will allow residents to evacuate if necessary.
- Individual homes that all have defensible space around them, making them much easier to defend and protect from wildfire, while also protecting the surrounding forest from structure fires.

Creation of such communities is entirely feasible if recognition of the fire risks, a spirit of cooperation, an attitude of shared responsibility, and the political will exists.

*Colorado's mountains comprise diverse slopes, fuel types, aspects, and topographic features. This variety makes it impossible to develop general fuelbreak prescriptions for all locations. **The previous recommendations are guidelines only.** A professional forester with fire suppression expertise should be consulted to "customize" fuelbreaks for particular areas.*

# Appendix G: Fuel Treatment Maps

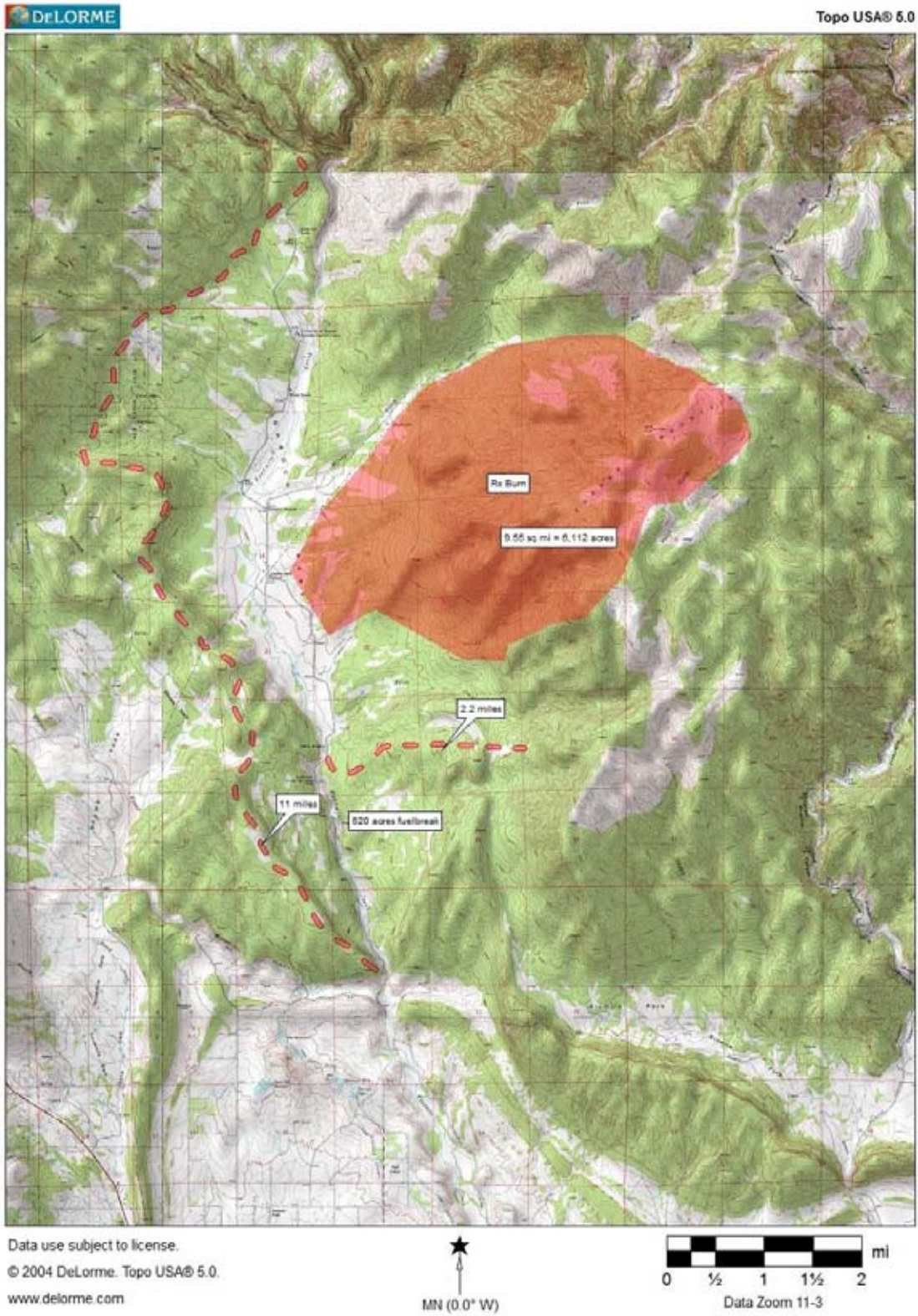



## **APPENDIX H – Road and Driveway Specifications for Emergency Access**

Roads serving one dwelling unit shall meet the following:

- A. Roadway shall be a total of 14' in width, including a 10' all-weather travel surface and 2' shoulders (each side). Curves and turn a rounds should have a minimum of a 30' radius at centerline.
- B. Road grade should generally not be over 7 percent. A maximum grade 10 percent to 12 percent grade would be acceptable for short distances not over 150 feet.
- C. If the driveway is less than 50' the above (A and B) do not apply.
- D. If the length of the road exceeds 150', a turnaround shall meet (template 1 or 2) standards.

Roads serving more than one dwelling shall meet the following:

- A. Roadway shall be a total of 20' in width, including a 16' all weather travel surface and 2' shoulders (template 3) to 16 units, or a total width of 14', including a 10' travel surface, with 2' shoulders on either side and pullouts at 150' intervals in accordance with (template 4).
- B. A total roadway width of 24', including an 18' paved surface and 3' shoulders in accordance with (template 3) for roads serving 16 or more dwellings, or one or more non-residential units.
- C. Grades shall be the same as for one dwelling roads/driveway identified above.
- D. If the length of the driveway is less than 50' then A and B above does not apply.
- E. If the length exceeds 150', a turnaround shall be provided in accordance with (template 1 or 2).

Driveway approaches and private road intersections with public roads shall meet the following:

- A. Driveway approaches and private road intersections with public roads must comply with (template 5).

TEMPLATE 1 - Cul-de-sac

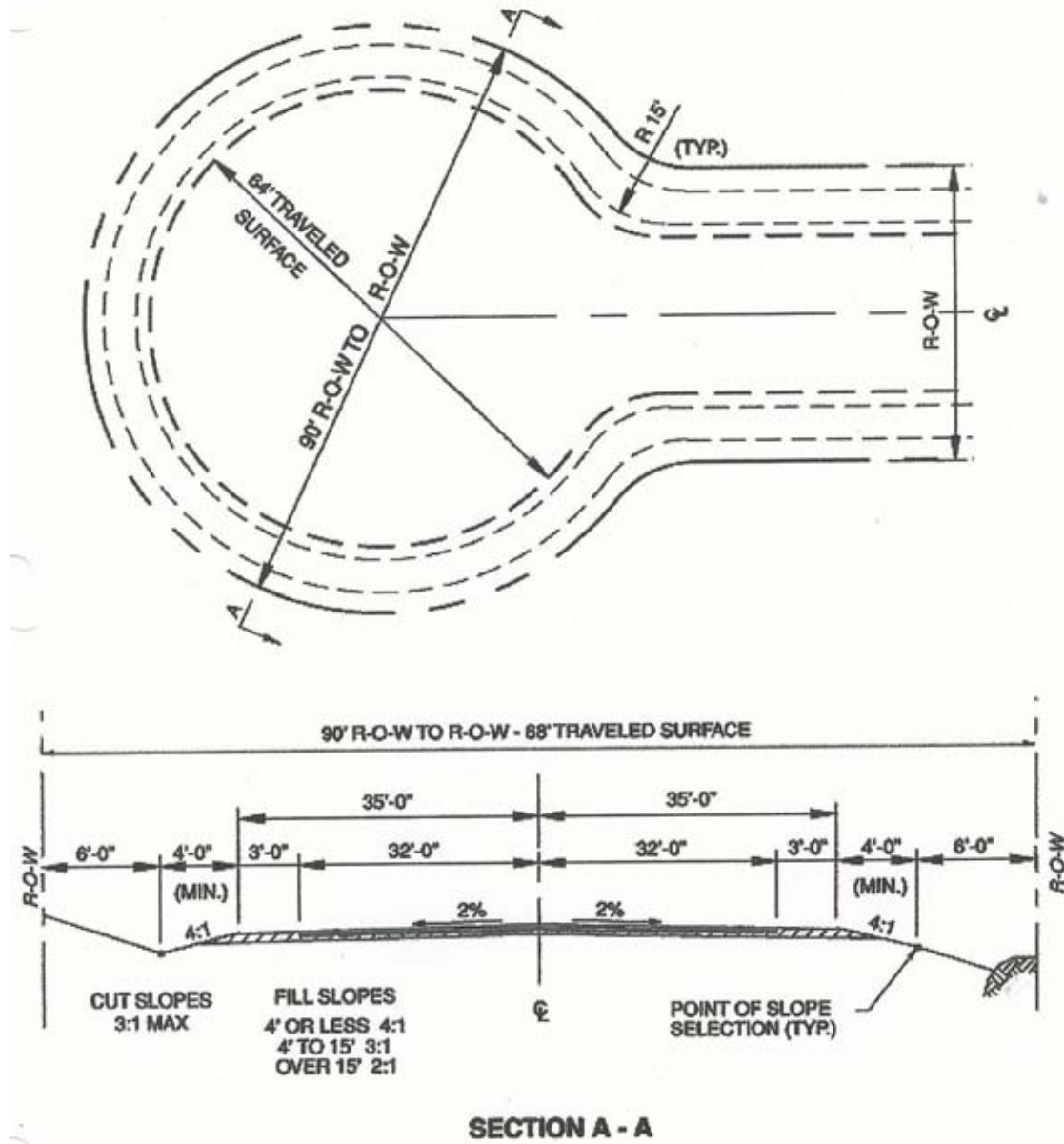

TEMPLATE 2 – Hammerhead Turnaround

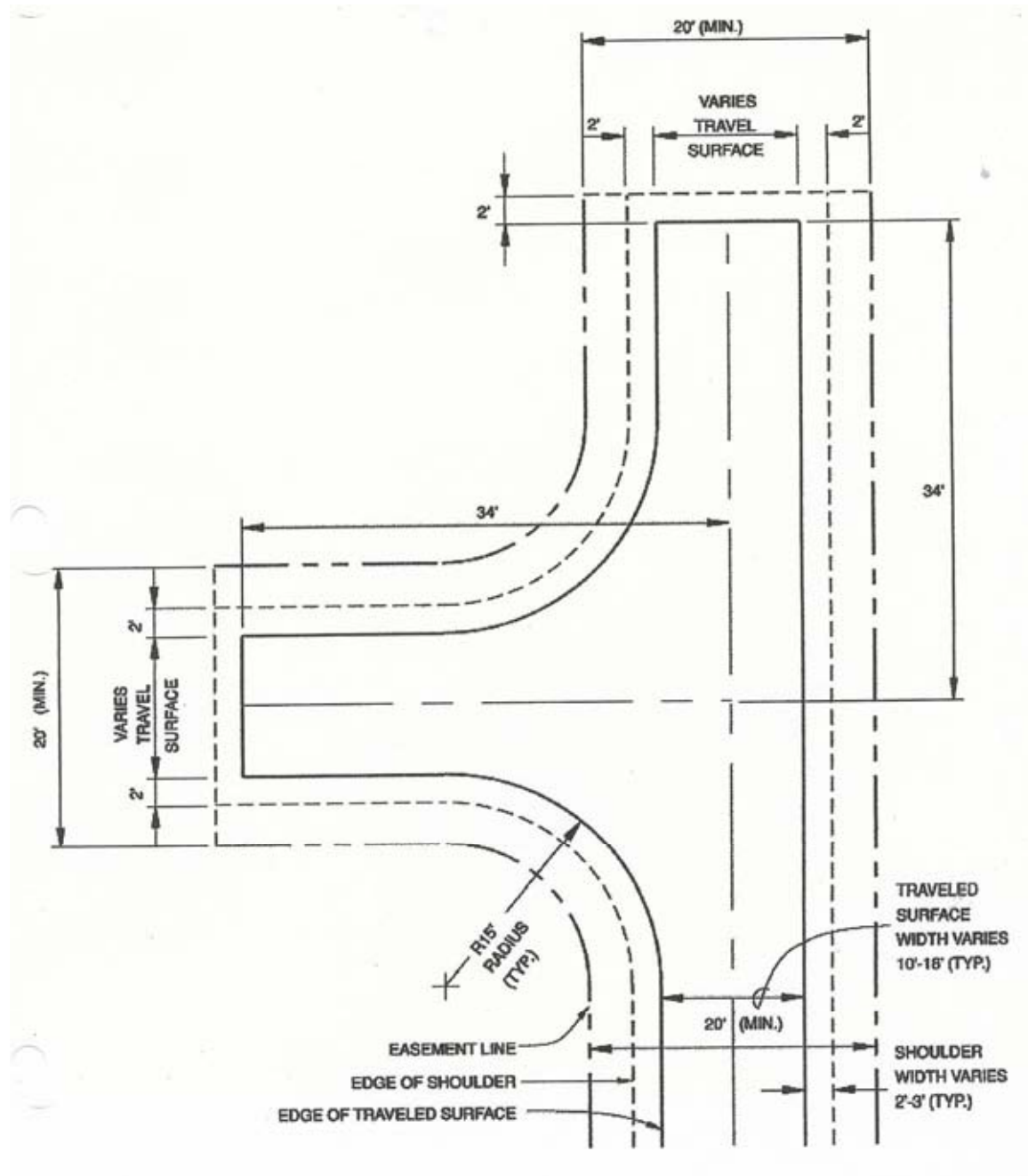

TEMPLATE 3 – Private Road

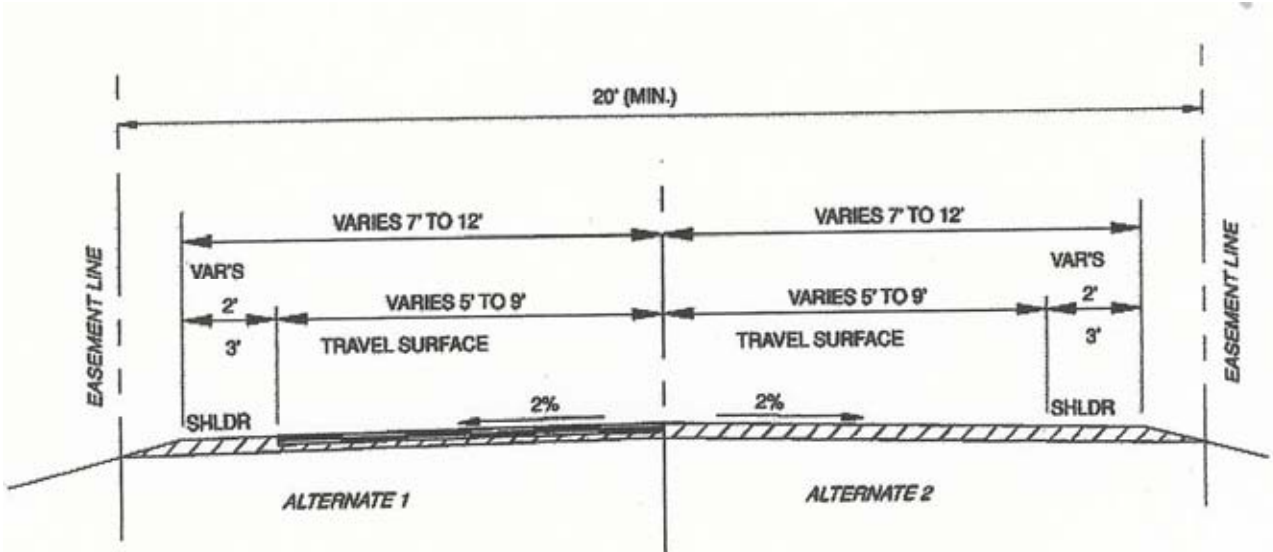

TEMPLATE 4 – Pull Out for Private Road

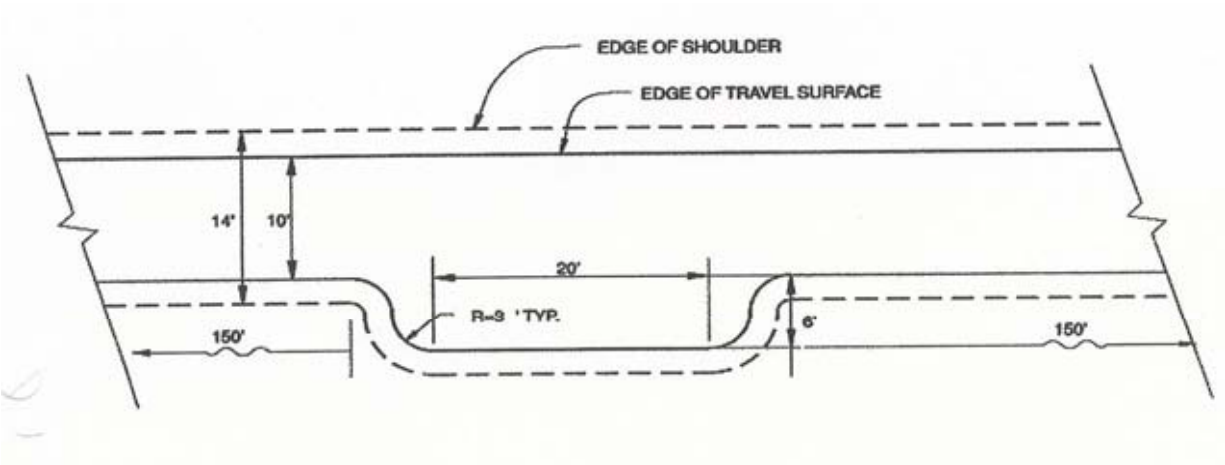



## **APPENDIX I – Definition of Terms**

**Appropriate Management Response (AMR)** - Specific actions taken in response to a wildland fire to implement protection and fire use objectives identified by appropriate government agency. AMR allows for a full range of strategies to be applied, from an intense full suppression response to wildland fire use. The first response decision to be made is whether to have a suppression oriented response or to allow the fire to burn for predetermined benefits.

**Confinement Response-** The suppression-orientated strategy employed in appropriate management response where a fire perimeter is managed by a combination of direct and indirect actions and use of natural topographic features, fuels, and weather factors. These strategies and tactics could include perimeter control.

**Defensible Space-** Area around a structure where fuels and vegetation are treated, cleared or reduced to slow the spread of wildfire towards the structure. It also reduces the chance of a structure fire moving from the building to surrounding forest. Defensible space provides room for firefighters to do their jobs.

**Disturbance-** A discrete event, either natural or human induced, that causes a change in the existing condition of an ecological system.

**Energy Release Component (ERC)** - An index developed through the National Fire Danger Rating System. ERC then is an indicator of dryness in the fuel, is a fuel loading based rate that predicts how much energy f fire will produce both from its consumption of available fuel and through its residence time. ERC, and 1000 hour time lag fuel moisture has been used in dry climates to track seasonal drying trends.

**Escape Fire Situation Analysis (EFSA)** - If a wildfire has escaped initial attack EFSA is the process the agency administrator or acting uses to determine the best suppression strategy for achieving appropriate suppression that best meets resource objectives.

**Fire Management Plan (FMP)** - A strategic plan that defines a program to manage wildland and prescribed fires. The plan could be supplemented by operational plans, prescribed fire plans, hazardous fuels reduction, and prevention plans.

**Fire Use** - The combination of wildland fire use and prescribed fire application to meet specific resource and landowner objectives.

**Fuel Treatment** - Programmed and contracted to reduce or change fuel loading or type on a site. Can be accomplished by mechanical, chemical or fire use.

**Full Response** - A suppression response action that can include: control lines surrounding the entire perimeter, (hot spot and cold trail may be considered completed line) including any spot fires, protection of interior islands, burn-out of fuels adjacent to control lines and mop-up to a standard adequate to hold under high fire intensity conditions. Full response objectives are based on safe yet aggressive approach to achieve containment of the fire by the beginning of the next burn period. Fire behavior may dictate, at least temporarily, the utilization of natural barriers or indirect strategies. These strategies and tactics would include direct control.

**Haines Index** - Lower atmosphere stability index (LASI) developed by Donald Haines. The index relies on two variables: dryness and stability/instability. On a scale of six, three points are given to dryness and three to the stability or instability of the atmosphere. Both these variables have a pronounced affect on extreme fire behavior. In the scaling, a 6 is extreme, 5 are high, 4 are moderate, while 3 to 1 are low.

**Home Ignition Zone** – Includes an area surrounding the home within 100 to 200 feet. The potential for ignition depends on the home’s exterior materials and design and the amount of heat to the home form the flames within the home ignition zone.

**Initial Attack** - An aggressive suppression action consistent with firefighter and public safety and values to be protected.

**Insurance Services Office (ISO) Rating** - An overall fire services rating developed for use in determining insurance premiums for residential and commercial property. Factors such as fire alarm systems, equipment, training, availability of water (hydrants), etc. are used to develop the rating. The rating is on a scale of class 1 to class 10, with 1 providing the best public protection and 10 providing the lowest public protection. See [www.iso.com](http://www.iso.com) for more details.

**Mitigation Actions** - Those on-the-ground activities that will serve to increase the survivability of the structure to check, direct, or delay the spread of fire, and minimize threats to life, property, and resources. Mitigation actions may include mechanical and physical non-fire tasks, specific fire applications, and limited suppression actions. These actions will be used to construct fire lines, reduce excessive fuel concentrations, reduce vertical fuel, and create black lines.

**POL** – Stands for “Products Other than Logs” thinning to harvest poles and posts and firewood.

**Preparedness** - Activities that lead to a safe, efficient, and cost-effective fire management program in support of land and owners management objectives through appropriate planning and coordination.

**Prescribed Fire** - Any fire ignited by management actions to meet specific objectives. A written, approved prescribed fire plan must exist prior to ignition.

**Prescribed Fire Plan** - A plan required for each fire application ignited by management. It must be prepared by qualified personnel and approved by the appropriate agency administrator prior to implementation. Each plan will follow specific direction and must include critical elements and how to mitigate each element.

**Spread Component (SC)** - An index developed through the National Fire Danger Rating System. The index provides predicted rate of spread of a fire (in chains per hour) from inputted information on the fuel complex and weather information collected from a local Remote Automated Weather System (RAWS) site.

**Suppression Constraints** - A limitation placed on suppression forces to minimize adverse affects to the environment due to fire suppression activities. An example would be restricting the use of heavy equipment in certain areas.

**Suppression Oriented Response** - A range of responses to a wildland fire, which range from full response to confinement of the fire. It may also include periodically checking fire status and fire behavior.

**TSI** – Stands for “Timber Stand Improvement” thinning to stimulate growth and improve residual tree health

**Wildfire** - An unwanted wildland fire.

**Wildland Fire** - Any nonstructural fire, other than prescribed fire, that occurs in the wildland. This term encompasses fires previously called both wildfires and prescribed natural fires.





## Appendix J: Potential Sources of Funding

# **The Secure Rural Schools and Community Self-Determination Act of 2000**

## **Frequently Asked Questions**



### **What is the SRS Act? When was it passed?**

The Secure Rural Schools and Community Self-Determination Act of 2000 (SRS Act), Public Law (P.L.) 106-393, was enacted to provide five years of transitional assistance to rural counties affected by the decline in revenue from timber harvests on federal lands. Since 1908, 25-percent of Forest Service revenues, such as those from timber sales, mineral resources and grazing fees, have been returned to states in which national forest lands are located. Set to expire in 2006, the SRS Act was reauthorized and amended several times with the latest changes occurring in October 2008 under P.L. 110-343. Funds have been used for schools and roads and to create employment opportunities, maintain current infrastructure, and improve the watershed and ecosystem health.

### **What does the SRS Act do?**

Originally, the SRS Act altered the county payment program of the U.S. Forest Service from FY2001-FY2006 to allow states or counties to choose whether to receive the average of the three highest payments for FY1986-FY1999 or the regular 25-percent payment. The SRS Act also required that counties receiving at least \$100,000 had to spend 15 percent to 20 percent of those payments for specified county purposes, in accordance with Resource Advisory Committee (RAC) recommendations, or as determined by the Secretary of Agriculture for projects on federal lands. Counties must return unallocated portions to the U.S. Treasury.

Currently, the SRS Act requires counties choose to receive either: 1) a portion of their state's payment or 2) a rolling average of the total receipts for the past seven fiscal years. Counties choosing the first option are bound to that decision until 2011 (4 years); counties selecting the

rolling average may switch after two years. The total amount of available funding declines each fiscal year.

**What does the SRS Act do for Colorado counties?**

Counties that choose the rolling average may spend these funds on projects as they would 25-percent payments. Counties that instead choose a portion of the state’s payment use the funds as described below:

SRS Provision	County selects a portion of the state’s payment		
	<i>Less than \$100,000</i>	<i>Between \$100,000 and \$350,000</i>	<i>More than \$350,000</i>
<i>Title I: Roads and Schools</i>	May spend 100% on Title I projects or may opt to spend 15-20% on Title II and Title III projects.	80-85% spent on this title.	80-85% spent on this title.
<i>Title II: Special Projects / RAC</i>		No more than 15-20% for Title II and Title III projects. May return 15-20% to US Treasury instead.	No more than 15-20% for Title II and Title III projects. Title III projects are capped at 7% of total funds. May return 15-20% to US Treasury instead.
<i>Title III: County Funds</i>			

**What are kinds of projects can be funded by the SRS Act?**

The kinds of projects are limited by what is listed in the SRS Act.

**Title I:** Funds must be used in the same manner as 25-percent funds would normally be spent.

**Title II:** Funds may be used for projects as recommended by Resource Advisory Committees (RAC) and approved by the Secretary of Agriculture or his/her designee (i.e. a forest supervisor or district ranger). Title II funds may be used to make additional investments in, and create additional employment opportunities through, projects that improve the maintenance of existing infrastructure, implement stewardship objectives that enhance forest ecosystems, and restore and improve land health and water quality. Projects shall enjoy broad based support with objectives that may include, but are not limited to:

- Road, trail, and infrastructure maintenance or obliteration;
- Soil productivity improvement;
- Improvements in forest ecosystem health;
- Watershed restoration and maintenance;
- Restoration, maintenance and improvement of wildlife and fish habitat; □ Control of noxious and exotic weeds; and □ Re-establishment of native species.

At least 50 percent of all Title II funds must be used for projects that primarily are dedicated to:

- Road maintenance, decommissioning, or obliteration; or □ Restoration of streams and watersheds.

Title II projects must be recommended by a RAC and must be within the RAC's geographical boundary.

Additional information on Title II projects, RACs, and project planning and approval processes may be found at: [https://www.notes.fs.fed.us/wo/secure\\_rural\\_schools.nsf](https://www.notes.fs.fed.us/wo/secure_rural_schools.nsf).

**Title III:** Funds are used for projects developed and selected by the counties. Project proposals should describe the proposed use of the county funds and must be advertised for 45 days in any publication of local record to allow for public comment. Proposed projects also should be sent to the RAC if one exists in the county.

Funds may **only** be used to:

1. carry out activities under the Firewise Communities Program to provide homeowners in fire-sensitive ecosystems education and assistance with implementation, techniques in home-siting, home construction, and home landscaping that can help protect people and property from wildfires;
2. reimburse the participating county for search and rescue and other emergency services, including firefighting, that are performed on federal land after the date on which the use was approved and paid for by the participating county; and
3. develop Community Wildfire Protection Plans (CWPPs) in coordination with the Secretary of Agriculture.

In FY 2008, Colorado was paid \$14,728,659 for Title I projects and \$1,159,653 for Title III projects. The U.S. Forest Service was holding \$1,316,980 for approved Title II projects.

### **Are these funds the same as the Payments-In-Lieu-of-Taxes (PILT) program?**

No. The PILT program is administered by the U.S. Department of the Interior. These federal payments are made to local governments that help offset losses in property taxes due to nontaxable federal lands within their boundaries. Payments help local governments carry out such vital services as firefighting and police protection, construction of public schools and roads, and search-and-rescue operations. The payments are made annually for tax-exempt federal lands administered by the BLM, National Park Service, U.S. Fish and Wildlife Service (all agencies of the U.S. Department of the Interior), U.S. Forest Service (part of the U.S. Department of Agriculture), and for federal water projects and some military installations. For more information on PILT, please visit: <http://www.doi.gov/pilt>

### **Where can I go for more information?**

If you have questions or need more information on specific projects, contact your US Forest Service district ranger. Contacts for RACs may be found by visiting the following website: [https://wwwnotes.fs.fed.us/wo/secure\\_rural\\_schools.nsf/RAC by County?OpenView&Start=1&Count=1000&Expand=5#5](https://wwwnotes.fs.fed.us/wo/secure_rural_schools.nsf/RAC%20by%20County?OpenView&Start=1&Count=1000&Expand=5#5)

For additional information on the Secure Rural Schools Act, please consult the following references:

Public Law 106-393. 2000. The Secure Rural Schools and Community Self-Determination Act of 2000. Available online at <http://www.blm.gov/or/files/PL106-393.pdf>; last accessed 16 July 2009.

Public Law 110-343. 2008. Reauthorization of the Secure Rural Schools and Community Self-Determination Act of 2000. Available online at <http://www.fs.fed.us/srs/docs/srs-bill-sec-601.pdf>; last accessed 16 July 2009.

USDA. Forest Service. 2009. The Secure Rural Schools and Community Self-Determination Act of 2000. Reauthorization for Fiscal Years 2008—2011. Available online at <http://www.fs.fed.us/srs>; last accessed 16 July 2009.

----. 2008. Reauthorization of the Secure Rural Schools and Community Self-Determination Act of 2000. Available online at <http://www.fs.fed.us/srs/docs/srs-bill-sec-601.pdf>; last accessed 16 July 2009.

US Office of Management and Budget. 2009. Cost principles for state, local, and Indian tribal governments. 2 CFR 225. Available online at <http://ecfr.gpoaccess.gov/cgi/t/text/text-idx?c=ecfr&sid=f3e960da5d4f95af53523ae88cb38ab5&rqn=div5&view=text&node=2:1.1.2.3.6&idno=2>; last accessed 17 July 2009. [Note: This document contains a glossary and instructions that might be useful for local governments that have been awarded federal grant monies.]

Womach, J. 2005. Agriculture: A glossary of terms, programs, and laws. Congressional Research Service. Available online at <http://ncseonline.org/nle/crsreports/05jun/97-905.pdf>; last accessed 16 July 2009.

## **APPENDIX K – References and Publications**

Anderson, Hal E. 1982. Aids to determining fuel Models for Estimating fire Behavior. USDA Forest Service. General Technical Report INT-122, 22 p. Intermountain Forest and Range Experiment Station, Utah, 84401.

Andrews, Patricia; Bevins, Collin; and Seli, Robert. BehavePlus fire modeling system User's Guide. USDA forest Service. General Technical Report RMRS- GTR-106WWW. Rocky Mountain Research Station.

Cohen Jack D. “Wildland-Urban Fire – A Different Approach”

Dennis F.C. 1999. Fire Resistant Landscaping. No. 6.303 Natural Resource Series, Colorado State University Cooperative Extension.

Dennis F.C. 1999. Forest Home fire safety. No. 6.304 Natural Resource Series, Colorado State University Cooperative Extension.

Dennis F.C. 2002. Firewise Plant Materials. No. 6.305 Natural Resource Series, Colorado State University Cooperative Extension.

Dennis F.C. 2003. Creating Wildfire-Defensible Zones. No. 6.302 Natural Resource Series, Colorado State University Cooperative Extension.

Dennis F.C. 2005. Fuelbreak Guidelines for Forested Subdivisions & Communities. Colorado State Forest Service.

Graham, Russell. 2003. Editor. Hayman Fire Case Study: summary. USDA Forest Service. General Technical Report RMRE-GTR-115. Rocky Mountain Research Station.

Helms, John. 1998. The Dictionary of Forestry. Society of American Foresters.  
Troy, Austin & Kennedy, Roger. Editors. 2007 Living on the Edge, Volume 6: Economic, Institutional and Management Perspectives on Wildfire Hazard in the Urban Interface (Advances in the Economics of Environmental Resources). JAI Press - Elsevier

International Urban-Wildland Interface Code. 2003. International Code Council, INC.

Minimum Standards for Delivering Community Wildfire Protection Plans. 2009 Colorado state Forest Service.

NFPA 1144 – Standard for Protection of Life and Property from Wildfire, 2002 Edition

NFPA 295 – Standard for Wildfire Control, 1998 Edition

Preparing a Community Wildfire Protection Plan - A Handbook for Wildland-Urban Interface Communities. 2004. Society of American Foresters, Western Governors' Association et al.

## **Publications**

- Creating Wildfire-Defensible Zones, no 6.302, F.C. Dennis, CSU Cooperative Extension, 5/2003
- Fire Resistant Landscaping, no 6.303, F.C. Dennis, CSU Cooperative Extension, 5/1999
- Forest Home Fire Safety, no 6.304, F.C. Dennis, CSU Cooperative Extension, 5/1999
- FireWise Plant Materials, no 6.305, F.C. Dennis, CSU Cooperative Extension, 11/2003
- Grass Seed Mixes to Reduce Wildfire Hazards, no 6.306, F.C. Dennis, CSU Cooperative Extension, 10/2003
- Vegetative Recovery After Wildfire, no 6.307, R. Moench, CSU Cooperative Extension, 10/2003
- Soil Erosion Control After Wildfire, no 6.308, R. Moench & J. Fusaro, CSU Cooperative Extension, 10/2003
- Insects and Diseases Associated with Forest Fires, no 6.309, D. Leatherman, CSU Cooperative Extension, 12/2002
- Fuelbreak Guidelines for Forested Subdivisions, F. C. Dennis, CSFS/CSU, 2005
- International Urban-Wildland Interface Code. 2003. International Code Council, INC.
- Minimum Standards for Delivering Community Wildfire Protection Plans. 2009 Colorado state Forest Service.
- NFPA 1144 – Standard for Protection of Life and Property from Wildfire, 2002 Edition
- NFPA 295 – Standard for Wildfire Control, 1998 Edition
- Preparing a Community Wildfire Protection Plan - A Handbook for Wildland-Urban Interface Communities. 2004. Society of American Foresters, Western Governors' Association et al.

*Defensible Space - Quick Guide*





## QUICK GUIDE SERIES

FIRE 2012-1

# Protecting Your Home from Wildfire: Creating Wildfire-Defensible Zones

Formerly CSU Extension Factsheet 6.302

If your home is located in the natural vegetation of Colorado's grasslands, shrublands, foothills or mountains, you live in the **wildland-urban interface (WUI)** and are inherently at risk from a wildfire. The WUI is any area where structures and other human developments meet or intermingle with wildland vegetative fuels. In many vegetation types, it is not a matter of *if* a wildfire will impact your home, but *when*.

Wildfires are a natural part of Colorado's varied forest ecosystems. Many rural communities are located in areas historically prone to frequent natural wildfires. Living in the wildland requires more self-reliance than living in urban areas. It may take longer for a fire engine to reach your area, and a small fire department can easily become overwhelmed during an escalating wildfire. Planning ahead and taking actions to reduce fire hazards can increase your safety and help protect your property. As more people choose to live in areas prone to wildfire, additional homes and lives are potentially threatened every year. Firefighters always do their best to protect rural residents, but ultimately, **it is YOUR responsibility to protect your life, family, animals and property from wildfire.**

The information contained in this document is for use by individual landowners to help reduce wildfire risk on their property. In order to effectively protect subdivisions and communities, all landowners must work together

to reduce fire hazards within and adjacent to communities. This includes treating individual home sites and common areas within communities, and creating fuelbreaks within and adjoining the community where feasible. This document will focus on actions individual landowners can take to reduce wildfire hazards on their property. For additional information on broader community protection, go to [www.csfs.colostate.edu](http://www.csfs.colostate.edu).



**Figure 2:** Colorado's grasslands, shrublands, foothills and mountains all have areas in the wildland-urban interface where human development meets wildland vegetative fuels. Photo: CSFS

In this guide, you'll read about steps you can take to protect your property from wildfire. These steps focus on beginning work closest to your house and moving outward. Also, remember that keeping your home safe is not a one-time effort – it requires ongoing maintenance. It may be necessary to perform some actions, such as removing pine needles from gutters and mowing grasses and weeds several times a year, while other actions may only need to be addressed once a year. While



**Figure 1:** Firefighters will do their best to protect homes, but ultimately it is the homeowner's responsibility to plan ahead and take actions to reduce fire hazards around structures. Photo: National Interagency Fire Center

This quick guide was produced by the Colorado State Forest Service to promote knowledge transfer.

October 2012  
[www.csfs.colostate.edu](http://www.csfs.colostate.edu)

you may not be able to accomplish ALL of the actions described in this document to prepare your home for wildfire, each completed activity will increase the safety of your home, and possibly your family, during a wildfire.

*(Note: These guidelines are adapted for ponderosa pine, Douglas-fir and mixed-conifer ecosystems below 9,500 feet. See page 9 for guidelines adapted to other forest ecosystems.)*

This guide primarily will help design your defensible space. **Defensible space** is the natural and landscaped area around a home or other structure that has been modified to reduce fire hazard. Defensible space gives your home a fighting chance against an approaching wildfire. Creating defensible space also reduces the chance of a structure fire spreading to the surrounding forest and other homes.

Three factors determine wildfire behavior: **fuels, weather** and **topography**. We cannot alter weather or topography, so we must concentrate on altering fuels. Fuels include vegetation, such as trees, brush and grass; near homes, fuels also include

such things as propane tanks, wood piles, sheds and even homes themselves. Some plant species are more flammable than others, and the flammability of vegetative fuels changes depending on the season, recent weather events, and other factors such as drought. Fuel continuity and density also play an important role in wildfire.

Wildfire often creates its own weather conditions. Hot rising air and associated winds can carry embers and other burning materials into the atmosphere for long distances, where they can ignite vegetation and structures up to several miles away. Embers have caused the loss of many homes during wildfires.

As you think about protecting your home and property from wildfire, consider how you can manage fuels on your property to prevent fire from spreading to your home and other structures.

For more information on wildfire behavior, please see [FireWise Construction: Site Design and Building Materials](http://www.csfs.colostate.edu) at [www.csfs.colostate.edu](http://www.csfs.colostate.edu).

## Fuel Arrangement and Types

When fuels are abundant, a fire can be uncontrollable and destructive. But when fuels are scarce, a fire cannot build momentum and intensity, which makes it much easier to control and is more likely to be beneficial to the land.

The more dense and continuous the fuels, the bigger the threat they pose to your home. The measure of fuel hazard refers to its continuity, both horizontal and vertical. Horizontal continuity refers to fuels across the ground, while vertical continuity refers to fuels extending from the ground up into the crowns of trees and shrubs. Fuels with a high degree of both vertical and horizontal continuity are the most hazardous, particularly when they occur on slopes. Mitigation of wildfire hazards focuses on breaking up the continuity of horizontal and vertical fuels.

Heavier fuels, such as brush and trees, produce a more intense fire than light fuels, such as grass. However, grass-fueled fires travel much faster than heavy-fueled fires. Some heavier surface fuels, such as logs and wood chips, are potentially hazardous heavy fuels and also should be addressed.



Figure 3: Burning embers can be carried long distances by wind. Embers ignite structures when they land in gaps, crevices and other combustible places around the home. Photo: CSFS

### Remember...

- **Reducing fuels around a home will increase the chances for survival in a wildfire, but there is no guarantee.**
- **This quick guide provides minimum guidelines. The more fuels you remove, the greater the chance your home will survive.**
- **Working with your neighbors and community will increase the effectiveness of your home's defensible space.**

## Vertical/Ladder Fuels

Ladder fuels are defined as smaller trees and brush that provide vertical continuity, which allows a fire to burn from the ground level up into the branches and crowns of larger trees. Lower branches on large trees also can act as ladder fuels. These fuels are potentially very hazardous, but are easy to mitigate. The hazards from ladder fuels near homes are especially important to address. Prune all tree branches from ground level up to a height of 10 feet above ground or up to  $\frac{1}{3}$  the height of the tree, whichever is less. Do not prune further up because it could jeopardize the health of the tree. Shrubs should be pruned based on specifications recommended for the species. Dead branches should be removed whenever possible.

## Surface Fuels

### Logs/Branches/Slash/Wood Chips

Naturally occurring woody material on the ground and debris from cutting down trees (also known as slash) may increase the intensity of fires. Increased fire intensity makes a fire harder to control and increases the likelihood of surface fires transitioning to crown fires. Dispose of any heavy accumulation of logs, branches and slash by chipping, hauling to a disposal site or piling for burning later. Always contact your county sheriff's office or local fire department first for information about burning slash piles. Another alternative is to lop and scatter slash by cutting it into very small pieces and distributing it widely over the ground. If chipping logs and/or slash, it's essential to avoid creating continuous areas of wood chips on the ground. Break up the layer of wood chips by adding nonflammable material, or allow for wide gaps (at least 3 feet) between chip accumulations. Also, avoid heavy accumulation of slash by spreading it closer to the ground to speed decomposition. If desired, two or three small, widely spaced brush piles may be left for wildlife habitat. Locate these well away from your home (NOT in Zones 1 or 2; see page 5-8 for zone descriptions).

### Pine Needles/Duff Layers

Due to decades of fire suppression, decomposing layers of pine needles, twigs and other organic debris—called duff—is deeper under many large trees today than it would have been a century ago. This is especially true in ponderosa pine forests where frequent and naturally occurring fires have been absent. These large trees often are lost when fires occur, because flames burning in the duff layer can pre-heat live vegetation and ignite the trees, or the tree's roots can be damaged from the intense heat of the smoldering duff, killing the tree. It is important to rake needle or duff layers deeper than 2 inches at least 3 feet away from the base of large trees. This should be done annually, and the additional duff also should be removed from the area.

### Grasses

Grasses are perhaps the most pervasive and abundant surface fuel in Colorado. Mow grasses and weeds as often as needed throughout the growing season to keep them shorter than 6 inches. This applies to irrigated lawns and wild or native grasses. This is critical in the fall, when grasses dry out, and in the spring, after the snow is gone but before plants green-up.

Be especially careful when mowing in areas with rocks. Mower blades can hit rocks and create sparks, causing fires in dry grass. Consider mowing only on days with high humidity or after recent moisture to reduce the risk of starting an unwanted fire.

When mowing around trees, be sure to avoid damaging the root system and tree trunk by using a higher blade setting on the mower and trimming grass that grows against the trunk only by hand.

## Crown Fuels

An intense fire burning in surface fuels can transition into the upper portion of the tree canopies and become a crown fire. Crown fires are dangerous because they are very intense and can burn large areas. Crown fire hazard can be reduced by thinning trees to decrease crown fuels, reducing surface fuels under the remaining trees, and eliminating vertical fuel continuity from the surface into the crowns. Specific recommendations are provided in the Defensible Space Management Zones, pages 5-8.



**Figure 4:** Ladder fuels are shrubs and low branches that allow a wildfire to climb from the ground into the tree canopy. Photo: CSFS



**Figure 5:** Surface fuels include logs, branches, wood chips, pine needles, duff and grasses. Photo: CSFS



**Figure 6:** Tree canopies offer fuel for intense crown fires. Photo: Paul Mintier

## The Home Ignition Zone

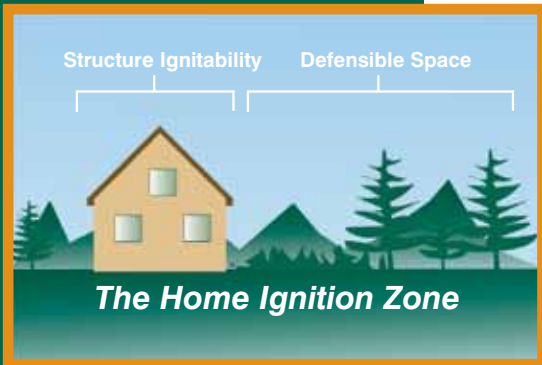

Figure 7: Addressing both components of the Home Ignition Zone will provide the best protection for your home. Credit: CSFS

Two factors have emerged as the primary determinants of a home's ability to survive a wildfire – the quality of the defensible space and a structure's ignitability. Together, these two factors create a concept called the **Home Ignition Zone (HIZ)**, which includes the structure and the space immediately surrounding the structure. To protect a home from wildfire, the primary goal is to reduce or eliminate fuels and ignition sources within the HIZ.

### Structural Ignitability

The ideal time to address home ignition risk is when the structure is in the design phase. However, you can still take steps to reduce ignitability to an existing home.

The **roof** has a significant impact on a structure's ignitability because of its extensive surface area. When your roof needs significant repairs or replacement, use only fire-resistant roofing materials. Also, check with your county building department – some counties now have restrictions against using wood shingles for roof replacement or require specific classifications of roofing material. Wood and shake-shingle roofs are discouraged because they are highly flammable, and are prohibited in some areas of the state. Asphalt shingles, metal sheets and shingles, tile, clay tile, concrete and slate shingles are all recommended roofing materials.

The extension of the roof beyond the exterior structure wall is the eave. This architectural feature is particularly prone to ignition. As fire approaches the building, the exterior wall deflects hot air and gasses up into the eave. If the exterior wall isn't ignition-resistant, this effect is amplified.

Most **decks** are highly combustible. Their shape traps hot gasses, making them the ultimate heat traps. Conventional wooden decks are so combustible that when a wildfire approaches, the deck often ignites before the fire reaches the house.

The **exterior walls** of a home or other structure are affected most by radiant heat from the fire and, if defensible space is not adequate, by direct contact with flames from the fire.

**Windows** are one of the weakest parts of a building with regard to wildfire. They usually fail before the building ignites, providing a direct path for flames and airborne embers to reach the building's interior.

Burning embers are produced when trees and structures are consumed by wildfire. These embers sometimes can travel more than a mile. Flammable horizontal or nearly horizontal surfaces, such as wooden decks or shake-shingle roofs, are especially at risk for ignition from burning embers. Since airborne embers have caused the loss of many homes in the WUI, addressing structural ignitability is critical, even if the area surrounding a home is not conducive to fire spread.

This guide provides only basic information about structural ignitability. For more information on fire-resistant building designs and materials, refer to the CSFS *FireWise Construction: Site Design and Building Materials* publication at [www.csfs.colostate.edu](http://www.csfs.colostate.edu).



Figure 8: (above) Wood shingle roofs are highly flammable and not recommended. Photo: CSFS

Figure 9: (above right) Class A roofing materials including tile, clay, concrete, slate and asphalt shingles are fire-resistant options. Photo: CSFS



Figure 10: Decks, exterior walls and windows are important areas to examine when addressing structure ignitability. Photo: CSFS

# Defensible Space

Defensible space is the area around a home or other structure that has been modified to reduce fire hazard. In this area, natural and manmade fuels are treated, cleared or reduced to slow the spread of wildfire. Creating defensible space also works in the reverse, and reduces the chance of a structure fire spreading to neighboring homes or the surrounding forest. Defensible space gives your home a fighting chance against an approaching wildfire.

Creating an effective defensible space involves a series of management zones in which different treatment techniques are used. Develop these zones around each building on your property, including detached garages, storage buildings, barns and other structures.

The actual design and development of your defensible space depends on several factors: size and shape of building(s), construction materials, slope of the ground, surrounding topography, and sizes and types of vegetation on your property. You may want to request additional guidance from your local Colorado State Forest Service forester, fire department or a consulting forester as you plan a defensible space for your property.

Defensible space provides another important advantage during a fire: increased firefighter safety. Firefighters are trained to protect structures only when the situation is relatively safe for them to do so. They use a process called “structural triage” to determine if it is safe to defend a home from an approaching wildfire. The presence or absence of defensible space around a structure is a significant determining factor used in the structural triage process, as defensible space gives firefighters an opportunity to do their job more safely. In turn, this increases their ability to protect your home.

If firefighters are unable to directly protect your home during a wildfire, having an effective defensible space will still increase your home’s chance of survival. It is important to remember that with wildfire, there are no guarantees. Creating a proper defensible space does not mean that your home is guaranteed to survive a wildfire, but it does significantly improve the odds.

## Defensible Space Management Zones

Three zones need to be addressed when creating defensible space:

**Zone 1** is the area nearest the home and other structures. This zone requires maximum hazard reduction.

**Zone 2** is a transitional area of fuels reduction between Zones 1 and 3.

**Zone 3** is the area farthest from the home. It extends from the edge of Zone 2 to your property boundaries.



Figure 11: Homesite before defensible space. Photo: CSFS



Figure 12: Homesite after creating a defensible space. Photo: CSFS

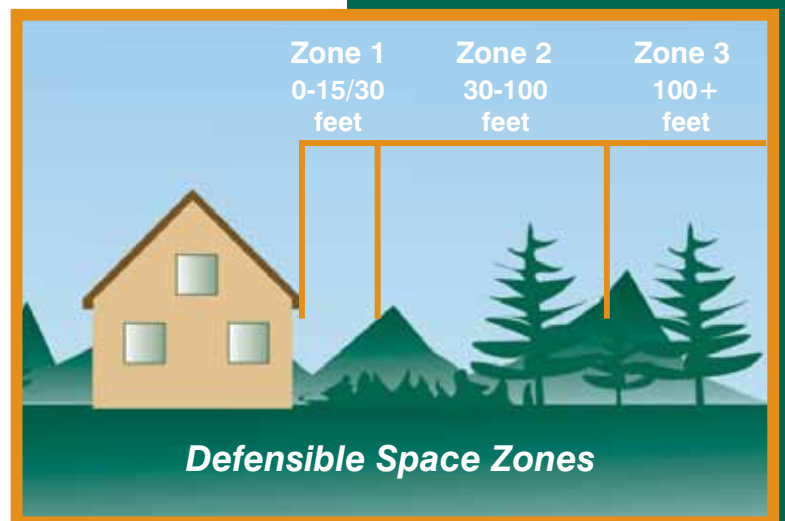

Figure 13: Defensible space management zones. Credit: CSFS

## Zone 1

The width of Zone 1 extends a minimum distance of 15-30 feet outward from a structure, depending on property size. Most flammable vegetation is removed in this zone, with the possible exception of a few low-growing shrubs or fire-resistant plants. Avoid landscaping with common ground junipers, which are highly flammable.

Increasing the width of Zone 1 will increase the structure's survivability. This distance should be increased 5 feet or more in areas downhill from a structure. The distance should be measured from the outside edge of the home's eaves and any attached structures, such as decks. Several specific treatments are recommended within this zone:

- Install nonflammable ground cover and plant nothing within the first 5 feet of the house and deck. This critical step will help prevent flames from coming into direct contact with the structure. This is particularly important if a building is sided with wood, logs or other flammable materials. Decorative rock creates an attractive, easily maintained, nonflammable ground cover.
- If a structure has noncombustible siding (i.e., stucco, synthetic stucco, concrete, stone or brick), widely spaced foundation plantings of low-growing shrubs or other fire-resistant plant materials are acceptable. However, do not plant directly under windows or next to foundation vents, and be sure areas of continuous grass are not adjacent to plantings. Information on fire-resistant plants is available on the CSFS website at [www.csfs.colostate.edu](http://www.csfs.colostate.edu).
- Prune and maintain any plants in Zone 1 to prevent excessive growth. Also, remove all dead branches, stems and leaves within and below the plant.
- Irrigate grass and other vegetation during the growing season. Also, keep wild grasses mowed to a height of 6 inches or less.
- Do not store firewood or other combustible materials anywhere in this zone. Keep firewood at least 30 feet away from structures, and uphill if possible.
- Enclose or screen decks with  $\frac{1}{8}$ -inch or smaller metal mesh screening ( $\frac{1}{16}$ -inch mesh is preferable). Do not use areas under decks for storage.
- Ideally, remove all trees from Zone 1 to reduce fire hazards. The more trees you remove, the safer your home will be.
- If you do keep any trees in this zone, consider them part of the structure and extend the distance of the entire defensible space accordingly.
- Remove any branches that overhang or touch the roof, and remove all fuels within 10 feet of the chimney.
- Remove all pine needles and other debris from the roof, deck and gutters.
- Rake pine needles and other organic debris at least 10 feet away from all decks and structures.
- Remove slash, wood chips and other woody debris from Zone 1.

## Zone 2

Zone 2 is an area of fuels reduction designed to diminish the intensity of a fire approaching your home. The width of Zone 2 depends on the slope of the ground where the structure is built. Typically, the defensible space in Zone 2 should extend at least 100 feet from all structures. If this distance stretches beyond your property lines, try to work with the adjoining property owners to complete an appropriate defensible space.



**Figure 14:** *This homeowner worked hard to create a defensible space around the home. Notice that all fuel has been removed within the first 5 feet of the home, which survived the Waldo Canyon Fire in the summer of 2012. Photo: Christina Randall, Colorado Springs Fire Department*



**Figure 15:** *Clearing pine needles and other debris from the roof and gutters is an easy task that should be done at least once a year. Photo: CSFS*



**Figure 16:** *Enclosing decks with metal screens can prevent embers from igniting a house. Photo: Marilyn Brown, La Plata County*

The following actions help reduce continuous fuels surrounding a structure, while enhancing home safety and the aesthetics of the property. They also will provide a safer environment for firefighters to protect your home.

## Tree Thinning and Pruning

- Remove stressed, diseased, dead or dying trees and shrubs. This reduces the amount of vegetation available to burn, and makes the forest healthier.
- Remove enough trees and large shrubs to create at least 10 feet between crowns. Crown separation is measured from the outermost branch of one tree to the nearest branch on the next tree. On steep slopes, increase the distance between tree crowns even more.
- Remove all ladder fuels from under remaining trees. Prune tree branches off the trunk to a height of 10 feet from the ground or  $\frac{1}{3}$  the height of the tree, whichever is less.
- If your driveway extends more than 100 feet from your home, thin out trees within a 30 foot buffer along both sides of your driveway, all the way to the main access road. Again, thin all trees to create 10-foot spacing between tree crowns.
- Small groups of two or three trees may be left in some areas of Zone 2, but leave a minimum of 30 feet between the crowns of these clumps and surrounding trees.
- Because Zone 2 forms an aesthetic buffer and provides a transition between zones, it is necessary to blend the requirements for Zones 1 and 3. For example, if you have a tree in Zone 2 with branches extending into Zone 1, the tree can be retained if there is proper crown spacing.
- Limit the number of dead trees (snags) to one or two per acre. Be sure snags cannot fall onto the house, power lines, roads or driveways.
- As in Zone 1, the more trees and shrubs removed, the more likely your house will survive a wildfire.



**Figure 17:** In Zone 2, make sure there is at least a 10-foot spacing between tree crowns. Credit: CSFS

## Shrub Thinning/Pruning and Surface Fuels

- Isolated shrubs may be retained in Zone 2, provided they are not growing under trees.
- Keep shrubs at least 10 feet away from the edge of tree branches. This will prevent the shrubs from becoming ladder fuels.
- Minimum spacing recommendations between clumps of shrubs is  $2\frac{1}{2}$  times the mature height of the vegetation. The maximum diameter of the clumps themselves should be twice the mature height of the vegetation. As with tree-crown spacing, all measurements are made from the edge of vegetation crowns.
- Example – For shrubs 6 feet high, spacing between shrub clumps should be 15 feet or more (measured from the edge of the crowns of vegetation clumps). The diameter of these shrub clumps should not exceed 12 feet.
- Periodically prune and maintain shrubs to prevent excessive growth, and remove dead stems from shrubs annually. Common ground junipers should be removed whenever possible because they are highly flammable and tend to hold a layer of duff beneath them.
- Mow or trim wild grasses to a maximum height of 6 inches. This is especially critical in the fall, when grasses dry out.
- Avoid accumulations of surface fuels, such as logs, branches, slash and wood chips greater than 4 inches deep.



**Figure 18:** Pruning trees will help prevent a wildfire from climbing from the ground to the tree crowns. Credit: CSFS

## Firewood

- Stack firewood uphill from or on the same elevation as any structures, and at least 30 feet away.
- Clear all flammable vegetation within 10 feet of woodpiles.
- Do not stack wood against your home or on/under your deck, even in the winter. Many homes have burned as a result of a woodpile that ignited first.

## Propane Tanks and Natural Gas Meters

- Locate propane tanks and natural gas meters at least 30 feet from any structures, preferably on the same elevation as the house.
- The tank should not be located below your house because if it ignites, the fire would tend to burn uphill. Conversely, if the tank or meter is located above your house and it develops a leak, gas will flow downhill into your home.
- Clear all flammable vegetation within 10 feet of all tanks and meters.
- Do not visibly screen propane tanks or natural gas meters with shrubs, vegetation or flammable fencing. Instead, install 5 feet of nonflammable ground cover around the tank or meter.



**Figure 19:** Keep firewood, propane tanks and natural gas meters at least 30 feet away from structures. Photo: CSFS



**Figure 20:** This ponderosa pine forest has been thinned, which will not only help reduce the wildfire hazard, but also increase tree health and vigor. Photo: CSFS

## Zone 3

Zone 3 has no specified width. It should provide a gradual transition from Zone 2 to areas farther from the home that have other forest management objectives. Your local Colorado State Forest Service forester can help you with this zone.

This zone provides an opportunity for you to improve the health of the forest through proper management. With an assortment of stewardship options, you can proactively manage your forest to reduce wildfire intensity, protect water quality, improve wildlife habitat, boost the health and growth rate of your trees, and increase tree survivability during a wildfire.

In addition, properly managed forests can provide income, help protect trees against insects and diseases, and even increase the value of your property. Typical forest management objectives for areas surrounding home sites or subdivisions provide optimum recreational opportunities; enhance aesthetics; improve tree health and vigor; provide barriers against wind, noise, dust and visual intrusions; support production of firewood, fence posts and other forest commodities; or cultivate Christmas trees or trees for transplanting.

Consider the following when deciding forest management objectives in Zone 3:

- The healthiest forest is one that includes trees of multiple ages, sizes and species, and where adequate growing room is maintained over time.
- Remember to consider the hazards associated with ladder fuels. A forest with a higher canopy reduces the chance of a surface fire climbing into the tops of the trees, and might be a priority if this zone has steep slopes.
- A greater number of snags – two or three per acre, standing or fallen – can be retained in Zone 3 to provide wildlife habitat. These trees should have a minimum diameter of 8 inches. Make sure that snags pose no threat to power lines or firefighter access roads.
- While tree pruning generally is not necessary in Zone 3, it may be a good idea from the standpoint of personal safety to prune trees along trails and firefighter access roads. Or, if you prefer the aesthetics of a well-manicured forest, you might prune the entire area. In any case, pruning helps reduce ladder fuels within tree stands, thus reducing the risk of crown fire.
- Mowing grasses is not necessary in Zone 3.
- Any approved method of slash treatment is acceptable, including piling and burning, chipping or lop-and-scatter.



## Other Recommendations

### Windthrow

In Colorado, some tree species, including lodgepole pine, Engelmann spruce and Douglas-fir, are especially susceptible to damage and uprooting by high winds or windthrow. If you see evidence of this problem in or near your home, consider making adjustments to the defensible space guidelines. It is highly recommended that you contact a professional forester to help design your defensible space, especially if you have windthrow concerns.

### Water Supply

If possible, make sure that an on-site water source is readily available for firefighters to use, or that other water sources are close by. Lakes, ponds, swimming pools and hot tubs are all possible options. If there are no nearby water sources, consider installing a well-marked dry hydrant or cistern. If your primary water source operates on electricity, be sure to plan for a secondary water source. During wildfires, structures often are cut off from electricity. For more information on how to improve the accessibility of your water source, contact your local fire department.

## Recommendations for Specific Forest Types

The above recommendations refer primarily to ponderosa pine, Douglas-fir and mixed-conifer ecosystems. For other forest types, please refer to the additional recommendations below:

### Aspen

Tree spacing and ladder fuel guidelines do not apply to mature stands of aspen trees. Generally, no thinning is recommended in aspen forests, regardless of tree size, because the thin bark is easily damaged, making the tree easily susceptible to fungal infections. However, in older stands, numerous dead trees may be on the ground and require removal. Conifer trees often start growing in older aspen stands. A buildup of these trees eventually will increase the fire hazard of the stand, so you should remove the young conifers. Brush also can increase the fire hazard and should be thinned to reduce flammability.

### Lodgepole Pine

Lodgepole pine management in the WUI is much different than that for lodgepole pine forests located away from homes, communities and other developments. Normally, it is best to develop fuels management and wildfire mitigation strategies that are informed and guided by the ecology of the tree species. This is not the case with lodgepole pine.

Older lodgepole pine stands generally do not respond well to selective thinning, but instead respond better to the removal of all trees over a defined area to allow healthy forest regeneration. Selectively thinning lodgepole can open the stand to severe windthrow and stem breakage. However, if your home is located within a lodgepole pine forest, you may prefer selective thinning to the removal of all standing trees.

To ensure a positive response to thinning throughout the life of a lodgepole pine stand, trees must be thinned early in their lives – no later than 20 to 30 years after germination. Thinning lodgepole pine forests to achieve low densities can best be



*Figure 21: During high winds, these lodgepole pine trees fell onto the house. Lodgepole pine is highly susceptible to windthrow. Photo: CSFS*



*Figure 22: Mature aspen stands can contain many young conifers, dead trees and other organic debris. This can become a fire hazard. Photo: CSFS*



*Figure 23: A young lodgepole pine stand. Thinning lodgepole pines early on in their lives will help reduce the wildfire hazard in the future. Photo: CSFS*

**The defensible space guidelines in this quick guide are predominantly for ponderosa pine and mixed-conifer forests. These guidelines will vary with other forest types.**

accomplished by beginning when trees are small saplings, and maintaining those densities through time as the trees mature.

Thinning older stands of lodgepole pine to the extent recommended for defensible space may take several thinning operations spaced over a decade or more. When thinning mature stands of lodgepole pine, do not remove more than 30 percent of the trees in each thinning operation. Extensive thinning of dense, pole-sized and larger lodgepole pine often results in windthrow of the remaining trees. Focus on removing trees that are obviously lower in height or suppressed in the forest canopy. Leaving the tallest trees will make the remaining trees less susceptible to windthrow.

Another option is leaving clumps of 30-50 trees. Clumps are less susceptible to windthrow than solitary trees. Allow a minimum of 30-50 feet between tree crowns on the clump perimeter and any adjacent trees or clumps of trees. Wildfire tends to travel in the crowns of lodgepole pine. By separating clumps of trees with large spaces between crowns, the fire is less likely to sustain a crown fire.

### **Piñon-Juniper**

Many piñon-juniper (PJ) forests are composed of continuous fuel that is highly flammable. Fire in PJ forests tend to burn intensely in the crowns of trees. Try to create a mosaic pattern when you thin these trees, with a mixture of individual trees and clumps of three to five trees. The size of each clump will depend on the size, health and location of the trees. The minimum spacing between individual trees should be 10 feet between tree crowns, with increasing space for larger trees, clumps, and stands on steeper slopes.

Tree pruning for defensible space is not as critical in PJ forests as in pine or fir forests. Instead, it is more important to space the trees so that it is difficult for the fire to move from one tree clump to the next. Trees should only be pruned to remove dead branches or branches that are touching the ground. However, if desired, live branches can be pruned to a height of 3 feet above the ground. Removing shrubs that are growing beneath PJ canopies is recommended to reduce the overall fuel load that is available to a fire.

It is NOT recommended to prune live branches or remove PJ trees between April and October, when the piñon ips beetle is active in western Colorado. Any thinning activity that creates the flow of sap in the summer months can attract these beetles to healthy trees on your property. However, it is acceptable to remove dead trees and dead branches during the summer months.

For more information, please refer to the CSFS [Piñon-Juniper Management Quick Guide](http://www.csfs.colostate.edu) at [www.csfs.colostate.edu](http://www.csfs.colostate.edu).

### **Gambel Oak**

Maintaining Gambel oak forests that remain resistant to the spread of wildfire can be a challenge because of their vigorous growing habits. Gambel oak trees grow in clumps or groves, and the stems in each clump originate from the same root system. Most reproduction occurs through vegetative sprouts from this deep, extensive root system. You may need to treat Gambel oak near your home every five to seven years. Sprouts also should be mowed at least once every year in Zones 1 and 2. Herbicides can be used to supplement mowing efforts for controlling regrowth.

For more information, please refer to the CSFS [Gambel Oak Management](http://www.csfs.colostate.edu) publication at [www.csfs.colostate.edu](http://www.csfs.colostate.edu).

*Note: This publication does not address high-elevation spruce-fir forests. For information on this forest type, please contact your local CSFS district office.*



**Figure 24: Piñon-juniper forests are often composed of continuous fuels. Creating clumps of trees with large spaces in between clumps will break up the continuity. Photo: CSFS**



**Figure 25: Gambel oak needs to be treated in a defensible space at least every 5-7 years because of its vigorous growing habits. Photo: CSFS**

## Maintaining Your Defensible Space

Your home is located in a dynamic environment that is always changing. Trees, grasses and shrubs continue to grow, die or are damaged, and drop their leaves and needles each season. Just like your home, the defensible space around it requires regular, ongoing maintenance to be effective. Use the following checklists to build and maintain your defensible space.

### Defensible Space: Initial Projects

- Properly thin and prune trees and shrubs within Zones 1 and 2.
- Dispose of slash from tree/shrub thinning.
- Screen attic, roof, eaves and foundation vents, and periodically check them to ensure that they are in good condition.
- Screen or wall-in stilt foundations and decks; screens should be 1/8-inch or smaller metal mesh (1/16-inch mesh is best).
- Post signs at the end of the driveway with your last name and house number that are noncombustible, reflective and easily visible to emergency responders.
- Make sure that the driveway is wide enough for fire trucks to enter and exit, and that trees and branches are adequately cleared for access by fire and emergency equipment. Contact your local fire department or check the CSFS website for information specific to access.
- Take pictures of your completed defensible space for comparison of forest growth over time.



**Figure 26:** Keeping the forest properly thinned and pruned in a defensible space will reduce the chances of a home burning during a wildfire. Photo: CSFS

### Defensible Space Tasks: Annual Requirements

- Clear roof, deck and gutters of pine needles and other debris. \*
- Mow grass and weeds to a height of 6 inches or less. \*
- Rake all pine needles and other flammable debris away from the foundation of your home and deck. \*
- Remove trash and debris accumulations from the defensible space.\*
- Check fire extinguishers to ensure that they have not expired and are in good working condition.
- Check chimney screens to make sure they are in place and in good condition.
- Remove branches that overhang the roof and chimney.
- Check regrowth of trees and shrubs by reviewing photos of your original defensible space; properly thin and prune trees and shrubs within Zones 1 and 2.
- Dispose of slash from tree/shrub thinning. \*

\*Address more than once per year, as needed.



**Figure 27:** Sharing information and working with your neighbors and community will give your home and surrounding areas a better chance of surviving a wildfire. Photo: CSFS

### Be Prepared

- Complete a checklist of fire safety needs inside your home (these should be available at your local fire department). Examples include having an evacuation plan and maintaining smoke detectors and fire extinguishers.
- Develop your fire evacuation plan and practice family fire drills. Ensure that all family members are aware of and understand escape routes, meeting points and other emergency details.
- Contact your county sheriff's office and ensure that your home telephone number and any other important phone numbers appear in the county's Reverse 911 or other emergency notification database.
- Prepare a "grab and go" disaster supply kit that will last at least three days, containing your family's and pets' necessary items, such as cash, water, clothing, food, first aid and prescription medicines.
- Ensure that an outdoor water supply is available. If it is safe to do so, make a hose and nozzle available for responding firefighters. The hose should be long enough to reach all parts of the house.

Preparing your home and property from wildfire is a necessity if you live in the wildland-urban interface. It is important to adequately modify the fuels in your home ignition zone. Remember, every task you complete around your home and property will make your home more defensible during a wildfire.

Always remember that creating and maintaining an effective defensible space in the home ignition zone is not a one-time endeavor – it requires an ongoing, long-term commitment.

If you have questions, please contact your local CSFS district office. Contact information can be found at [www.csfs.colostate.edu](http://www.csfs.colostate.edu).

## List of Additional Resources

- The Colorado State Forest Service, <http://www.csfs.colostate.edu>
- CSFS wildfire-related publications, <http://csfs.colostate.edu/pages/wf-publications.html>
- Community Wildfire Protection Planning, <http://csfs.colostate.edu/pages/community-wf-protection-planning.html>
- Colorado's "Are You FireWise?" information, <http://csfs.colostate.edu/pages/wf-protection.html>
- National Fire Protection Association's Firewise Communities USA, <http://www.firewise.org>
- Fire Adapted Communities, <http://fireadapted.org/>
- Ready, Set, Go!, <http://wildlandfirersg.org/>



**Figure 28:** *This house has a high risk of burning during an approaching wildfire. Modifying the fuels around a home is critical to reduce the risk of losing structures during a wildfire. Photo: CSFS*



**Figure 29:** *This house survived the Fourmile Canyon Fire in 2010. Photo: CSFS*



**Figure 30:** *Firefighters were able to save this house during the 2012 Weber Fire because the homeowners had a good defensible space. Photo: Dan Bender, La Plata County*

**Colorado  
State  
FOREST  
SERVICE**

[www.csfs.colostate.edu](http://www.csfs.colostate.edu)

*This quick guide was produced by the Colorado State Forest Service (CSFS). CSFS programs are available to all without discrimination. No endorsement of products or services is intended, nor is criticism implied of products not mentioned.*

*FireWise Construction*



# **FireWise Construction:** *Site Design & Building Materials*

*Based on the 2009 International Wildland-Urban Interface Code*



## About the Authors

**David Bueche**, Ph.D., of Lakewood, Colo., works for Hoover Treated Wood Products, a major producer of fire-retardant-treated wood. He has more than 30 years of construction experience in both academia and industry. In addition to his hands-on experience as a carpenter, superintendent and project manager, he has been a research scientist at Colorado State University, taught college courses in construction and forest products, was a field representative for APA – The Engineered Wood Association and an applications engineer for the American Galvanizers Association. He is active in building code development, serves on the National Fire Protection Association (NFPA) and American Society for Testing and Materials (ASTM) committees that develop standards on the performance of materials in fire and building construction, is a member of the Society of Fire Protection Engineers, the Society of Wood Science and Technology and the Forest Products Society.

David developed sections 4 and 5 of this publication based on the 2009 International Wildland-Urban Interface Code.

**Tim Foley** most recently worked for the Colorado State Forest Service as the Northwest Colorado Fire Management Officer. Tim started his wildfire career with the Pike Hot Shots in 1977. He then worked for the Bureau of Land Management as a West Zone Fire Management Officer for the Upper Colorado River Interagency Fire Management Unit. Tim also serves on a wildfire Type 1 Team as a fire behavior analyst and fire investigator.

Tim was the main author of the first three sections of this publication.

## Dedication

**Peter Slack** of Boulder, Colo., was a practicing architect for 26 years, until his untimely death in June 2000. Peter designed many homes and other buildings in the wildland-urban interface (WUI). His designs emphasized the integration of fire-resistive elements with other important design principles, such as proper site development for limited impact, low energy and water consumption, and the use of appropriate, resource-conserving materials.

Peter developed the first iteration of this publication in 1999.

## Acknowledgements

Our thanks to the following for reviewing publication drafts:

Steve Quarles, Insurance Institute for Business and Home Safety

Chris Jennings, APA - The Engineered Wood Association

## Special thanks to:

Judy Serby, Conservation Education Program Manager, and Katherine Timm, Outreach Division Supervisor, Colorado State Forest Service, for providing leadership in the production of this report.

*December 2012*

## Introduction

Two factors have emerged as the primary determinants of a home's ability to survive a wildfire – quality of the defensible space and structural ignitability. Together, these two factors create a concept called the Home Ignition Zone (HIZ), which includes the structure and the space immediately surrounding the structure. To protect a home from wildfire, the primary goal is to reduce or eliminate fuels and ignition sources within the HIZ.

This publication addresses both defensible space and structural ignitability.

Sections 1 – 3 are based on a recent publication developed by the Colorado State Forest Service, *Protecting Your Home from Wildfire: Creating Wildfire-Defensible Space*.

Sections 4 and 5 are based on the 2009 *International Wildland-Urban Interface Code*.

In 2003, a growing awareness of wildfire risk led the International Code Council (ICC) to publish the first edition of the International Wildland-Urban Interface Code (IWUIC). This was the culmination of an effort initiated in 2001 by the ICC and the three statutory members of the International Code Council: Building Officials and Code Administrators International, Inc. (BOCA), International Conference of Building Officials (ICBO) and Southern Building Code Congress International (SBCCI). The intent was to draft a comprehensive set of regulations for mitigating hazards to life and property from the intrusion of fire resulting from wildland exposures and adjacent structures, and preventing structure fires from spreading to wildland fuels. Technical content of the 2000 Wildland-Urban Interface Code, published by the International Fire Code Institute, was used as the basis for development of the initial draft, followed by the publication of the 2001 final draft.

This updated publication is based on the 2009 IWUIC. It provides criteria for establishing an area's fire hazard severity as moderate, high or extreme, and spells out prescriptive measures for building within those zones. Local jurisdictions often use the IWUIC or adopt something similar for their communities. It is hoped that the information presented will help homeowners, designers and builders understand the unique issues associated with structure construction in the wildland-urban interface and encourage consistency in the application of provisions.





# Table of Contents

## 1. Wildfire in Colorado. . . . . 1

- What is the Wildland-Urban Interface?
- Fire suppression and increased fuels
- How can we protect our homes?
- Fire intensity and duration related to the fire resistance of a structure
- Evaluating fire hazard

## 2. Fire Behavior: Fuels, Topography and Weather. . . . . 4

- Wildfires and burning structures
- Vegetation is the fuel for wildfires
- Fire duration and fuel
- Fire behavior and slope
- Fire behavior, ignition of fuels: mechanisms of heat transfer
- Convective lifting
- Indirect: convective heating
- Radiant heating
- Direct contact or impingement
- Weather

## 3. Building-site Location and Landscaping . . . . . 9

- Topography and vegetation: fire behavior and intensity
- Aspect
- Dangerous topographic features: areas of more intense fire behavior
- Natural barriers and buffer zones
- Effects on structure location and design decisions
- Site design and modifications to the forest: developing a defensible space

## 4. Building Design . . . . . 13

- Simple vs. complex forms
- Aspect ratio
- Vents, eaves, soffits, gutters, downspouts and decks
- Ignition-resistant construction class

## 5. Building Materials and Components . . . . . 21

- Ratings
- Roofing
- Siding
- Windows and glass
- Doors

## 6. Summary . . . . . 31

## References and Additional Resources . . . . . 32



# 1. Wildfire in Colorado

This publication was developed to provide homeowners, building designers/builders and landscape architects with design, building and landscaping techniques for additional protection from wildfires in the wildland-urban interface (WUI).

It is not always possible to control a wildfire. Under extreme conditions, wildfires can threaten homes and other structures, infrastructure and evacuation routes. Planning and preparation can make the difference in personal safety and home protection.

## What is the wildland-urban interface?

The wildland-urban interface (WUI) is any area where structures and other human development meets or intermingles with wildland vegetative fuels.

Population growth in the WUI has increased, especially in the Western U.S. The expansion of subdivisions and other high-density developments has created conditions under which local fire departments cannot possibly protect all structures during a wildfire.



## Fire suppression and increased fuels

Past fire suppression and limited forest management have produced dangerous accumulations of fuels, causing hotter and more intense fires when they burn. The arrangement of these fuels causes fire to travel to the top of the forest, rather than staying close to the ground. These crown fires are extremely threatening to soils, habitat, property and people.

In some of Colorado's forests, naturally occurring low-intensity wildfires periodically burned through stands of trees, removing fuels and thinning out excess vegetation.

As population in the WUI has increased, so too has the difficulty of protecting that population. When fires occur in the WUI, they are suppressed to prevent the destruction of homes and other values at risk. This creates a problem because historically, some forests have depended on fire to maintain good health. Fire can thin trees and brush, and eliminate dead material. By fighting wildfires to protect homes and people, this natural process has been altered and vegetation density has increased, which provides more fuel for fires. When fires occur, the dense vegetation can burn more intensely, making it more destructive and dangerous.

## How can we protect our homes?

Construction in virtually every jurisdiction in the United States is regulated by building codes for the purpose of providing minimum public health and safety standards. Non-governmental model building code organizations, such as the International Code Council (ICC) and the National Fire Protection Association (NFPA), develop and maintain model building codes for use by state and local jurisdictions. A model building code is not enforceable until it is adopted by a state or local jurisdiction, with or without amendments, and becomes law. Several states, including Colorado, are "home-rule states." Under home rule, local governments have the ability to establish their own sets of codes and standards specific to their community. Because Colorado is a home-rule state and no statewide building code has been enacted as law, local jurisdictions adopt and/or adapt their own codes.

Typically, model codes allow the use of given building materials, while creating the parameters under which the material can be used. The concepts presented in this publication are based on the 2009 International Wildland-Urban Interface Code (IWUIC), the most widely adopted code addressing the WUI in the United States.

This comprehensive WUI code establishes minimum regulations for land use and the built environment in designated WUI areas, using prescriptive and performance-related provisions. It is founded on data collected through tests and fire incidents, technical reports and mitigation strategies from around the world. The IWUIC references the International Building Code (IBC), rather than the International Residential Code (IRC), the code most often adhered to by builders for home construction. This is because the IRC does not address several of the fire-resistive construction concepts that are necessary to meet the Ignition-Resistance Construction Classification. (*Ignition-resistant building materials are those that sufficiently resist ignition or sustained flaming combustion to reduce losses from WUI conflagrations under worst-case weather and fuel conditions with wildfire exposure to burning embers and small flames.*)

### **This publication offers a two-part approach to the problem:**

1. Build more ignition-resistant structures, and
2. Reduce hazardous forest fuels.

A combination of site/landscape management techniques and appropriate construction materials are necessary to build more ignition-resistant structures in the WUI. The goal is to create structures that can either resist fire on their own, or at least make it easier for firefighters to safely protect structures. Building a noncombustible structure, as often is done in urban settings, can be prohibitively expensive; this publication discusses a combination of cost-effective strategies that increase the probability a structure will survive a wildfire.

Solutions to problems in the WUI involve a two-part approach: Make structures more ignition-resistant and reduce surrounding wildland fuels. Choosing the best combination of these two strategies for a particular site requires a basic understanding of wildfire behavior.

- If we leave the surrounding wildland in its current state, we need to build structures that are resistant to fire. Noncombustible structures are very expensive to build.
- Trying to provide a defensible space large enough for a typical wood-frame structure may not be practical or desirable.

Another goal of this publication is to give homeowners, designers and builders a better understanding of how buildings in the WUI ignite during a wildfire. With this information, it is possible to make better choices when selecting building techniques and materials. However, fire is only one of many factors to consider during construction. There is no single approach, and using alternative materials or landscape management techniques is always possible.

Awareness of the unique issues landowners face when building in the WUI will help direct them toward a more comprehensive solution during the design process. Some design elements and materials may help mitigate fire hazards; some may not. It is possible, however, to compensate for less desirable fire protection choices and still meet design goals.

## Fire intensity and duration related to the fire resistance of structures

How ignition-resistant should a structure be? The answer to this question depends on fire intensity (how hot the fire burns) and fire duration (how long the fire will last at your site). If the fire hazard is low to moderate, only a few precautions may be necessary. If the fire hazard is high or extreme, most, or all, of the strategies described may be necessary.

In Colorado, almost any area surrounded by natural vegetation faces some hazard due to wildfire. In mountainous regions between elevations of 5,000 and 10,000 feet, fire hazard increases due to topography and increased vegetation density.

## Ember propagation potential in relation to structures

Burning embers, have caused the loss of many homes in the WUI. Embers in wildfires are produced when conifer trees are consumed by the fire. In WUI fires, burning structures also can be sources of burning embers. Flammable horizontal surfaces, such as wooden decks or shake roofs, are especially at risk for ignition from burning embers.

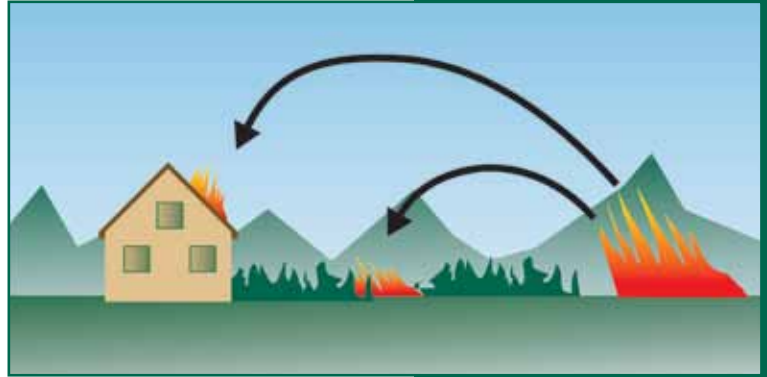

Figure 1-1: Fire brands, transported by convective lifting, create spot fires

## Evaluating fire hazards

An effective way to determine the specific fire hazard severity in an area is to look at a fire hazard map or study located in the county building or land use department. Your local fire protection district also may have information. The code officially establishes the fire hazard severity of your site based on section 502.1 (Appendix C) of the IWUIC. If this information is not immediately available, use Figure 1-2 to determine the hazard level of your site.

*This short evaluation is based on the Wildland Home Fire Risk Meter developed by the National Wildfire Coordinating Group.*

*Note: The term fire hazard severity in this publication refers to material elements used in building design and the actual design itself.*

Slope	Score
Level	0
0° - 10°	1
10° - 20°	2
20° - 30°	3
30°+	4
Vegetation	
water, rock or bare ground	0
grass, shrub, less than 2 feet with no trees	1
grass, shrub, less than 4 feet, widely scattered trees	2
dense young shrubs, no dead wood or trees	2
many trees, touching, some grass and brush	3
dense shrubs with some trees	3
thick, tall grass	3
dense evergreen trees with grass and shrubs	4
dense mature shrub with dead branches	4
After selecting the appropriate slope and vegetation scores, add them together to determine the fire hazard severity.	
Scores	Fire Hazard Severity
0 - 2	low
3 - 4	moderate
5 - 6	high
7 - 8	extreme

Figure 1-2: Fire hazard severity ratings

## 2. Fire Behavior: Fuels, Weather and Topography

### Wildfires and the nature of burning structures

#### Wildfires can ignite structures in two ways:

1. Direct flame contact with a moving fire. The fire behavior factors that influence a structure's potential for ignition are fire intensity and duration of flame contact.
2. An ignition started by a burning ember landing on a flammable surface, such as a shake roof or wooden deck.

Understanding the potential fire behavior, especially intensity, duration and ember deposition at a building site, will help homeowners, designers and builders determine how ignition-resistant a structure needs to be.

Wildfires have been studied in great detail to help predict fire behavior. Predicting fire intensity, rate of spread, duration, direction and spot-fire production is important for firefighter safety and is the basis for tactical decisions made during the suppression of a fire.

#### Three factors affect wildfire behavior in the WUI:

1. **Fuels:** The type, continuity and density of surrounding vegetation and, sometimes, flammable structures, provide fuel to keep the fire burning.
2. **Weather:** Wind, relative humidity and atmospheric stability all affect potential fire behavior.
3. **Topography:** The steepness and direction of slopes, and building-site location in relation to topography are features that affect fire behavior.

### Fuels are anything that burns in a fire

#### Wildland fuels are divided into four categories:

1. Grass
2. Brush or shrubs
3. Timber
4. Woody debris

All plants can burn under extreme conditions, such as drought; however, plants burn at different intensities and rates of consumption. The type and density of a specific plant determines how it will burn. Some vegetation rarely burns, while other vegetation burns at different times of the year; and some can burn almost anytime. The amount of moisture in the fuels is the biggest factor affecting flammability.

**Grasses:** Grass primarily exists in two conditions – green and cured. When grass is green, moisture content is high enough to prevent or decrease fire spread. Firefighters sometimes use green meadows and lawns as safety zones. As the year progresses, plants enter a dormant state and the residual surface vegetation dies. Cured grass has the potential to promote extreme fire rates of spread (ROS); grass fuels have the highest potential ROS of any fuels. Another hazard associated with cured grass is the potential for a rapid decrease in fuel moisture; the ability of air to circulate through standing grass allows the grass to dry rapidly and can result in sudden changes in fire behavior.

**Brush:** Brush fires spread slower than grass fires, but burn at a higher intensity. The most common flammable brush species in Colorado are oak brush and sagebrush. Brush is least flammable in late spring when new growth occurs.

**Timber:** Timber burns in two manners – as surface fires and crown fires. Surface fires consume fuels on the forest floor without burning trees, although trees may burn individually, which is called torching. Crown fires occur when entire stands of trees are totally consumed. These fires are the most intense, but tend to move less rapidly than other types of fire. Coniferous trees are more susceptible to crown fire than deciduous trees. Torching and crown fires are the major source of ember production, which can start new fires (spot-fires) in vegetation and structures downwind.

**Woody debris:** Dead logs, branches and sticks on the ground surface are referred to as woody debris. Debris can result from human activity, such as thinning, or from natural processes, such as wind-throw or beetle-killed trees that have fallen to the ground. Wildfires in these fuels vary greatly, but can produce high-intensity, slow-moving fires that are very difficult to control. Colorado's mountain pine beetle epidemic will result in a major increase in woody debris over large areas.

**Complexes:** More than one fuel component is present in most wildland areas. Areas containing these fuel complexes are more common than those represented by a single fuel component.

**Structures:** The effect of a burning structure can significantly impact wildfire behavior. Structures burn with extreme intensity, often launching large burning embers over long distances.

**Fuels and fire duration:** Fire duration refers to the length of time a wildfire will burn under certain conditions. Fuel type, quantity, temperature and moisture content determine the duration of a fire. Building structures that will resist fires for any length of time is dependent on a good understanding of local conditions that contribute to the duration of fire in a particular area. Different building materials can resist fire for different time periods.

## Climate and Weather

**Climate:** Fire seasons in Colorado's high country and on the Western Slope tend to last from late spring until mid-autumn. Fire seasons on the Front Range and Eastern Plains tend to be split, with most large fires occurring in the spring or fall. It's important to keep in mind that these are generalizations and that large fires can occur anytime conditions are right. The most likely fire season depends on the geographical location of the building site.

Weather is a major factor that affects fire behavior and is highly variable in terms of time, intensity and location. Weather can change dramatically in a short period of time, resulting in rapid changes in fire behavior.

**Wind:** Surface winds are the most important element in determining fire direction and rate of spread. Wind pushes flames into adjacent fuels, facilitating rapid ignition, and tends to be the common theme in large fire events. High-velocity, warm, dry, down-slope winds, such as a Chinook, can cause fuels to dry rapidly, resulting in extreme fire behavior.

**Relative Humidity (RH):** RH is a measure of how much moisture is in the air compared to the maximum amount of moisture the atmosphere can hold at that temperature. RH has a major influence on the moisture content of dead fuels. The smaller the dead fuel, the faster it will react to a change in the RH. Cured grass can dry out in less than 15 minutes when a dry air mass moves into an area. Firefighters generally monitor RH on an hourly basis when fighting a fire.

**Temperature:** Before combustion can occur, fuels must reach ignition temperature (approximately 450° F); fuels heat up and reach ignition temperature more quickly on hot days. In addition, when fuels are preheated, fire expends less energy and will burn at a higher intensity.



## Topography and Fire Behavior

Topography is the shape of the land's surface. It influences fire behavior by the effects it has on wind, temperature, moisture and the preheating of fuels.

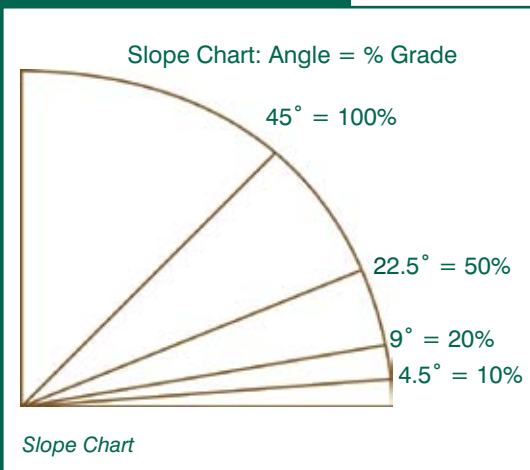

Figure 2-1: Slope chart

**Slope:** Defined as the angle of the ground relative to the horizon, slope commonly is measured in degrees or as a percent. On calm days, heated air, including flames, rises and preheats the fuels upslope, which causes an increase in fire spread. On gentle slopes, preheating has little effect on fire behavior, but on steep slopes, the effect can be significant. During summer months, preheating generally causes winds to blow upslope. The combined effect of slope and wind results in rapid fire spread.

**Aspect:** Aspect is the direction the slope faces. South and southwest aspects are warmer and drier than north and northeast aspects.

**Saddles and Chimneys:** A saddle is a low spot on a ridge. A chimney is a gully or drainage that goes up a slope. Both saddles and chimneys funnel winds and increase fire spread and intensity.

Structures located on steep slopes or in saddles or chimneys require more ignition-resistant components and/or larger defensible space.

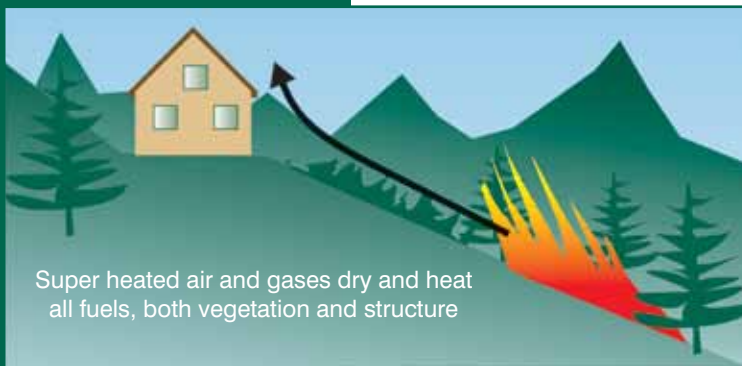

Figure 2-2: Super heated air and gases rise and heat fuels

### Fire behavior and ignition of fuels: heat transfer mechanisms

As fuels burn, they release hot gas in the form of flames and smoke. These gases rise and move with the wind. Sometimes embers are carried aloft by this convective lifting. These hot gasses also heat fuels in which they come in contact, bringing those fuels closer to their ignition point. Fires also produce large amounts of radiant energy (like the sun), which heats surrounding fuels. Ignition occurs more easily once flames make contact with the vegetation. This, in turn, accelerates the rate at which the fire moves and increases in intensity.

Several heat-transfer mechanisms from a wildfire are involved in the ignition of a structure:

- Radiant heating that results in an ignition or heats a flammable surface makes structures more susceptible to ignition from another source.
- Direct flame contact with a flammable portion of the structure can cause ignition.
- Convective lifting resulting in ember deposition on a flammable surface can cause ignition.

Understanding these processes will help design structures and landscapes that reduce wildfire risk.

## Indirect: radiant heating

The transfer of heat by radiant energy from fire can preheat or even ignite structures. This is the same process that occurs when sunlight heats an object. Radiant heat transfer occurs on a straight line of sight and is not affected by wind.

Vertical surfaces, such as siding, can ignite as a result of this process before fire actually reaches the structure. Curtains can ignite from radiant heat transferred through windows. Torching trees and crown fires nearby can cause high levels of radiant heat for short to moderate durations. Adjacent burning structures create intense radiant heat for long durations. And once ignited, large, heavy fuels burn at high temperatures that amplify radiant energy, creating more potential for ignition through heat transfer.

Radiant energy decreases with distance. It follows the inverse square rule shown in Figure 2-4. Doubling the distance from the heat source will reduce radiant heat by significantly more than half. A torching tree 10 feet from a structure will produce four times more radiant heat than the same tree torching 20 feet from a structure. Radiant heat energy decreases dramatically with increased distance.



Figure 2-3: Radiant heating

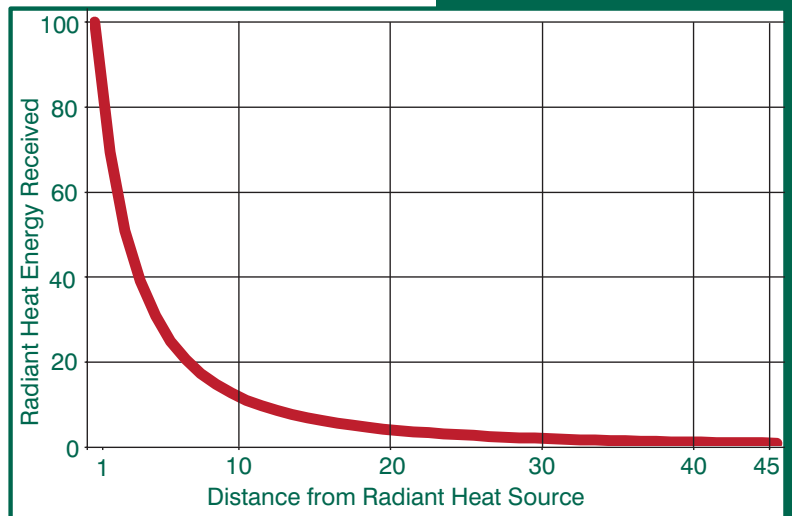

Figure 2-4: Radiant energy decreases with increased distance

## Direct contact or impingement

Unmanaged vegetation adjacent to a structure provides continuous and abundant fuels, which can ignite flammable building surfaces. Creating defensible space and fuelbreaks around a structure is specifically intended to reduce this effect.



Figure 2-5: Fire directly impinging on a house

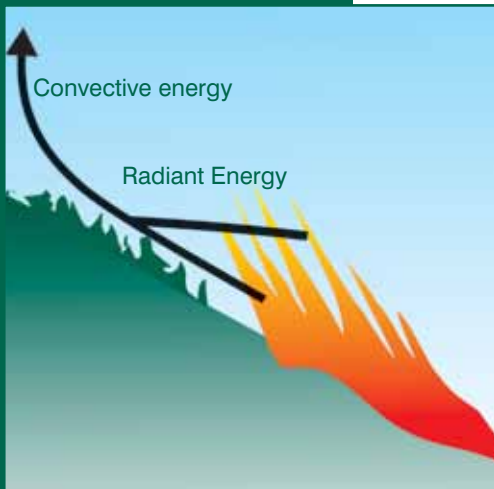

Figure 2-6: Convective and radiant energy from a fire

### Convective lifting

Fire produces hot gases that rise into the atmosphere. During a wildfire, this atmospheric effect can be very strong, even causing its own wind as cooler air rushes in to replace the rising hot air.

Convective air currents also lift burning materials or embers. Winds can carry embers horizontally for long distances from the fire.

Embers can fall onto horizontal surfaces, such as combustible roofs, decks and dry vegetation around structures. When this results in a new ignition, it is called spotting and can be very widespread. Embers often travel hundreds or even thousands of feet ahead of the actual fire.

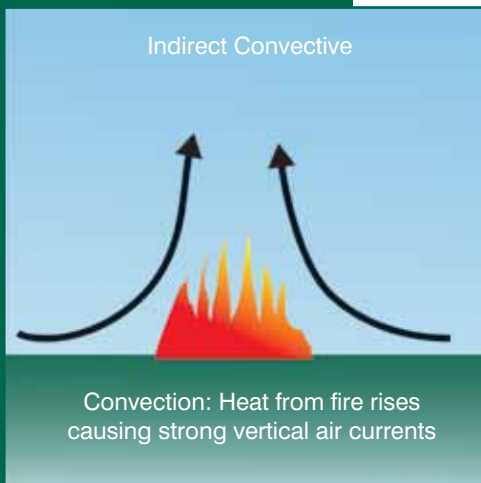

Figure 2-7: Convective lifting

### Indirect: convective heating

The same hot air and gasses that dry and preheat vegetation have the same effect on structures, predisposing combustible materials to ignition as the fire gets closer.

### 3. Building-site Location and Landscaping

#### Topography and vegetation: fire behavior and intensity

Structure location influences the potential fire intensity and duration to which that structure may be exposed. The information in the fire behavior section (Section 2) discussed how to estimate fire intensity and duration. This information can be used to determine the building site that will allow the highest probability of survival in the event of a wildfire. When choosing a site or determining the level of ignition resistance a structure requires, homeowners, designers and builders should be aware of how local vegetation and topographic variations affect fire behavior.

#### Aspect

Aspect is the direction that the slope faces. Vegetation varies widely between the extremes of south-facing and north-facing slopes.

South and west slopes tend to have the least vegetation because they quickly dry out and have less available moisture for plants. Southwest slopes tend to have the fastest moving fires.

East aspects generally have more vegetation than southwest slopes and tend to dry out in later in the summer.

North slopes typically have the densest vegetation because there is more water available for plants. Because the moisture content of the vegetation on north slopes is higher, fires tend to burn with less intensity. However, when fires occur during times of drought, they can burn with greater intensity because of the increased amount of fuels.

#### Dangerous topographic features: areas of more intense fire behavior

Variations in topographic features such as valleys, ridges, canyons and saddles present hazards that further intensify or attract fires. A **valley**, as a concave form, tends to collect and concentrate winds. This means that the intensity of a wildfire can increase as it moves through a valley. In **canyons**, this effect is even more pronounced. **Ridges** experience more wind primarily because they are elevated above the surrounding land. When a fire moves up a slope toward a ridge, it gathers speed and intensity. A low point between the higher parts of a ridge is called a saddle. Like a valley, saddles will channel, intensify and increase the fire's rate of spread. These areas often are popular building sites because they offer some shelter and tend to be flat. **Saddles** are natural pathways for fire; fire often travels first and with increased intensity in saddles. As wind crosses a ridge, a leeward eddy can occur, where the wind rolls around and comes up the leeward side, exposing both sides of a structure to wind and fire. Ridges usually offer no protection from fire.

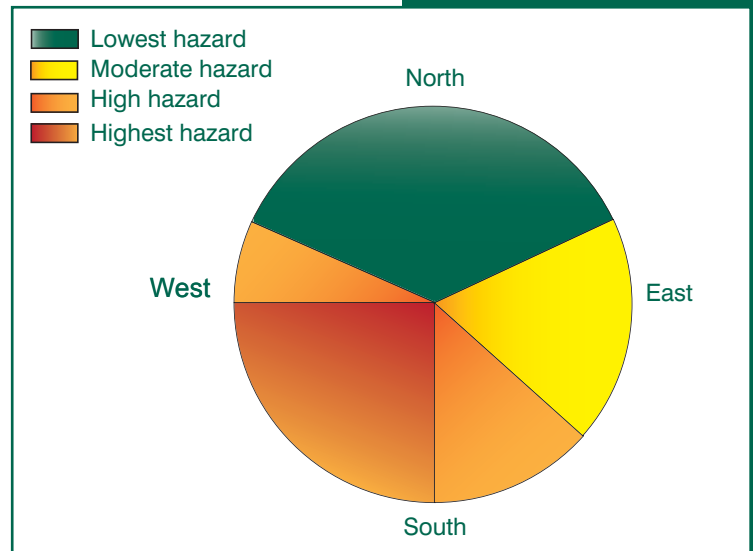

Figure 3-1: Fire hazard varies widely from aspect to aspect

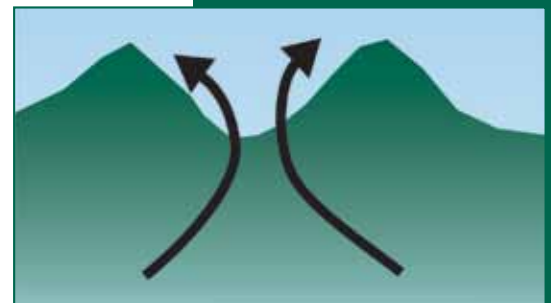

Figure 3-2: Saddle, or low area, on a ridge



Figure 3-3: Ridge with wind exposure

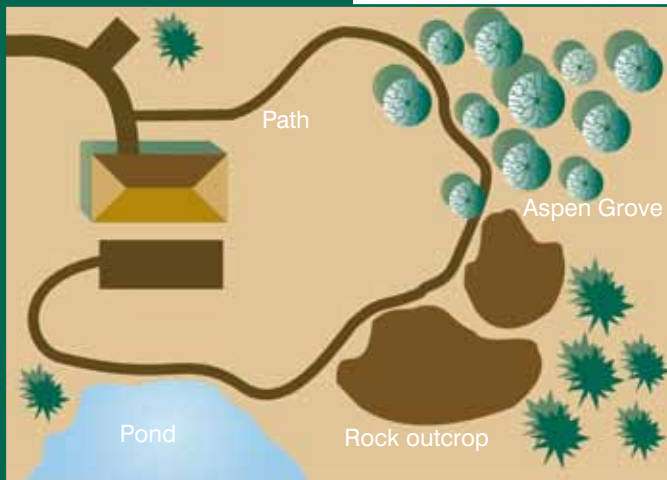

Figure 3-4 Site: House located relative to natural features that buffer against fire

## Natural barriers and buffer zones

Some physical features reduce fire behavior and can be used to slow, reduce or deflect a fire. Examples include natural rock outcroppings, wetlands, streams, lakes and deciduous tree stands, (aspen, cottonwood, etc). It is advantageous to locate the structure between the natural barrier and the anticipated path of a fire. Some areas, such as meadows or lawns, can be barriers at certain times of the year, but serve as fuels after they cure.

## How this affects building location and design decisions

On large parcels of land, consider the physical features previously discussed when choosing the final location of a structure. Many factors will affect decisions regarding building-site location, such as privacy, views, access and aesthetic values; fire is just one of these factors. Determining whether fire is the primary consideration will depend on the severity of the fire hazard in the area.

On smaller parcels, only one suitable building location may exist. The physical features of the site will determine the probable fire intensity and dictate what combination of site modifications and fire protection is necessary to prevent the structure from igniting.

## Site Evaluation, Design, and Modifications to the Vegetation

When selecting a building site, several questions should be answered:

1. Is there adequate ingress and egress in the event of a fire?
2. Can fire engines and other emergency equipment safely access the property?
3. Can close-in fuels be modified to reduce fire potential (defensible space)?
4. What is the potential fire behavior and ember production in the fuels further out?

After evaluating the fire hazard severity of a site, develop a plan to manage the surrounding vegetation and defensible space. This is the first part of the two-part strategy to build an ignition-resistant structure. Defensible space is defined as an area where material capable of allowing a fire to spread is modified to slow the rate and intensity of an advancing wildfire, and create an area for firefighters to safely work. It also can work in reverse by helping to prevent a structure fire from spreading to surrounding vegetation.

In diagramming the features of a building site, it is apparent that the features gradually shift from man-made to natural, as the distance increases from the structure into the wildland; this area should be divided into zones. Developing a defensible space plan requires an inventory of the existing site features and their hazards. Man-made elements include landscaping features, such as masonry walls, patios, footpaths and driveways. These features create fire barriers and buffer zones. Three zones need to be addressed when creating defensible space:

**Zone 1** is the area nearest the home and requires maximum hazard reduction.

**Zone 2** is a transitional area of fuels reduction between Zones 1 and 3.

**Zone 3** is the area farthest from the home, where traditional forest management techniques should be used. It extends from the edge of Zone 2 to the property boundaries.

**Zone 1** – The width of Zone 1 extends a distance of 15 - 30 feet minimum from a structure depending on property size. Increasing the distance of Zone 1 will increase structural survivability. This distance should be increased five or more feet for fuels downhill from a structure. Remove most flammable vegetation, with the possible exception of a few low-growing shrubs or FireWise plants (plants that are comparatively fire resistant). Avoid landscaping with common ground junipers. The distance should be measured from the outside edge of the home's eaves and any attached structures, such as decks. Several specific treatments are recommended within this zone:

- Install nonflammable ground cover and plant nothing within the first 5 feet of the structure and deck.
- If a structure has noncombustible siding (i.e. stucco, synthetic stucco, concrete, stone or brick), widely spaced foundation plantings of low-growing shrubs or other FireWise plant materials are acceptable. Do not plant directly under windows or next to foundation vents.
- Prune and maintain plants and remove all dead branches, stems and leaves within and below the plant.
- Irrigate grass and other vegetation during the growing season if possible. Keep grasses mowed to a height of 6 inches or less.
- Do not store firewood or other combustible materials in this zone. Keep firewood at least 30 feet away from structures, uphill if possible.
- Enclose or screen decks with at least 1/8-inch metal screening (1/16-inch is preferable). Do not use areas under decks for storage.
- Ideally, remove all trees from Zone 1 to reduce fire hazards. The more trees you remove, the safer the home will be. If you do retain any trees, consider them part of the structure and extend the distance of the entire defensible space accordingly.
- Remove any branches that overhang or touch the roof, and remove all fuels within 10 feet of the chimney.
- Remove all needles and other debris from the roof, deck and all gutters.
- Rake needles and other debris at least 10 feet away from all decks and structures.
- Remove slash, chips other woody debris from Zone 1.

**Zone 2** – Zone 2 is an area of fuels reduction designed to reduce the intensity of any fire approaching structures. The width of Zone 2 depends on the slope of the ground where the structure is built. Typically, the defensible space in Zone 2 should extend at least 100 feet from all structures. If this distance stretches beyond the property line, try to work with the adjoining property owners to complete an appropriate defensible space.

The following actions help reduce the continuous fuels surrounding a structure, while enhancing home safety and the aesthetics of the property. It also will provide a safer environment for firefighters to protect homes.

- Remove stressed, diseased, dead or dying trees and shrubs.
- Remove enough trees and large shrubs to create at least 10 feet between crowns. Crown separation is measured from the farthest branch of one tree to the nearest branch on the next tree. On steep slopes, increase the distance between tree crowns.

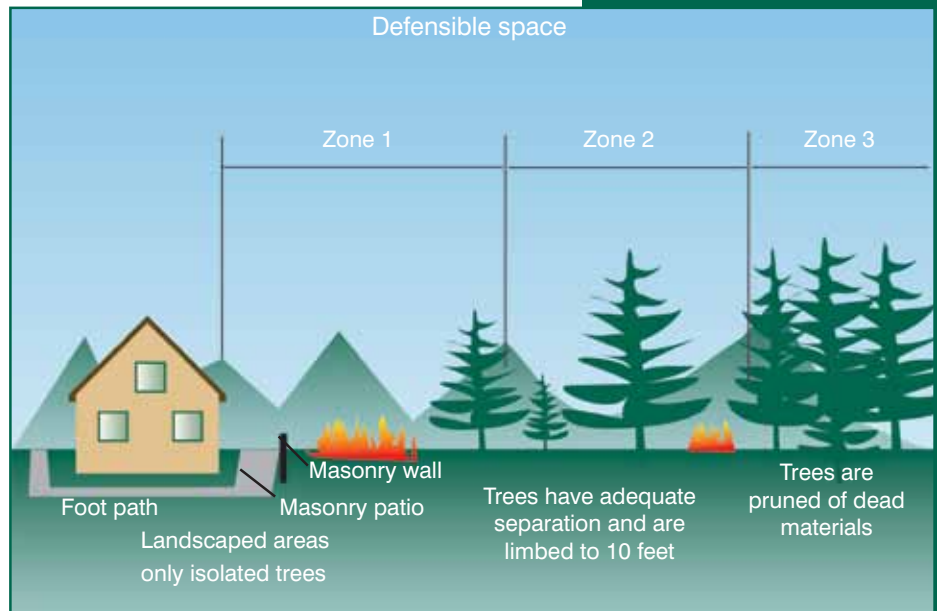

Figure 3-5: Defensible space

- Remove all ladder fuels from under remaining trees. Prune tree branches to a height of 10 feet from the ground or 1/3 the height of the tree crown, whichever is less.
- Extend tree thinning out 30-feet along both sides of your driveway all the way to the main access road, even if it is over 100 feet from your home. Thin all trees to create 10-foot spacing between tree crowns.
- Small groups of two to three trees may be left in some areas of Zone 2, but leave a minimum of 30 feet between the crowns of these clumps and surrounding trees.
- As noted in Zone 1, the more trees and shrubs removed, the more likely the structure will be spared in a wildfire.
- Isolated shrubs may remain, provided they are not under trees.
- Keep shrubs at least 10 feet away from the edge of tree branches. This will prevent the shrubs from becoming ladder fuels.
- Minimum spacing recommendations between clumps of shrubs is 2 1/2 times the mature height of the vegetation. The maximum diameter of the clumps themselves should be twice the mature height of the vegetation. As with tree-crown spacing, all measurements are made from the edge of vegetation crowns.
- Periodically prune and maintain shrubs to prevent excessive growth; remove dead stems from shrubs annually.
- Mow or trim grasses to a maximum height of 6 inches. This is critical in the fall when grasses dry out.
- Avoid accumulations greater than 4 inches deep of surface fuels such as logs, branches, slash and chips.
- Stack firewood and woodpiles uphill from or on the same elevation as any structures, and at least 30 feet away.
- Clear, mow and remove all flammable vegetation within 10 feet of woodpiles.
- Do not stack wood against your home or on/under your deck, even in winter.
- Locate propane tanks and natural gas meters at least 30 feet from any structures, preferably on the same elevation as the structure. The containers should not be located below your home because if it ignites, the fire would tend to burn uphill. Conversely, if the tank or meter is located above your structure and it develops a leak, gas will flow downhill into your home.
- Clear and remove flammable vegetation within 10 feet of all tanks and meters.
- Do not visibly screen propane tanks or natural gas meters with shrubs, vegetation or flammable fencing. Instead, install 5 feet of nonflammable ground cover around the tank or meter.

**Zone 3** – Zone 3 has no specified size. It should provide a gradual transition from Zone 2 to areas farther from the home that have other forest management objectives. Your local Colorado State Forest Service forester can help you with this zone.

Forest management in Zone 3 provides an opportunity to improve the health of the forest. With an assortment of tools and alternatives, it is possible to proactively manage forest land to reduce wildfire intensity and protect water quality, increase habitat diversity for wildlife, increase the health and growth rate of trees and increase the survivability of trees in a wildfire.

For additional information about defensible space, see [Protecting Your Home from Wildfire: Creating Wildfire-Defensible Space](#) or visit <http://csfs.colostate.edu/pages/wf-publications.html>.

## 4. Building Design

So far, we have discussed elementary fire behavior and how to manage the wildlands surrounding a home in the interface. The second part of our approach to building ignition-resistant structures is learning about appropriate design and material choices.

### Simple vs. complex forms

Simple building forms have less surface area relative to the volume of the structure. Complex building forms have much more surface area relative to volume. Simple building forms are less expensive to build, more energy efficient and easier to protect from wildfires. There is simply less exterior surface to protect.

Complex forms not only increase the surface area of the structure, but also create shapes that trap the fire's heat; these areas are called heat traps. Transitions between vertical surfaces and horizontal surfaces, inside corners between two walls or abrupt intersections of different solid planes form pockets where wind velocity drops and eddy currents form.

Parapet walls, solar collectors, intersecting roofs and walls, roof valleys and decks are examples of heat traps. These forms cannot be avoided, therefore their locations require much more attention to ignition-resistant materials. Burning embers most often fall in these locations when wind velocity decreases.

Roofs are very susceptible to embers in a wind-driven fire. A simple roof form such as a hip or straight gable is best. Complicated roofs with intersecting planes and valleys form dead air pockets and areas where currents eddy. The use of complicated forms further highlights the importance of a truly ignition-resistant roof.

Some roof coverings have gaps that allow ember intrusion under the covering and can result in ember intrusion and ignition of the structure under the roof covering. The worst types of roof coverings allow combustible debris to blow or rodents and birds to build nests under the roof covering. This can occur in clay (Spanish or straight-barrel mission) tile roof covering unless eave closures or "bird stops" are used to close the convex opening created by the shape of the tile at the eave. If you can see wood through gaps in the roof covering, embers can penetrate and ignite the structure.

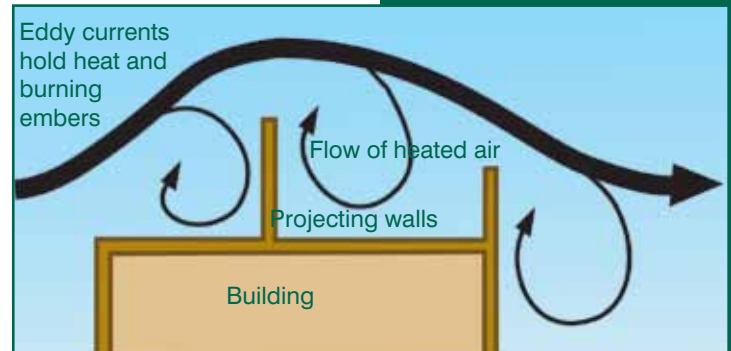

Figure 4-1: Heat traps around walls

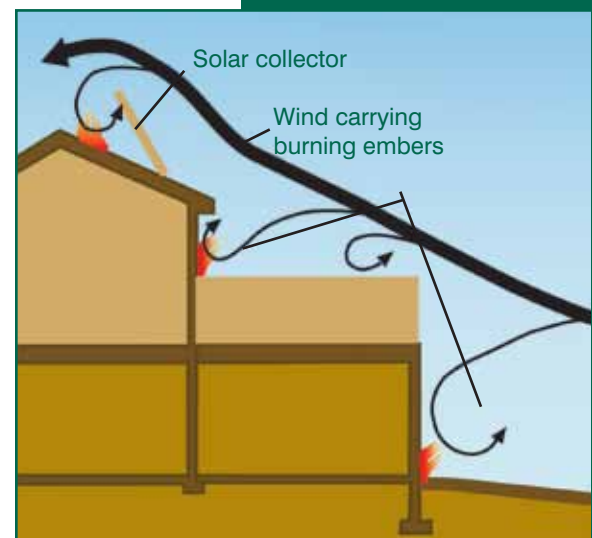

Figure 4-2: Heat traps around roofs

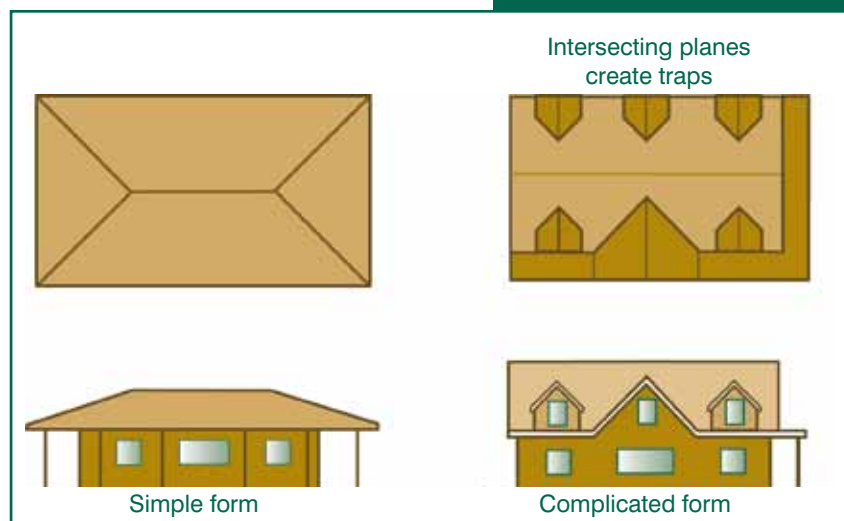

Figure 4-3: Roof forms



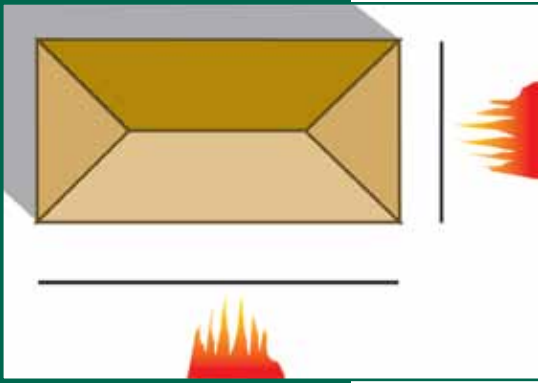

Figure 4-4: Aspect ratio is the ratio between the east-west axis and the north-south axis.

## Aspect ratio

Aspect ratio is the ratio between the east-west axis and the north-south axis. In Colorado's climate, it generally is better to build a structure that is longer on the east-west axis than the north-south axis. Such a structure has a more favorable energy relationship with the climate and can benefit from passive solar heat.

With regard to wildfire, if the widest exterior of the structure faces the direction from which a fire is likely to come, it will be more vulnerable. More fire-resistant materials and components are needed on the side that faces oncoming fire. On a flat site, the direction of a fire is somewhat unpredictable, but it generally is determined by predominant winds and fuel.

The probable fire path is more easily predicted on sloping sites. Fire can be expected to approach up the slope. On east- and west-facing slopes, it is best to locate the structure on the longer east-west axis in terms of energy efficiency and fire risk, as the widest side of the structure faces the winter sun and the narrowest side faces the fire path.

When simple forms and optimum aspect ratios cannot be used, the structure will require more ignition-resistant building materials.

## Vents, eaves, soffits, gutters, downspouts and decks

Building an ignition-resistant structure can be compared to building a watertight roof. One little hole in the roof allows water to leak in, and it doesn't matter how well the job was done on the rest of the roof, it failed and damage occurred. Small building elements like soffits and vents can be the weak link in a fire. An otherwise ignition-resistant structure can be damaged or destroyed because fire found a way in through these areas.

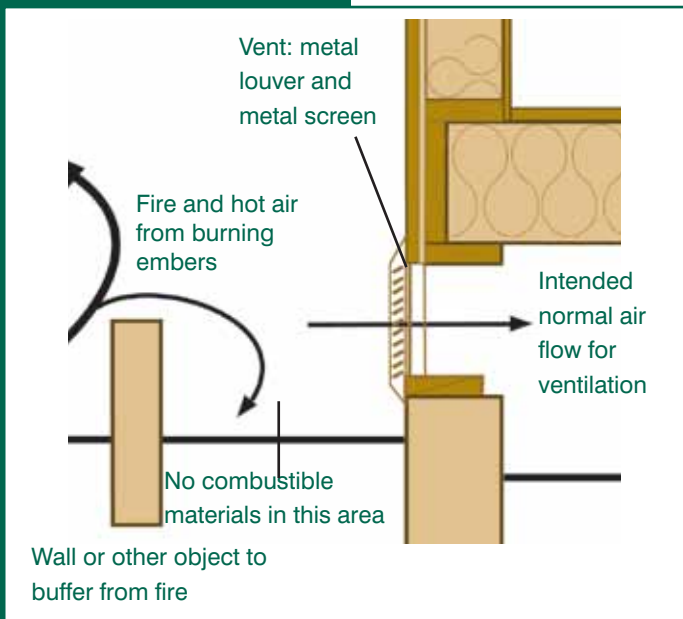

Figure 4-5: Crawl-space ventilation

## Vents

The International Building Code (IBC) requires vents to prevent accumulation of water vapor in the structure. All crawl spaces under wood floors are required to have ventilation. One square foot of vent is required for every 150 square feet of floor area. Because these vents typically are located near the ground, combustible vegetation should not be located next to them.

Vents located on the downhill side of the structure should be protected by landscaping elements, such as stone patios or walls, that block the direct path of the fire. Mechanical ventilation with intakes and exhaust located away from the ground also can be used.

All attic spaces and roof cavities are required to have ventilation. One square foot of vent is required for every 300 square feet of horizontal projected roof area (see eaves and soffits). In both cases, the vents should be covered with noncombustible, corrosion-resistant mesh with openings that do not exceed ¼-inch, or be designed and approved to prevent flame or ember penetration into the structure. Roof turbine vents also should be screened to prevent embers from entering attic spaces.

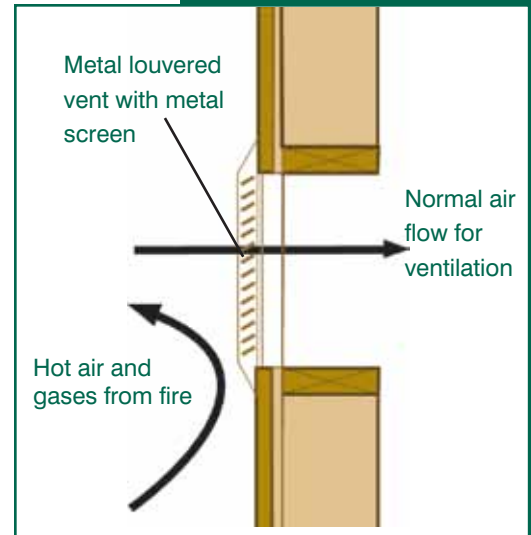

Figure 4-6: Attic vent

### Eaves and soffits

The extension of the roof beyond the exterior wall is the eave. This architectural feature is particularly prone to ignition. As fire approaches the structure, the exterior wall deflects the hot air and gasses up into the eave. If the exterior wall isn't ignition resistant, this effect is amplified.

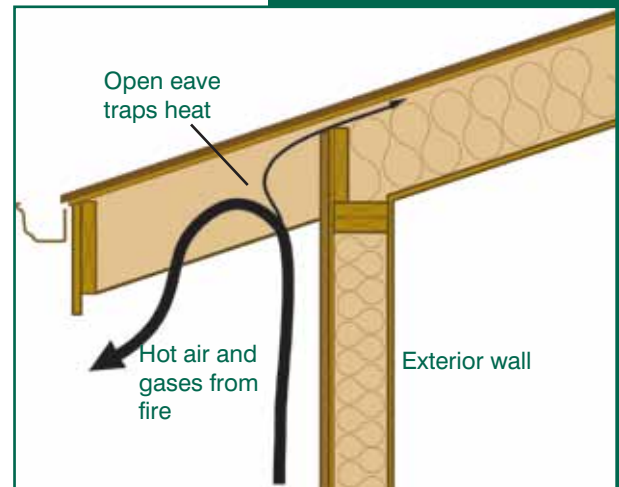

Figure 4-7: Open eave with no soffit

The eave should be covered with a soffit. If the soffit is applied directly to the rafter eave, it forms a sloping soffit, which creates a pocket that can trap fire.

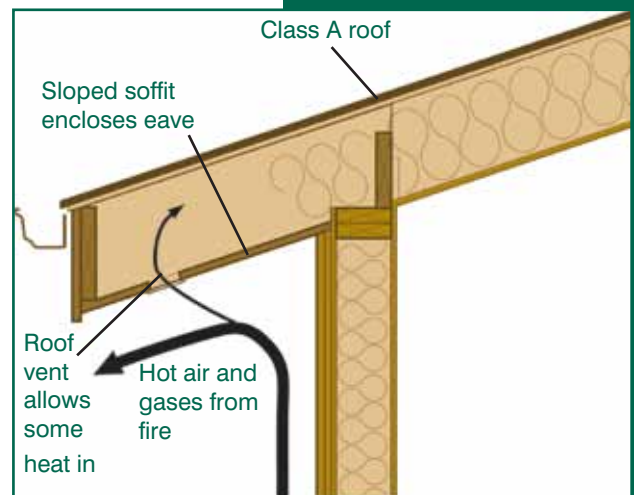

Figure 4-8: Open eave with soffit

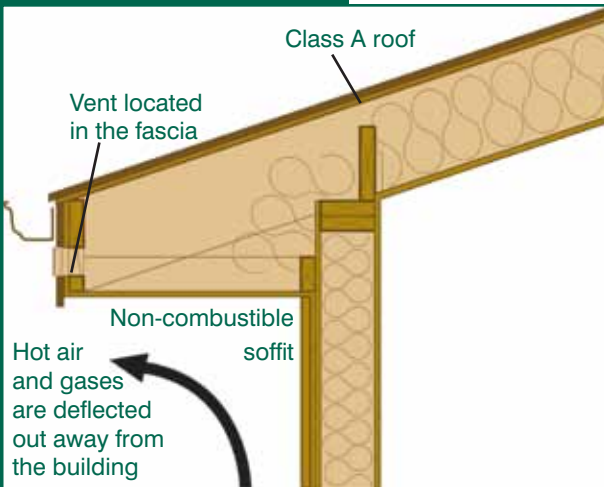

Figure 4-9: Fully enclosed soffit with isolated vent

A flat soffit allows the structure to more readily deflect fire outward. Vents for roof ventilation often are found in the soffit. Placing vents in these locations creates a path for fire to enter the roof structure. If the vent must be placed in this location, it is better to place it farther from the wall and closer to the fascia. The vent also can be placed in the fascia or near the lower edge of the roof.

### Gutters and downspouts

Gutters and downspouts collect leaves and pine needles. Gutters and eave troughs made from combustible materials (e.g., wood, vinyl) are as vulnerable to ember collection as the roof and other parts of the structure. If leaf litter is allowed to gather in gutters, embers can ignite the leaf litter, which in turn could ignite combustible eave materials or overhangs. If gutters are attached to combustible fascia boards, the fascia board should be considered a possible fuel that can be ignited by fine fuels burning in the gutters.



Figure 4-10: Conventional deck in a fire

### Decks

Decks are a popular and well-used feature of the structure, especially in the mountains. Because they are elevated above the terrain and surrounding vegetation, they offer a better view and provide flat areas for walking on otherwise sloping terrain.

Most decks are highly combustible structures. Their shape traps hot gasses, making them the ultimate heat traps. And because they often face downhill – they allow easy access to an approaching fire, which most likely is moving up a slope.

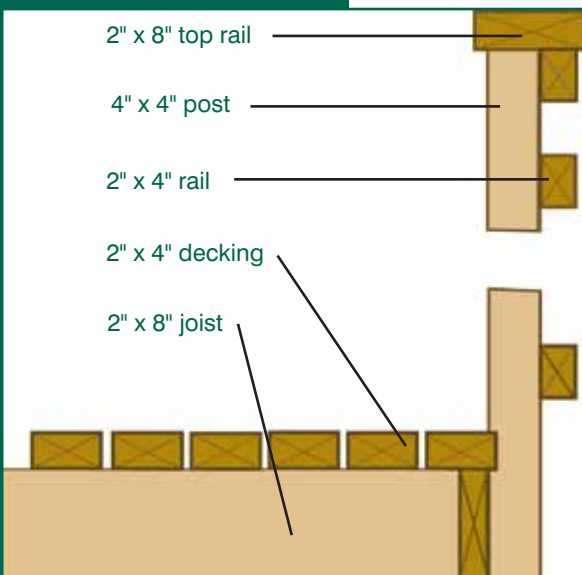

Figure 4-11: Conventional deck construction detail

Decks are built to burn almost as easily as wood stacked in a fireplace. All the components of a deck – joists, decking and railings – generally are made of wood, plastic or wood-plastic composites generally no more than 2 inches thick with high surface-to-volume ratios.

When fire approaches, deck material quickly heats up. Ignition can easily occur when the radiant energy from the fire gets hot enough or a burning ember lands on it.

## Ignition of decks

Conventional decks are so combustible that when a wildfire approaches, the deck often ignites before the fire gets to the structure.

Normally, decks ignite in one of two ways. A burning brand landing on the surface of the deck is all that's required, particularly if the decking is dry or has wide gaps between the boards, which allows airflow and harbors embers. Similarly, space between the first deck board and the structure can provide airflow and catch embers, increasing the risk that the siding will ignite.

The other common cause of deck fires is direct flame from unmaintained vegetation igniting the deck from below, or a burning brand igniting debris under the deck. Again, dry or widely spaced deck boards speeds the spread of fire.

Once the deck ignites, it may set the structure on fire. Heat from the deck fire, for example, may cause the glass in a sliding door to break, permitting flames to enter the interior of the structure. Or, combustible siding or soffits can ignite, carrying fire to the structure. The end result is the same. Even if the structure itself doesn't ignite, the structural integrity of the deck can be compromised and can become too hazardous to use.

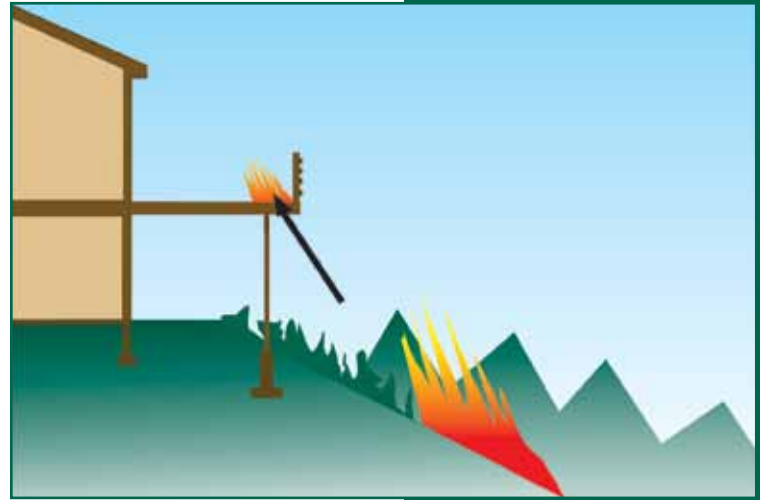

Figure 4-12: Conventional decks can easily ignite during a wildfire

## Isolate the deck from wildfire with a patio and a wall

In low and moderate fire areas, it may be sufficient to isolate the deck from the fuels and fire by building a noncombustible patio and wall below it. The patio will ensure that no combustible materials are below the deck. The wall will act as a shield, deflecting both the radiant and convective energy of the fire.



Figure 4-13: Deck with a patio and a wall below

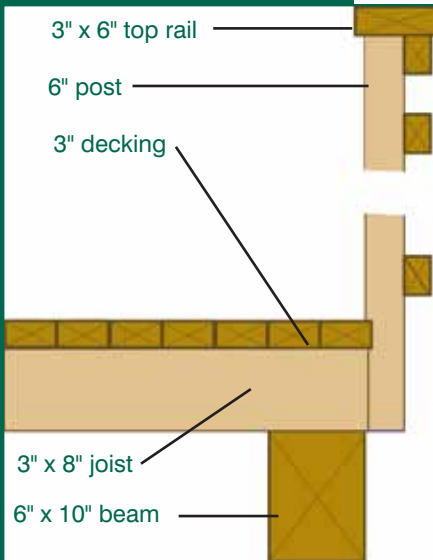

### Heavy timber construction

Like log construction, heavy timber is combustible but so thick that it burns very slowly.

Minimum thickness for a heavy timber deck is 6 inches for the posts and structural members and 3 inches for the decking and rails. This type of construction can be used with a patio below for additional protection.

Figure 4-14: Heavy timber deck

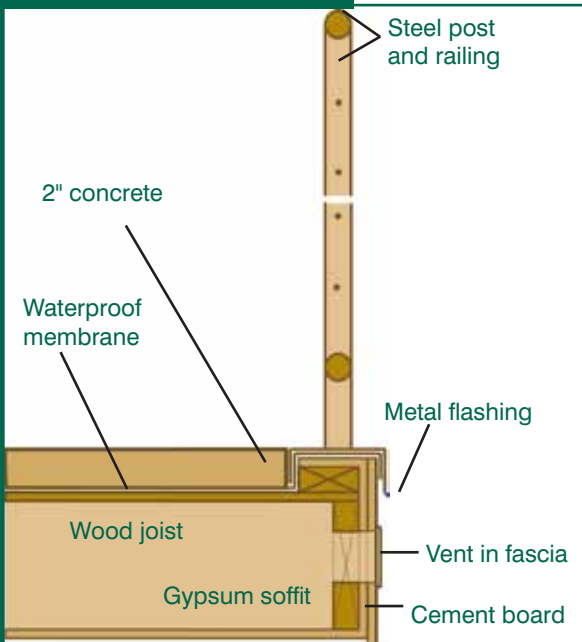

### Fire-resistive deck construction

In the highest fire hazard areas, consider noncombustible surfaces, fire-retardant-treated wood and fire-resistive building materials for a deck. Wood frame construction is permitted, but the surface should be composed of noncombustible, fire-retardant-treated or one-hour fire-resistive materials.

To build this type of surface, place a waterproof membrane over the top of the deck. This allows the use of fire-resistive soffit materials, which cannot tolerate moisture. The most common materials are cement fiber or metal panels (noncombustible), fire-retardant-treated plywood (ignition resistant) and gypsum sheathing (noncombustible).

Cover the membrane with fire-retardant-treated lumber decking, or use 1 to 2 inches of concrete or stone. This surface is ignition resistant and protects the deck from air-borne embers, but will require that the structure be strengthened to support the additional weight.

Posts and railings can be economically built from steel. Wood posts near the ground can have stone, brick or noncombustible coverings, or be of fire-retardant-treated wood. A popular, but expensive, baluster design is steel wire. Steel pipe, usually 1 to 2 inches in diameter, is economical and easy to work with. Square steel shapes can look like traditional wood railings.

Figure 4-15: Fire-resistive deck construction detail

## Fully enclosed decks

The best design is to convert the deck to a solid form by fully enclosing it, completely eliminating the heat trap. This form also complies with the 2009 *International Wildland-Urban Interface Code*.

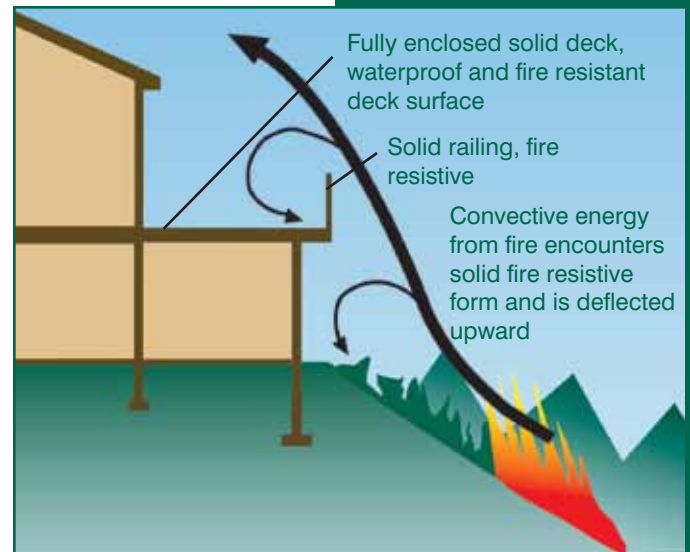

Figure 4-16: Fully enclosed solid deck

## Ignition-resistant construction class

The IWUIC requires that structures constructed, modified or relocated into or within WUI areas meet the requirements of Class 1, Class 2 or Class 3 ignition-resistant construction. The requirements of these ignition-resistant construction classes are based on the fire hazard severity of the site. The greater the fire severity, the greater the fire protection provided by the class. Class 1 provides the most protection in areas of extreme fire hazard; Class 2 provides protection in areas of high fire hazard; and, Class 3 provides additional protection over the traditional construction requirement in areas of moderate fire hazard. The following table is an extract of IWUIC Sections 504, 505 and 506, which define the Class 1, Class 2 and Class 3 requirement, respectively.

# Allowable Construction and Architectural Features for Various Ignition-Resistant Construction Classes

Architectural Feature		Class 1 (Extreme Severity)		Class 2 (High Severity)		Class 3 (Moderate Severity)	
		Class A Roof Assembly		Class B or noncombustible		Class C or noncombustible	
Roof covering	Ignition-resistant material, or 1-hour fire-resistance-rated construction, or 2-inch dimensional lumber, or 1-inch exterior fire-retardant-treated lumber, or ¾-inch exterior fire-retardant-treated plywood	Ignition-resistant material, or 1-hour fire-resistance-rated construction, or 2-inch dimensional lumber, or 1-inch exterior fire-retardant-treated lumber, or ¾-inch exterior fire-retardant-treated plywood	Combustible eaves, facias and soffits shall be enclosed with solid materials with a minimum thickness of ¾ of an inch. No exposed rafter tails are permitted unless constructed of heavy timber.	Class C or noncombustible	No special requirement	Class C or noncombustible	No special requirement
Eaves and soffits	Ignition-resistant material, or 1-hour fire-resistance-rated construction, or 2-inch dimensional lumber, or 1-inch exterior fire-retardant-treated lumber, or ¾-inch exterior fire-retardant-treated plywood	Ignition-resistant material, or 1-hour fire-resistance-rated construction, or 2-inch dimensional lumber, or 1-inch exterior fire-retardant-treated lumber, or ¾-inch exterior fire-retardant-treated plywood	Combustible eaves, facias and soffits shall be enclosed with solid materials with a minimum thickness of ¾ of an inch. No exposed rafter tails are permitted unless constructed of heavy timber.	Class B or noncombustible	No special requirement	Class C or noncombustible	No special requirement
Gutters and downspouts	Ignition-resistant material, or 1-hour fire-resistance-rated construction, or 2-inch dimensional lumber, or 1-inch exterior fire-retardant-treated lumber, or ¾-inch exterior fire-retardant-treated plywood	Ignition-resistant material, or 1-hour fire-resistance-rated construction, or 2-inch dimensional lumber, or 1-inch exterior fire-retardant-treated lumber, or ¾-inch exterior fire-retardant-treated plywood	Combustible eaves, facias and soffits shall be enclosed with solid materials with a minimum thickness of ¾ of an inch. No exposed rafter tails are permitted unless constructed of heavy timber.	Class B or noncombustible	No special requirement	Class C or noncombustible	No special requirement
Exterior walls	Ignition-resistant material, or 1-hour fire-resistance-rated construction, or 2-inch dimensional lumber, or 1-inch exterior fire-retardant-treated lumber, or ¾-inch exterior fire-retardant-treated plywood	Ignition-resistant material, or 1-hour fire-resistance-rated construction, or 2-inch dimensional lumber, or 1-inch exterior fire-retardant-treated lumber, or ¾-inch exterior fire-retardant-treated plywood	Combustible eaves, facias and soffits shall be enclosed with solid materials with a minimum thickness of ¾ of an inch. No exposed rafter tails are permitted unless constructed of heavy timber.	Class B or noncombustible	No special requirement	Class C or noncombustible	No special requirement
Unenclosed underfloor protection	Ignition-resistant material, or 1-hour fire-resistance-rated construction, or 2-inch dimensional lumber, or 1-inch exterior fire-retardant-treated lumber, or ¾-inch exterior fire-retardant-treated plywood	Ignition-resistant material, or 1-hour fire-resistance-rated construction, or 2-inch dimensional lumber, or 1-inch exterior fire-retardant-treated lumber, or ¾-inch exterior fire-retardant-treated plywood	Combustible eaves, facias and soffits shall be enclosed with solid materials with a minimum thickness of ¾ of an inch. No exposed rafter tails are permitted unless constructed of heavy timber.	Class B or noncombustible	No special requirement	Class C or noncombustible	No special requirement
Appendages and projections, such as decks	Ignition-resistant material, or 1-hour fire-resistance-rated construction, or 2-inch dimensional lumber, or 1-inch exterior fire-retardant-treated lumber, or ¾-inch exterior fire-retardant-treated plywood	Ignition-resistant material, or 1-hour fire-resistance-rated construction, or 2-inch dimensional lumber, or 1-inch exterior fire-retardant-treated lumber, or ¾-inch exterior fire-retardant-treated plywood	Combustible eaves, facias and soffits shall be enclosed with solid materials with a minimum thickness of ¾ of an inch. No exposed rafter tails are permitted unless constructed of heavy timber.	Class B or noncombustible	No special requirement	Class C or noncombustible	No special requirement
Exterior glazing	Ignition-resistant building materials Tempered glass, or Multilayered glazed panels, or Glass block, or Fire protection rating of not less than 20 minutes Approved noncombustible construction, or Solid core wood not less than 1 ¾-inch thick, or Fire protection rating of not less than 20 minutes	Ignition-resistant building materials Tempered glass, or Multilayered glazed panels, or Glass block, or Fire protection rating of not less than 20 minutes Approved noncombustible construction, or Solid core wood not less than 1 ¾-inch thick, or Fire protection rating of not less than 20 minutes	Combustible eaves, facias and soffits shall be enclosed with solid materials with a minimum thickness of ¾ of an inch. No exposed rafter tails are permitted unless constructed of heavy timber.	Class B or noncombustible	No special requirement	Class C or noncombustible	No special requirement
Exterior doors	Ignition-resistant building materials Tempered glass, or Multilayered glazed panels, or Glass block, or Fire protection rating of not less than 20 minutes Approved noncombustible construction, or Solid core wood not less than 1 ¾-inch thick, or Fire protection rating of not less than 20 minutes	Ignition-resistant building materials Tempered glass, or Multilayered glazed panels, or Glass block, or Fire protection rating of not less than 20 minutes Approved noncombustible construction, or Solid core wood not less than 1 ¾-inch thick, or Fire protection rating of not less than 20 minutes	Combustible eaves, facias and soffits shall be enclosed with solid materials with a minimum thickness of ¾ of an inch. No exposed rafter tails are permitted unless constructed of heavy timber.	Class B or noncombustible	No special requirement	Class C or noncombustible	No special requirement
Vent location	Ignition-resistant building materials Tempered glass, or Multilayered glazed panels, or Glass block, or Fire protection rating of not less than 20 minutes Approved noncombustible construction, or Solid core wood not less than 1 ¾-inch thick, or Fire protection rating of not less than 20 minutes	Ignition-resistant building materials Tempered glass, or Multilayered glazed panels, or Glass block, or Fire protection rating of not less than 20 minutes Approved noncombustible construction, or Solid core wood not less than 1 ¾-inch thick, or Fire protection rating of not less than 20 minutes	Combustible eaves, facias and soffits shall be enclosed with solid materials with a minimum thickness of ¾ of an inch. No exposed rafter tails are permitted unless constructed of heavy timber.	Class B or noncombustible	No special requirement	Class C or noncombustible	No special requirement

Figure 4-17 \* Not all jurisdictions follow these fire-severity classifications. Consult your local building department, fire department or county planning department for local fire hazard classifications.

\*\* For statewide fire hazard ratings, see the [Colorado Statewide Forest Resource Assessment & Strategy \(Action Plan\)](#).

## 5. Building Materials and Components

When discussing building materials and components, we make frequent references to types of construction, noncombustible materials and various classes and ratings. Flame-spread classes, roofing classes and hourly ratings are confusing terms and sometimes are misused. The first is based on the Society for Testing and Materials' ASTM E-84/UL 723 "Test for Surface Burning Characteristics of Building Materials," the second is based on ASTM E-108/UL 790, "Test for Fire Performance of Roofing Materials," and the third is based on ASTM E-119, "Fire Tests of Building Materials."

### Noncombustible

As applied to building materials, noncombustible means a material that, in the form in which it is used, is one of the following:

1. Material of which no part will ignite and burn when subjected to fire. Any material conforming to ASTM E-136 "Standard Test Method for Behavior of Materials in a Vertical Tube Furnace at 750°C" is considered noncombustible. Materials such as concrete, steel and brick masonry generally are considered noncombustible.
2. Material that has a structural base of noncombustible material, as defined in Item 1 above, with a surfacing material not over 1/8-inch (3.2 mm) thick, and a flame spread index of 50 or less. The paper face on most gypsum wallboard has a flame-spread index of 15 and is considered noncombustible.

If a building material does not fall into either of the above categories, it is assumed to be combustible.

### Flame-spread classification of building materials

The Uniform Building Code UBC uses the I-II-III designation, and the International Building Code (IBC) uses A-B-C. The flame-spread categories are as follows, per ASTM E-84/UL 723:

**Class A or I:** Flame-spread index of 25 or less (Fire-Retardant-Treated Wood or FRTW)

**Class B or II:** Flame spread index of 26 to 75 (some untreated lumber)

**Class C or III:** Flame spread index of 76 to 200 (most untreated lumber and plywood)

### Class A-B-C roof coverings

Class A, B or C roofing systems sometimes are confused with the Class A-B-C/I-II-III flame-spread categories as referenced above. The tendency is to assume that Class A roof systems have a Class A flame spread, and so on, but there is no correlation.

The ASTM E-108/UL 790 roof-coverings test does not produce a flame-spread rating. It is a pass-fail test under which a product either passes the criteria as a Class A, B or C roof covering system or it doesn't. It is an entirely different test from ASTM E-84/UL 723, and it includes weathering per the ASTM D-2898 "Standard Rain Test." The highest fire classification is Class A. Note that a Class C roof system is considered fire resistant, while a Class C (or III) building material (as above) is not. Non-classified roof systems have no fire rating.



## Hourly fire-resistance ratings

Hourly ratings are a function of the assembly being used (wall, floor, door, ceiling, roof, etc.) and generally require use of a noncombustible membrane (e.g. gypsum, masonry). ASTM E-119 “Fire Tests of Building Construction Materials,” is the test used to determine the hourly rating of an assembly. It exposes an assembly to heat and flame on one side and tests for heat transmission, burn-through, structural integrity and ability to withstand a hose stream from a fire hose.

Because of the potential for radiant heat exposure from one structure to another, either on adjoining sites or on the same site, the IBC regulates the construction of exterior walls for fire resistance. Where exterior walls have a fire-separation distance of more than 5 feet, IBC Section 705.5 allows the fire-resistance rating to be determined based only on interior fire exposure. This recognizes the reduced risk that is due to the setback from the lot line. For fire separation distances greater than 5 feet, the hazard is considered to be predominately from inside the structure. Thus, fire-resistance-rated construction whose tests are limited to interior fire exposure is considered sufficient evidence of fire resistance under these circumstances. However, at a distance of 5 feet or less, there is additional hazard of direct fire exposure from a structure on the adjacent lot and the possibility that it may lead to self-ignition at the exterior face of the exposed structure. Therefore, exterior walls located very close to any lot line must be rated for exposure to fire from both sides. The listings of various fire-resistance-rated exterior walls will indicate if they were only tested for exposure from the inside, usually by a designation of “FIRE SIDE” or similar terminology. Where so listed, their use is limited to those applications where the wall need only be rated from the interior side. For application in the WUI, the “FIRE SIDE” of the wall system must be the exterior wall surface.

The difference between a non-combustible material and a rated material or assembly is the surface resistance to ignition versus the protection afforded the structure behind it. A good example of a non-combustible material is metal roofing and siding. Metal is non-combustible, but an excellent conductor of heat. If the fire remains present long enough, the heat will be conducted through the metal and ignite the material behind it. An example of a fire-rated assembly is wood siding applied over 5/8 inch gypsum sheathing. This assembly is rated as one hour. The surface can ignite, but the structure is protected from the fire for one hour. **The importance is the difference between intensity of fire and duration of fire, as described in the fire behavior section (Section 2).**

Most ratings are for commercial structures in urban settings. That is why the IWUIC references the IBC, which is used to build both commercial and residential structures, rather than the IRC, which is used for single family and multi-family homes with up to four units.

The IBC allows both prescriptive and performance-based fire-resistant designs, although its current emphasis is clearly on the former. Section 720 of the code explicitly lists several detailed, prescriptive fire-resistant designs. However, Section 703.3 also allows the designer to choose from other alternative methods for design as long as they meet the fire exposure and criteria specified in the American Society for Testing and Materials (ASTM) fire test standard ASTM E-119.

### **IBC 703.3 Alternative methods for determining fire resistance:**

1. Fire-resistant designs documented in recognized sources.
2. Prescriptive designs of fire resistance-rated building elements, components or assemblies, as prescribed in Section 720.
3. Calculations in accordance with Section 721.
4. Engineering analysis based on a comparison of building element, component or assemblies designs having fire-resistance ratings, as determined by the test procedures set forth in ASTM E119 or UL 263.
5. Alternative protection methods, as allowed by Section 104.11.

Fire-resistant construction assemblies (walls, floors, roofs) and elements (beams, columns), that perform satisfactorily in standard fire-resistance tests, are documented in building codes, standards, test reports and special directories of testing laboratories. Over the years, a considerable amount of accumulated test data allowed the standardization of many fire-resistant designs involving generic (non-proprietary) materials, such as wood, steel, concrete, masonry, clay tile, “Type X” gypsum wallboard and various plasters. These generalized designs and methods are documented in IBC sections 720 and 721, with detailed explanatory figures, tables, formulas and charts. Fire-resistant designs that incorporate proprietary (pertaining to specific manufacturers and/or patented) materials are documented by test laboratories in reports and special directories of both test laboratories and trade associations. The major sources of documented construction designs rated for fire resistance are described below.

Underwriters Laboratories Inc. (UL) conducts tests of various building components and fire protection materials. The assemblies are tested under recognized testing procedures, including ASTM E119 and ANSI/UL 263, all of which are essentially the same. When the assembly complies with the acceptance criteria of the fire-test standard, a detailed report is provided, including its description and performance in the test, pertinent details and specifications of materials used. A summary of the important features is produced and given a UL designation, which is then added to the UL directory.

To facilitate the design process, numerous associations publish wall-design configurations that meet various fire criteria. Examples of these publications are Fire Rated Wood Floor and Wall Assemblies (DCA-3), published by the American Wood Council; Fire Rated Systems Design/Construction Guide (W305), published by APA-The Engineered Wood Association; and Fire Resistance Design Manual (GA-600), published by the Gypsum Association.

## **Heavy timber and log wall construction**

Heavy timber is another type of wood construction. Experience and fire tests have shown that the tendency of a wood member to ignite in a fire is affected by its cross-sectional dimensions. During a fire, large-size wood members form a protective coating of char that insulates the inner portion of the member from the fire. This type of wood construction often is referred to as slow burning.

Different minimum dimensions apply to different types of wood members, and the minimum cross-sectional dimension required in order to qualify for the heavy-timber fire rating is set forth in IBC Section 602.4. The following is a condensed version of building code sections, which is provided as a guide. Consult the IBC or your local building or fire departments to determine complete requirements.

**602.4.1 Columns.** Wood columns shall be not be less than 8 inches nominal in any dimension where supporting floor loads and not less than 6 inches nominal in width and not less than 8 inches nominal in depth where supporting roof and ceiling loads only.

**602.4.2 Floor framing.** Wood beams and girders shall be not less than 6 inches nominal in width and not less than 10 inches nominal in depth.

**602.4.3 Roof framing.** Framed or glued-laminated arches for roof construction, framed timber trusses and other roof framing, which do not support floor loads, shall have members not less than 4 inches nominal in width and not less than 6 inches nominal in depth.

**602.4.4 Floors.** Floors shall be without concealed spaces. Wood floors shall be of sawn or glued-laminated planks, splined or tongue-and-groove, of not less than 3 inches nominal in thickness. Floors shall not extend closer than 0.5 inch to walls. This space shall be covered by a molding fastened to the wall and so arranged that it will not obstruct the swelling or shrinkage movements of the floor.

**602.4.5 Roofs.** Roofs shall be without concealed spaces and wood roof decks shall be of sawn or glued-laminated, splined or tongue-and-groove plank, not less than 2 inches nominal in thickness, 1 1/8 inch thick plywood, or of planks not less than 3 inches nominal in width, set on edge close together and laid as required for floors. Other types of decking shall be permitted to be used if providing equivalent fire resistance and structural properties.

## Fire-retardant-treated wood

Certain ingredients, when added to the wood, can insulate its surfaces so that its temperature remains below the kindling temperature for an extended period of time, no matter how hot the heat source might become. Among the ingredients used for this purpose are the acid salts of sulfates and phosphates, borates and boric acid.

All fire-retardant treatments are water-soluble, so water is used as the vehicle for carrying the treatments into the wood. The only effective method of application is the pressure treatment process. After pressure impregnation, most of the moisture is removed until the treated wood has a moisture content of no more than 19 percent for lumber and 15 percent for plywood.

Fire-retardant treatments do not necessarily prevent wood from being destroyed by fire, but they are the necessary ingredient that, when added to wood, slow decomposition to such an extent that the wood structurally outperforms most other building materials during actual fire conditions.

When temperatures reach a point slightly below the kindling point, the chemicals react with each other. Nonflammable gases and water vapor are formed and released at a slow, persistent rate that envelops the wood fibers, insulating them from temperatures that cause the wood to decompose. The inflammable gases and tars are reduced and an insulating char forms on the surface of the wood, further slowing the process of decomposition. Structural integrity of the wood is preserved for a longer time with the reduced rate of decomposition, and smoke and toxic fumes are greatly reduced. When the heat source is removed, the treated wood ceases to decompose and fire spread is eliminated.

In Section 2303.2, the IBC defines fire-retardant-treated wood as

*“any wood product that, when impregnated with chemicals by a pressure process or other means during manufacture, shall have, when tested in accordance with ASTM E 84 or UL 723, a listed flame spread index of 25 or less and show no evidence of significant*

*progressive combustion when the test is continued for an additional 20-minute period. In addition, the flame front shall not progress more than 10.5 feet (3200 mm) beyond the centerline of the burners at any time during the test.”*

This is far more severe than the 10-minute ASTM E-84 test used for the flame-spread classification of building materials.

Flame-spread classification per ASTM E-84, 30-minute duration, has no relation to a 30-minute rating or any other hourly rating (which must be determined by ASTM E-119). ASTM E-119 is not a required test for FRTW, therefore FRTW has no different hourly rating than untreated wood. The advantage of FRTW over untreated wood and other combustible materials is the fact that it doesn't ignite or contribute to flame spread.

The IWUIC and IBC require FRTW to be properly labeled. Code-compliant stamps must contain the information in Figure 5-1. Product coloration is not a substitute for a building-code approved, third-party inspection agency label.



Figure 5-1: Courtesy of Western Wood Preservers Institute

## Ignition-resistant building material

Ignition-resistant building materials are those that sufficiently resist ignition or sustained flaming combustion under worst-case weather and fuel conditions and with exposure to burning embers and small flames. Ignition-resistant building materials shall comply with any one of the following:

1. Extended ASTM E 84 testing. Materials that, when tested in accordance with the procedures set forth in ASTM E 84 or UL 723, for a test period of 30 minutes, comply with the following:
  - 1.1 Flame spread. Material shall exhibit a flame-spread index not exceeding 25 and shall show no evidence of progressive combustion following the extended 30-minute test.
  - 1.2 Flame front. Material shall exhibit a flame front that does not progress more than 10 1/2 feet (3200 mm) beyond the centerline of the burner at any time during the extended 30-minute test.
  - 1.3 Weathering. Ignition-resistant building materials shall maintain their performance in accordance with this section under conditions of use. Materials shall meet the performance requirements for weathering (including exposure to temperature, moisture and ultraviolet radiation) contained in the following standards, as applicable to the materials and conditions of use:

- 1.3.1 Method A “Test Method for Accelerated Weathering of Fire-Retardant-Treated Wood for Fire Testing” in ASTM D 2898, for fire-retardant-treated wood, wood-plastic composite and plastic lumber materials.
- 1.3.2 ASTM D 7032 for wood-plastic composite materials.
- 1.3.3 ASTM D 6662 for plastic lumber materials.

Identification. All materials shall bear identification showing the fire-test results.

- 2. Noncombustible material.
- 3. Fire-retardant-treated wood identified for exterior use.
- 4. Fire-retardant-treated wood roof coverings. Roof assemblies containing fire-retardant-treated wood shingles and shakes that comply with the requirements of Section 1505.6 of the *International Building Code* and classified as Class A roof assemblies, as required in Section 1505.2 of the *International Building Code*.

## Roofing

### Noncombustible roof coverings

The following are noncombustible roof coverings:

- cement shingles or sheets
- exposed concrete slab roof
- ferrous or copper shingles or sheets
- slate shingles
- clay or concrete roofing tile
- approved roof covering of noncombustible material

Roofing is one of the most important ways to protect a structure from wildfire. As shown earlier, when wildfires become more intense, the lofted embers become a significant cause of the fire spread. Because most roofing has a rough surface and numerous cracks, it can trap wind-blown embers. In many major WUI fires, burning roofs have been observed on structures thousands of feet from the fire.



Figure 5-2: Wood shakes

### Wood shakes and shingles

Simply put, untreated wood shakes and shingles are almost like kindling. They are thin, 1/2- to 1-inch thick, with a very rough surface and many cracks. When an untreated wood roof burns, it also lofts burning embers, contributing to fire spread.

Cedar shakes and shingles can be modified by pressure impregnation with fire-retardants, which changes their classification to either B or C. Fire-retardant-treated cedar shakes and shingles installed over a gypsum underlayment have a Class A assembly rating.



Figure 5-2: Reinforced asphalt shingles

### Asphalt shingles

Conventional mineral reinforced asphalt shingles usually have a Class C rating.

Mineral-reinforced shingles gradually have been replaced by fiberglass-reinforced asphalt shingles. These have a Class A rating. They are available in many colors and textures and can even imitate wood or slate shingles.

## Metal

Metal roofing in many colors is available in sheet form, and usually has standing seams or ribs. The most common metal roof is galvanized steel with factory-applied paint.

Metal roofing also is available in patterns that imitate wood and slate shingles. This product is made by stamping a texture and shape on the metal and then applying the appropriate color. This imitation is so good that at a distance of 100 feet or more it is difficult to tell the difference between it and the material it is imitating.

While metal roofing is noncombustible, it requires a gypsum underlayment in order to have a Class A assembly rating.

In addition to galvanized steel with paint, metal roofing also is available in aluminum with paint, stainless steel and copper. These tend to be more expensive, but may last longer.



Figure 5-4: Metal roofing

## Fiber-cement shingles

These shingles are made of cement and fiberglass, or cement and wood. Like the metal shingle, they are made to imitate a wood shingle's texture, shape and color. The cement in these products is altered with polymers to make it less brittle. These products may be noncombustible and may require an underlayment for a Class A assembly rating.

## Membrane roofs

These materials include both rubber and hot-applied, bituminous-saturated mineral felt for flat roofs. They are marginally combustible, but most often are used with other covering systems such as concrete. They can be applied over a gypsum underlayment for a Class A assembly rating.

## Concrete shingles and tile, slate shingles and clay tile

These products are noncombustible. They are 1-inch thick, heavy (10 pounds per square foot or more) and Class A rated. Concrete shingles often are manufactured to look like wood shingles.



Figure 5-5: Concrete tiles

## Exterior walls: siding

The exterior walls of a structure are most affected by radiant energy from the fire and, if defensible space is not adequate, by direct impingement of the fire.

## Wood panels and boards

Wood panels and boards are the most common and economical forms of siding, but they are readily combustible. This siding usually is not very thick (1/2-inch to 3/4-inch) and will burn through to the structure behind it in less than 10 minutes. A one-hour fire-resistance rating can be achieved by adding 5/8-inch Type X gypsum sheathing behind the siding.

Fire-retardant-treated lumber and plywood siding is another option. These products are traditional wood-siding materials that have been pressure impregnated with fire retardants and meet the definition of ignition-resistant materials. They can be used in all fire hazard severity zones.



Figure 5-6: Wood siding

## Fiber cement panels, boards and shingles

While these products may be noncombustible, they may not have a fire-resistance rating and may need gypsum sheathing to achieve a one-hour rating. These materials are virtually permanent on a vertical surface and may need to be painted; stain can even be used on some with satisfactory results. These products are available with textures molded to imitate wood grain.

## Metal

Like their counterparts in roofing, metal siding is available in either flat sheets with seams or in stamped patterns intended to imitate wood boards or shingles. They are noncombustible, but like other metal products, they need gypsum sheathing to achieve a one-hour rating.

## Stucco

Real stucco, as base material, is  $\frac{3}{4}$ -inch to 1-inch thick cement and gypsum. The stucco is applied in two or three coats with metal mesh reinforcement. It is both a non-combustible and one-hour rated material, which makes it a very good material for high-hazard areas.

## Synthetic stucco

Synthetic stucco also is referred to as EIFS (exterior insulating finish system). It consists of a  $\frac{1}{8}$ -inch thick acrylic cement finish on fiberglass mesh. This is applied to the top 1 to 2 inches of expanded polystyrene insulation. The surface may be noncombustible and has no rating by itself. During a fire, it can delay ignition of the structure because it melts and falls away. It can, like other products, obtain a one-hour rating with gypsum sheathing.



Figure 5-7: Log wall construction

## Log wall construction

Log wall construction has exterior walls constructed of solid wood members where the smallest horizontal dimension of each member is at least 6 inches. Although the logs are combustible, the low surface-to-volume ratio of the logs causes them to burn very slowly.

Log siding is not an acceptable substitute for log wall construction, as it is not as thick as actual log wall construction. However, log siding can achieve a one-hour fire resistance rating by adding  $\frac{5}{8}$ -inch Type X gypsum sheathing behind the siding.

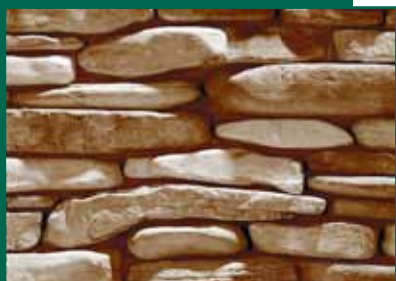

Figure 5-8: Concrete synthetic stone

## Concrete synthetic stone

Concrete synthetic stone is cast concrete with integral color forming the texture and shape of the stone being imitated. The stones are modular in shape with consistent dimensions and flat backs. This synthetic stone is noncombustible and can have a fire resistance rating.

## Brick, stone and block

These materials are inherently noncombustible and can have a fire-resistance rating.



Figure 5-9: Brick wall

## Windows and Glass

Windows are one of the weakest parts of a structure with regard to fire. They usually fail before the structure ignites, providing a direct path for the fire to reach the structure interior.

### Glass failure

Glass provides only a partial barrier to fire and only for a short time as it fractures in the presence of heat. In the case of a wildfire, this will happen in about five minutes. Glass deflects most of the convective energy, but not the radiant energy of the fire.

Convective energy contains hot air and gasses. Approximately 70 percent of the heat is deflected by window glass; roughly 20 percent is absorbed; and 10 percent is transmitted to the interior of the structure.

Radiant energy from a fire is infrared light energy, like the energy we experience from the sun. Sixty percent of the radiant energy from a fire is transmitted through the glass to the interior of the structure; approximately 20 percent is reflected; and the other 20 percent is absorbed by the window glass.

Both radiant and convective energy heats the glass, but the perimeter of the glass is covered and protected by a sash. As a result, differential heating and stressing of the glass occurs, which causes it to crack.

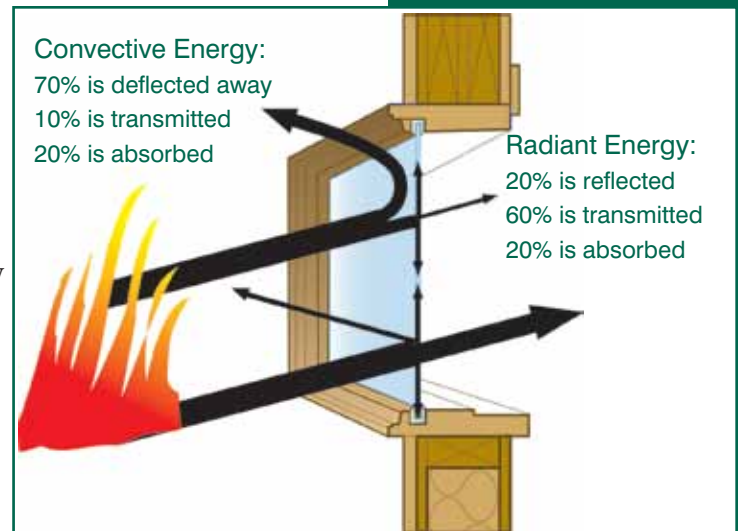

Figure 5-10: Energy transmission, conventional glass

### Large and small windows

Even if the glass does fracture, the hot gasses (convective energy) from the fire and the fire itself cannot enter the structure if the glass stays in place. Only the radiant energy heat can pass through the glass. Eventually, even with the glass in place, combustible materials behind the window may ignite. (See Low E glass).

Small windows, less than 2 feet wide or tall on a side, will keep fractured glass in place. The size of glass held in place by the sash is relatively small and light weight.

Large windows (more than 2 feet wide or tall on a side) cannot keep the fractured glass in place. The size and weight of glass in relationship to the length of sash is too great.

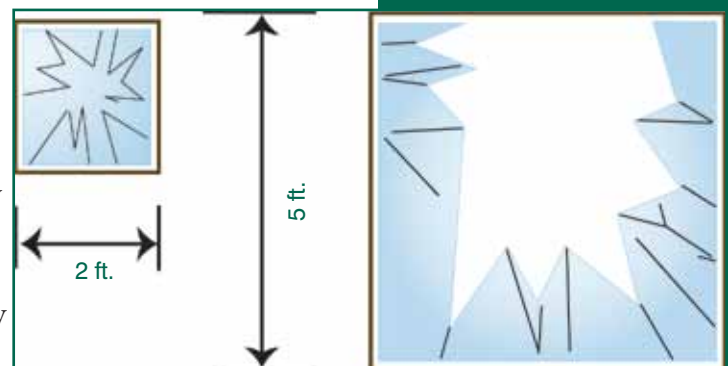

Figure 5-11: Small and large windows





Figure 5-12: Thermopane window

## Thermopane or double-glazed windows

Most of today's energy codes require glass to be double-glazed or Thermopane. During a fire event, double-glazed windows last approximately twice as long as a single pane, or about 10 minutes.

The same processes of convective and radiant energy affect the front pane of glass. As long as the front pane is in place, the second pane is partially protected. When the front pane fails and falls away, the process continues until the second pane fails and falls away.

As shown earlier in the fire behavior section (Section 2), the duration of a fire in an area is dependent on slope and fuels; which, in the case of a grass fire, can be as short as 5 minutes.

If the duration of the fire is any longer than 10 minutes due to preheating or significant fuel around the structure, additional protection is necessary to prevent glass failure and fire from entering the structure.

## Tempered glass

Tempered glass is resistant to high impact and high heat, which means it will remain in place and intact throughout a wildfire event. Building codes require tempered glass to be used in patio doors and all areas subject to human impact. Tempered glass also is used in front of fireplaces.

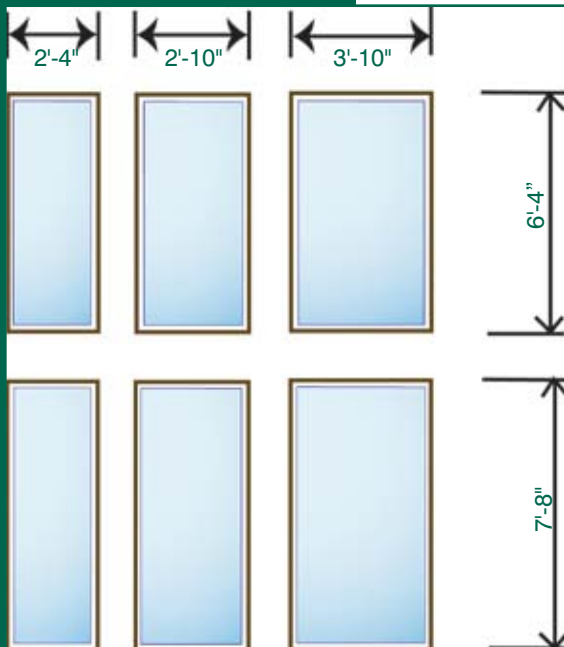

Figure 5-12: Patio door replacement unit sizes

Tempered glass typically costs 50-percent more than regular glass. However, patio door replacement units are mass-produced and stocked by virtually every glass business. As a result, they are economical and less expensive than conventional glass. They come in six sizes, as shown in Figure 5-12, and typically can be used as a picture window unit, or combined to make a window wall or solar structure.

Using patio door replacement units provides tempered glass at a very economical price.

A few brands of windows are marketed as replacement windows in existing mid-rise urban structures where the use of tempered glass is required. As a result, the additional cost for these brands of tempered glass is only 25 percent more than standard glass. Your local window supplier can suggest appropriate manufacturers.

## Glass block

Glass block is the most fire-resistive glass available. It has the highest available rating of 90 minutes.

Glass block may be a good choice when only daytime lighting is needed, a view is not a factor and the window is oriented toward a very high fire hazard.



Figure 5-14: Glass block

## Doors

### Wood doors

Residential structures typically use wood doors with glass inserts. The same fire issues related to window glass apply to glass in doors. An unrated wood door typically is 1 1/2 to 2 inches thick, and can readily ignite and burn through in only 10 minutes, which is much faster than the rest of the structure.

Wood doors are available with a 20-minute rating. Solid-core wood doors a minimum of 1 1/2-inches thick also are acceptable.

### Metal doors, steel and aluminum

Metal doors are non-combustible and available with 20-minute, 45-minute and 90-minute ratings. Glass sizes are restricted in these doors. The surfaces are available with embossing to simulate wood grain and raised panel designs.

Just as with energy conservation, a good fire-resistant door requires adequate weather stripping to prevent hot gasses or burning embers from entering the structure.

## 6. Summary

A major wildfire can be an overwhelming event to experience. It can be huge, blotting out the sun and creating its own winds. It can throw flames and burning embers everywhere. Wildfire is a natural part of our environment that we can either respect or fear. When we modify our homes and the surrounding environment, we can adapt to living in fire-prone areas. Every WUI resident must understand the basic characteristics of wildfire and the risks it presents to their lives and property. The actions we take by building appropriate structures and properly caring for the surrounding environment can significantly reduce wildfire hazards.

A comparison often is made between fire and water. Fire, like water, tries to find a way into our homes. It does not matter how fire-resistant some parts of a structure are if weak points allow a fire to enter. An awareness of how each building component is affected by fire will allow the owner, architect or builder to eliminate those weak points.

## References and Additional Resources

*2009 International Wildland-Urban Interface Code*

International Code Council, Inc.

[www.iccsafe.org/Store/Pages/Product.aspx?id=3850X09](http://www.iccsafe.org/Store/Pages/Product.aspx?id=3850X09)

*NFPA 1144 Standard for Reducing Structure Ignition Hazards from Wildfire*

National Fire Protection Association, (NFPA)

[www.nfpa.org/catalog/product.asp?pid=114413](http://www.nfpa.org/catalog/product.asp?pid=114413)

*2009 International Building Code*

International Code Council, Inc.

[www.iccsafe.org/Pages/default.aspx](http://www.iccsafe.org/Pages/default.aspx)

Fire-Retardant-Treated Lumber and Plywood

Hoover Treated Wood Products

[www.FRTW.com](http://www.FRTW.com)

*The following is a partial list of organizations that can provide more information on the subjects covered in this document.*

### **Colorado State Forest Service**

<http://csfs.colostate.edu/>

<http://csfs.colostate.edu/pages/wildfire.html>

<http://csfs.colostate.edu/pages/wf-publications.html>

### **Fire Adapted Communities**

<http://fireadapted.org/>

**Firewise Communities USA** (National Fire Protection Association)

<http://www.firewise.org/>

**eXtension Wildfire Information Network (eWIN)**

[http://www.extension.org/surviving\\_wildfire](http://www.extension.org/surviving_wildfire)

**Southern Rockies Fire Science Network**

<http://www.frames.gov/partner-sites/srfsn/home/>

**Federal Emergency Management Agency-Wildfire**

<http://www.ready.gov/wildfires>

**Insurance Institute for Business and Home Safety**

<http://www.disastersafety.org/Wildfire>

**USDA Forest Service, Southern Research Station,**

**Centers for Urban and Interface Forestry**

<http://www.humanandnaturalsystems.org/technology/cuif>

**University of Nevada Cooperative Extension, Living with Fire**

<http://www.livingwithfire.info/who-we-are>

## Acronyms

APA	American Plywood Association (now APA-The Engineered Wood Association)
ANSI	American National Standards Institute
ASTM	American Society for Testing and Materials
BOCA	Building Officials and Code Administrators International, Inc
FEMA	Federal Emergency Management Agency
FRTW	Fire-retardant-treated wood
ICBO	International Conference of Building Officials
ICC	International Code Council
IRC	International Residential Code
IWUIC	International Wildland-Urban Interface Code
NFPA	National Fire Protection Association
SBCCI	Southern Building Code Congress International
UBC	Uniform Building Code
UL	Underwriter's Laboratory
WHIMS	Wildfire Hazard Identification and Mitigation System
WUI	Wildland-Urban Interface

