

- PROPERTY LINE
- X - X - EX. FENCE
- X - X - PROPOSED FENCE
- - - PROPERTY SETBACK
- - - OHE EX. OVERHEAD ELECTRIC
- - - UGE EX. UNDERGROUND ELECTRIC
- - - S - S - EX. SANITARY SEWER
- - - PROPOSED BUILDING
- - - EX. BUILDING
- - - PROPOSED FRENCH DRAIN
- - - PROPOSED GRAVEL
- - - PROPOSED CONCRETE

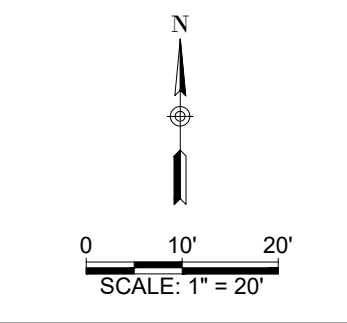

**3 ROCKS**  
**ENGINEERING & SURVEYING**  
 430 MAIN STREET  
 CANON CITY, CO 81212  
 719.430.5333  
 www.3rockengineering.com  
 FOR MUNICIPAL USE:



**YANKO BAKERY**

ISSUED DATES
10/29/2024

PROJECT ENG: NC  
 QA/QC: -  
 DRAWN BY: NEA  
 PRI # 24.150  
 DATE: 10/29/2024

**C1.0** /1

SITE PLAN

60 ORCHARD LANE HOWARD CO, 81223  
 P:\2024\24.150-yanko bakery\p-dwg\cml\yankobakery-sheet1.dwg 10/29/2024 10:24:05 AM KEITH FROUDMAN